

Versione **ACCOPIATA (BASE-GIUNTO)**  
**COUPLED construction (BASEPLATE-COUPLING)**

Esecuzione /R  
 Construction /R

Esecuzione /C Construction /C

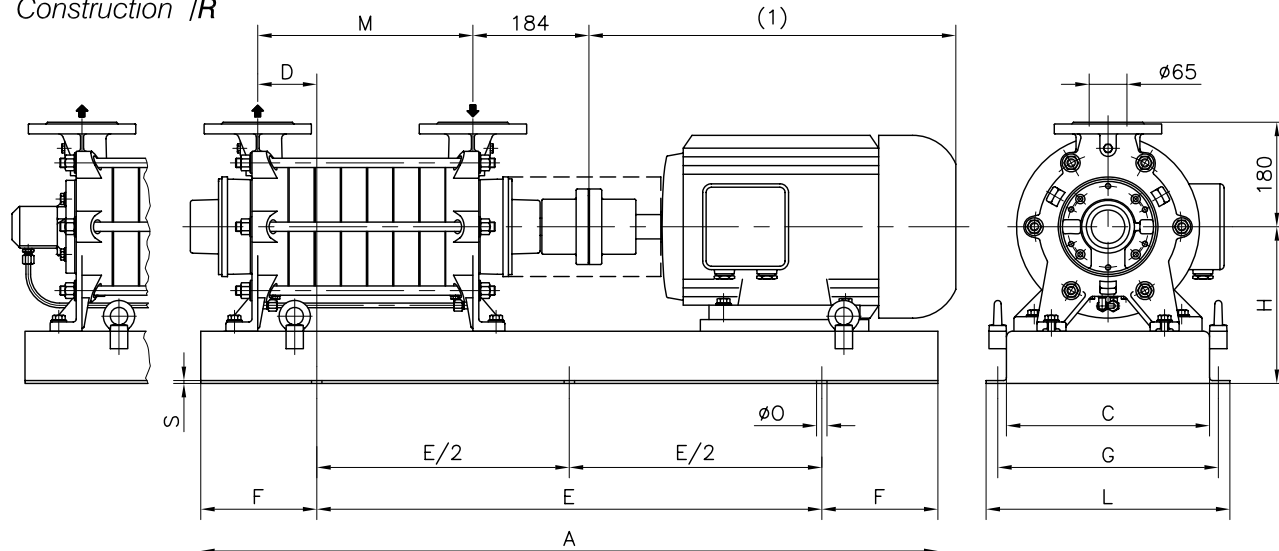

**FLANGE:** Dimensioni secondo UNI 2223-2229 PN40

**FLANGES:** Dimensions to UNI 2223-2229 NP40 standards

POMPA TIPO Pump type	M	MOTORE ELETTRICO Electric motor																				
		132S / 132M				160M / 160L				180M / 180L				200L				225S / 225M				
		N°	D	H	Peso Weight	N°	D	H	Peso Weight	N°	D	H	Peso Weight	N°	D	H	Peso Weight	N°	D	H	Peso Weight	
TBH 651	190	900	75	245	92	903	55	270	118													
TBH 652	280	900	120	245	107	903	100	270	133	907	45	280	150									
TBH 653	370	903	80	270	142	903	145	270	148	907	70	280	165	907	95	300	184	034	0	355	207	
TBH 654	460	903	125	270	157	906	100	280	184	041	130	310	187	041	165	330	199	034	50	355	222	
TBH 655	550	906	120	280	191	906	145	280	199	034	75	310	200	034	100	330	232	034	135	355	237	
TBH 656	640																	034	160	355	252	
TBH 657	730																	034	230	355	267	
TBH 658	820																					

POMPA TIPO Pump type	M	250M				280S / 280M			
		N°	D	H	Peso Weight	N°	D	H	Peso Weight
TBH 651	190								
TBH 652	280								
TBH 653	370								
TBH 654	460								
TBH 655	550	034	165	380	240				
TBH 656	640	042	145	380	280	039	20	415	285
TBH 657	730	039	50	385	295	039	90	415	300
TBH 658	820	039	140	385	300	039	160	415	315

**MOTORI ELETTRICI**  
 Electric Motors

Grandezza Frame size IEC	Giri/min. RPM 1450
	Kw
132S	5,5
132M	7,5
160M	11
160L	15
180M	18,5
180L	22
200L	30
225S	37
225M	45
250M	55
280S	75
280M	90

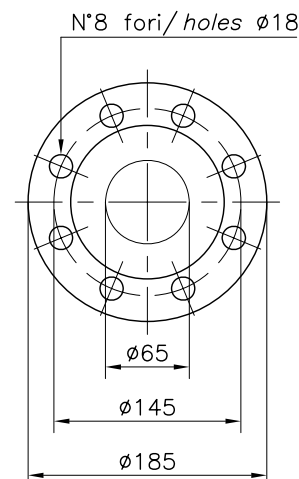

BASAMENTI Base plates									
N°	A	C	E	F	L	G	S	ØO	N° fori holes
900	960	310	600	180	370	340	5	14	4
903	1170	350	770	200	410	380	6	14	4
906	1400	350	950	225	410	380	6	14	4
907	1200	420	900	150	510	470	6	18	4
034	1700	450	1100	300	590	540	7	18	4
039	2150	540	1600	275	680	630	7	18	6
041	1350	420	900	225	560	510	7	18	4
042	1800	500	1400	200	640	590	7	18	6

Disegno schematico. Dimensioni in mm con tolleranze secondo EN 735-1995. Pesì indicativi in Kg, riferiti a pompe in ghisa escluso motore, non impegnativi.  
 Schematic drawing. Dimensions in mm with tolerances to EN 735-1995 standards. Weights in Kgs, referred to pumps in cast iron without motor, not certified.

(1) Dimensioni in funzione della marca del motore installato. (1) Not certified dimensions according to installed motor manufacture.