

DIMENSIONE D'INGOMBRO / Overall dimensions  
 POMPE CENTRIFUGHE AUTOADESCANTI  
 Self-priming centrifugal pumps  
 SERIE / Series  
 TBA 290 - 300 - 310 / 2

**pompetravaini**

CASTANO PRIMO (MILANO)

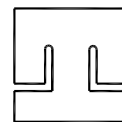

Versione ad ASSE NUDO  
 Esecuzione /R

*BARESHAFT construction*  
 Construction /R

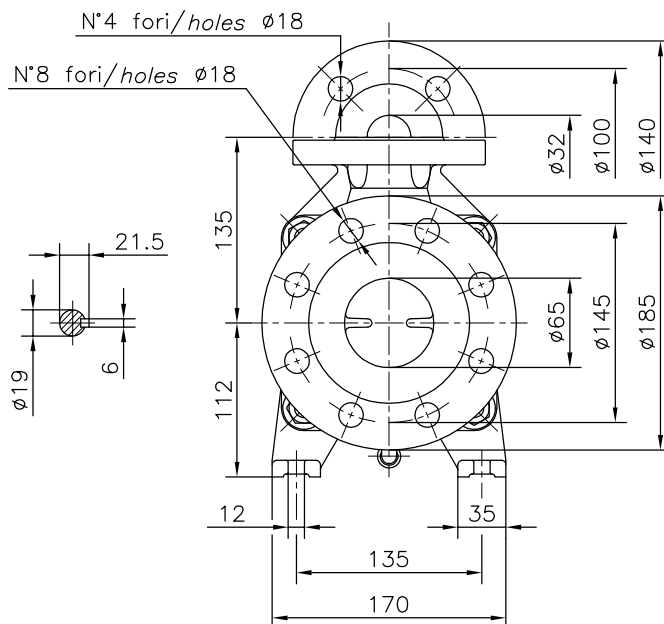
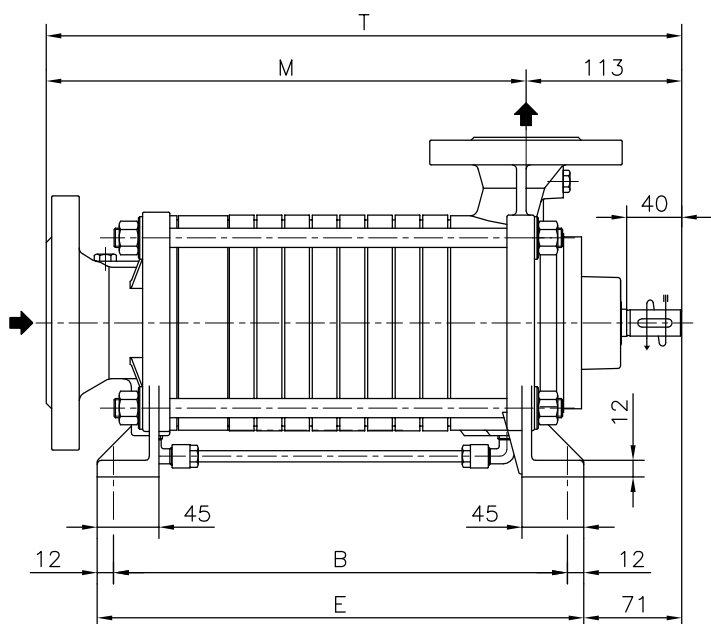

POMPA TIPO <i>Pump type</i>	Versione ad ASSE NUDO			<i>BARESHAFT construction</i>			
	DIMENSIONI <i>Dimensions</i>			/R		/R/T	
	M	B	E	T	Peso <i>Weight</i>	T <sub>1</sub>	Peso <i>Weight</i>
TBA 291 - 301 - 311	228	209	233	341	24	415	29
TBA 292 - 302 - 312	268	249	273	381	27,5	455	32,5
TBA 293 - 303 - 313	308	289	313	421	31	495	36
TBA 294 - 304 - 314	348	329	353	461	34,5	535	39,5
TBA 295 - 305 - 315	388	369	393	501	38	575	43
TBA 296 - 306 - 316	428	409	433	541	41,5	615	46,5
TBA 297 - 307 - 317	468	449	473	581	45	655	50
TBA 298 - 308 - 318	508	489	513	621	48,5	695	53,5

FLANGE:  
 Dimensioni secondo  
 UNI 2223-2229 PN40

FLANGES:  
 Dimensions to  
 UNI 2223-2229 NP40 standards

Disegno schematico. Dimensioni in mm con tolleranze secondo EN 735-1995. Pesi indicativi in Kg, riferiti a pompe in ghisa escluso motore, non impegnativi.

Schematic drawing. Dimensions in mm with tolerances to EN 735-1995 standards. Weights in Kgs, referred to pumps in cast iron without motor, not certified.

Esecuzione /R/T

*Construction /R/T*

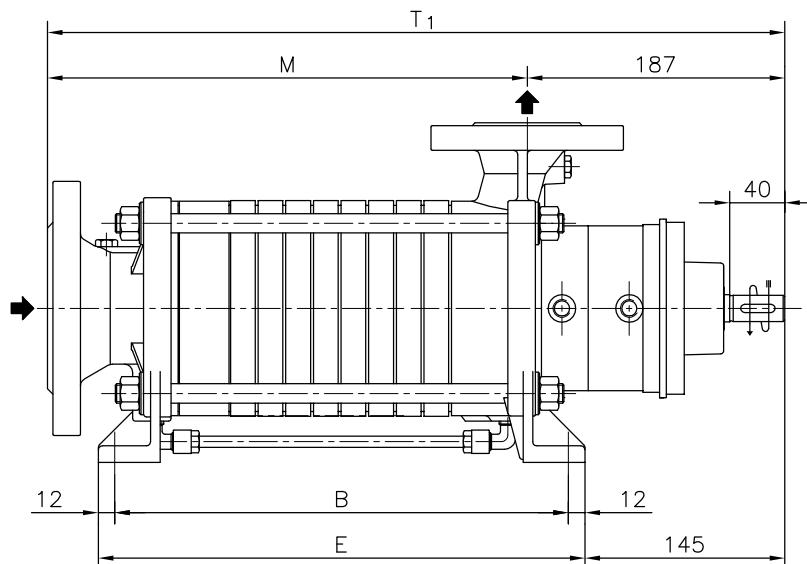

RIF. - Ref.: Z.A./C.T.

SOSTITUISCE - Replaces:

DATA - Date: DICEMBRE 98 - December 98

N°.: 1502÷4.2L1.201.01