

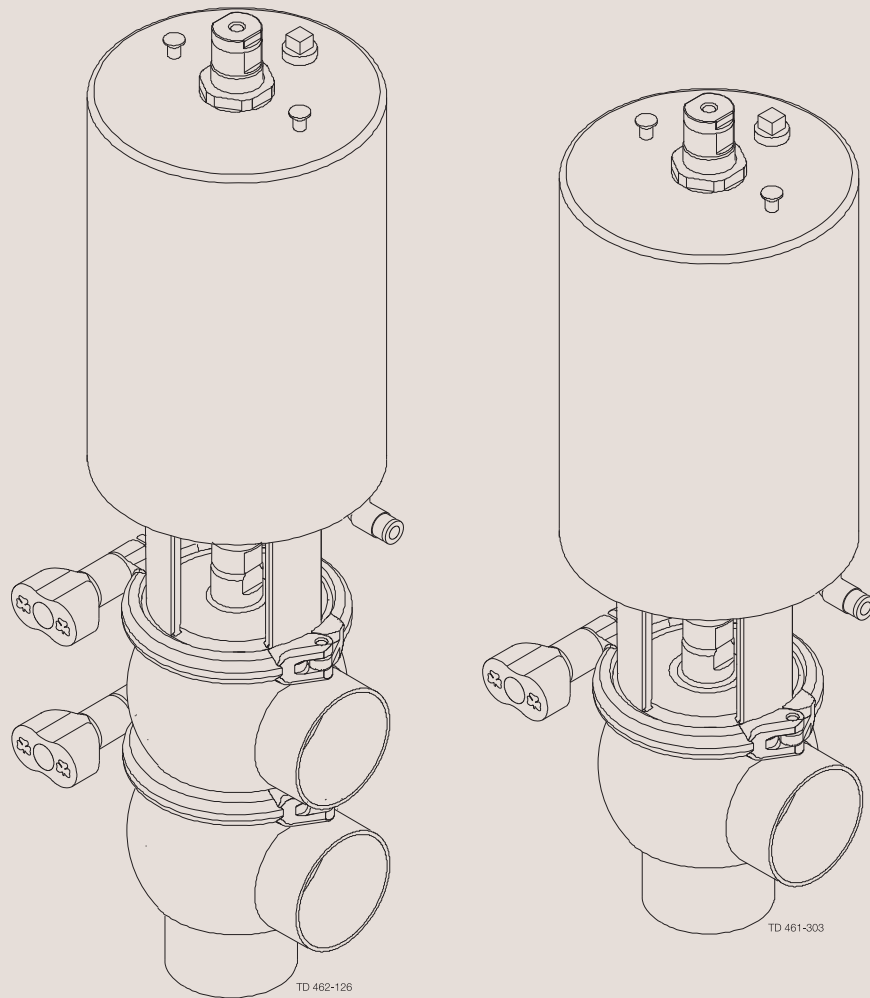

Instruction Manual

Unique 7000 Series Valve - Standard and Reverse Acting



ESE00213-ENUS3 2011-11

Original manual

The information herein is correct at the time of issue but may be subject to change without prior notice

1. EC Declaration of Conformity	4
2. Safety	5
2.1. Important information	5
2.2. Warning signs	5
2.3. Safety precautions	6
3. Installation	8
3.1. Unpacking/delivery	8
3.2. General installation	10
3.3. Welding	11
3.4. Recycling information	12
4. Operation	13
4.1. Operation	13
4.2. Troubleshooting	15
4.3. Recommended cleaning	16
5. Maintenance	18
5.1. General maintenance	18
5.2. Dismantling of valve	20
5.3. Elastomer seat ring replacement	21
5.4. Assembly of valve	22
5.5. Actuator bushing replacement	22
5.6. Dismantling of optional maintainable actuator	22
5.7. Assembly of optional maintainable actuator	22
5.8. Reversing optional maintainable actuator operation	23
6. Technical data	24
6.1. Technical data	24
7. Parts list and Service Kits	25
7.1. Drawing	25
7.2. Unique 7000 TR2 - Shut-off-Valve	26
7.3. Unique 7000 TR2 - Change-over-Valve	28
7.4. Unique 7000 Elastomer plug seal - Shut-off-Valve	30
7.5. Unique 7000 Elastomer plug seal - Change-over-Valve	32

*Unsafe practices and other important information are emphasized in this manual.
Warnings are emphasized by means of special signs.*

2.1 Important information

Always read the manual before using the valve!

WARNING

Indicates that special procedures must be followed to avoid serious personal injury.

CAUTION

Indicates that special procedures must be followed to avoid damage to the valve.

NOTE

Indicates important information to simplify or clarify procedures.

2.2 Warning signs

General warning:



Caustic agents:



2 Safety

All warnings in the manual are summarized on this page.

Pay special attention to the instructions below so that severe personal injury and/or damage to the valve are avoided.

2.3 Safety precautions

Installation:

Always read the technical data thoroughly (See chapter 6 Technical data)

Always release compressed air after use

Never touch the moving parts if the actuator is supplied with compressed air

Never touch the valve or the pipelines when processing hot liquids or when sterilizing

Never dismantle the valve with valve and pipelines under pressure

Never dismantle the valve when it is hot



Operation:

Never dismantle the valve with valve and pipelines under pressure

Never dismantle the valve when it is hot

Always read the technical data thoroughly (See chapter 6 Technical data)

Always release compressed air after use

Never touch the valve or the pipelines when processing hot liquids or when sterilizing

Never touch the moving parts if the actuator is supplied with compressed air

Always rinse well with clean water after the cleaning

Always handle lye and acid with great care



Maintenance:

Always read the technical data thoroughly (See chapter 6 Technical data)

Always release compressed air after use

Never service the valve when it is hot

Never service the valve with valve and pipelines under pressure

Never stick your fingers through the valve ports if the actuator is supplied with compressed air

Never touch the moving parts if the actuator is supplied with compressed air



All warnings in the manual are summarized on this page.

Pay special attention to the instructions below so that severe personal injury and/or damage to the valve are avoided.



WARNING!

When using “support air” on spring side in all the Unique 7000 actuators, the pressure must **NOT** exceed 3 bar (43.5 PSI).

When using Unique 7000 actuators with OD156mm (6 1/7 inch) with support air, **always** use the “steel adapter” (pos. 5). Tighten the “steel adapter” with torque of 30 Nm (23 lbf-ft) and use Loctite 243.

The actuator with OD156mm is mainly used on valves ISO76/DN80 – ISO101/DN100.

The outer actuator diameter = 6 1/7 inch.

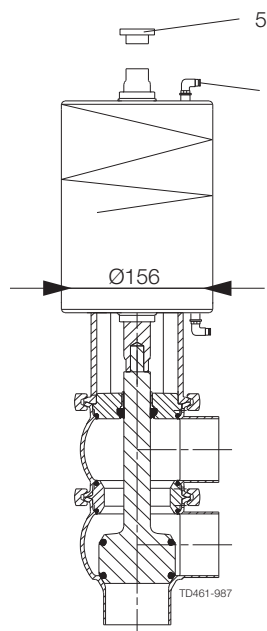

Max. 3 bar (43.5 PSI) “support air” on spring side.

Ø156 (6 1/7 inch.)

3 Installation

The instruction manual is part of the delivery. Study the instructions carefully.

The items refer to parts list and service kits section.

The valve is supplied as separate parts as standard (for welding).

The valve is assembled before delivery, if it is supplied with fittings.

3.1 Unpacking/delivery

Step 1

CAUTION

Alfa Laval cannot be held responsible for incorrect unpacking.

Check the delivery for:

1. Complete valve, shut off valve (RA) or change-over valve (RA) (see steps 2a, 2b, 2c and 2d).
2. Delivery note.
3. Instruction manual.

Step 2

2a

Shut-off valve:

1. Complete actuator.
2. Bonnet (20).
3. Clamp (19).
4. Valve plug (23).
5. Valve body (22).

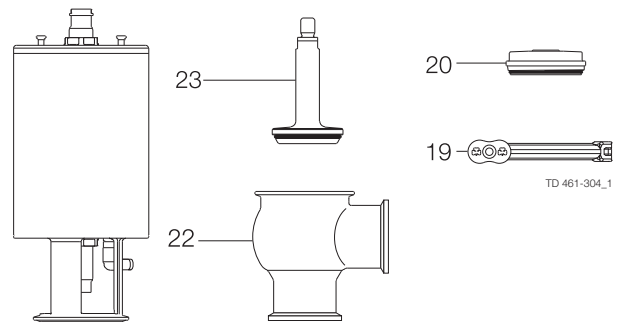

2b

Change-over valve:

1. Complete actuator.
2. Bonnet (20).
3. 2 x clamp (19).
4. Valve plug (27).
5. Lower valve body (22).
6. Valve seat (28).
7. Upper valve body (26).

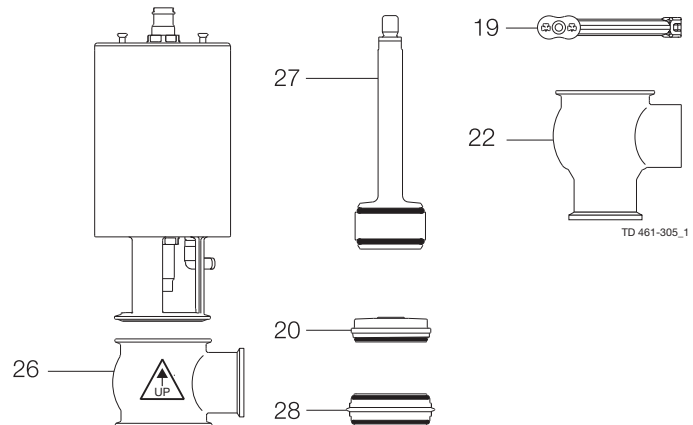

2c

Shut-off valve - Reverse Acting:

1. Complete actuator.
2. Bonnet (20).
3. 3 x clamp (19).
4. Valve plug (23).
5. 2 x upper valve body (26).
6. Valve seat (28).
7. Lower bonnet (33).

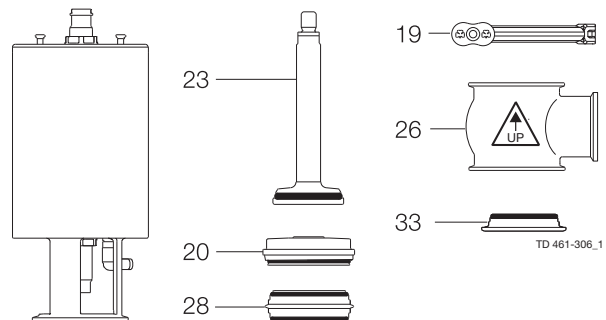

The instruction manual is part of the delivery. Study the instructions carefully.
The items refer to parts list and service kits section.
The valve is supplied as separate parts as standard (for welding).
The valve is assembled before delivery, if it is supplied with fittings.

2d

Change-over valve - Reverse Acting:

1. Complete actuator.
2. Bonnet (20).
3. 4 x clamp (19).
4. Upper valve plug (34).
5. Lower valve plug (35).
6. 3 x upper valve body (26).
7. 2 x valve seat (28).
8. Lower bonnet (33).

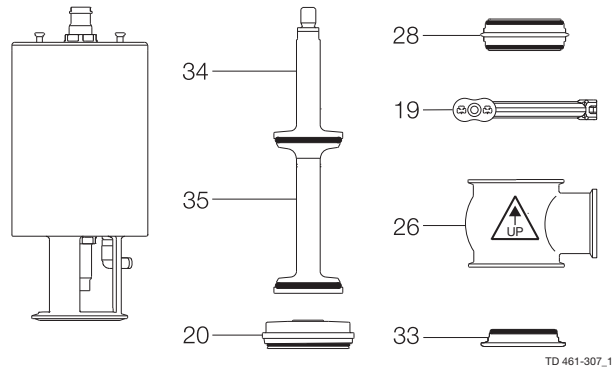

Step 3

Remove possible packing materials from the valve/valve parts.
Inspect the valve/valve parts for visible transport damages.
Avoid damaging the valve/valve parts.

3 Installation

Study the instructions carefully and pay special attention to the warnings!
The valve has welding ends as standard but can also be supplied with fittings.

3.2 General installation

Step 1



Always read the technical data thoroughly.
See chapter 6 Technical data



Always release compressed air after use.

CAUTION

Alfa Laval cannot be held responsible for incorrect installation.

Step 2



Never touch the moving parts if the actuator is supplied with compressed air.

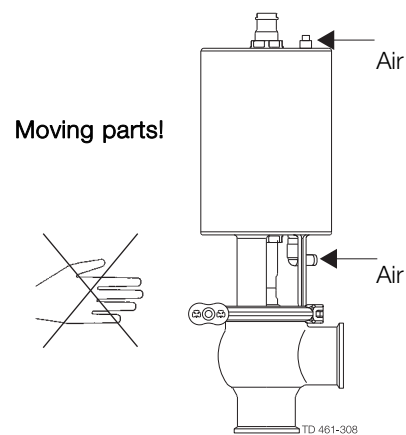

Step 3

It is recommended to install the valve so that the flow is against the closing direction to avoid water hammer.

Shock in the actuator must **never** occur.

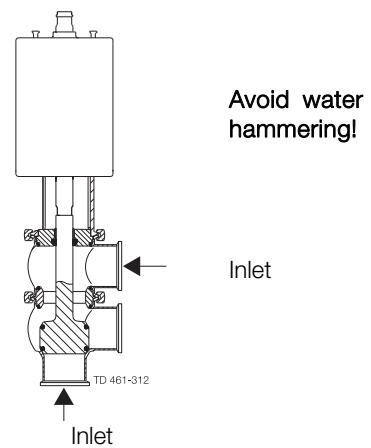

Step 4

Avoid stressing the valve.

Pay special attention to:

- Vibrations.
- Thermal expansion of the pipelines.
- Excessive welding.
- Overloading of the pipelines.

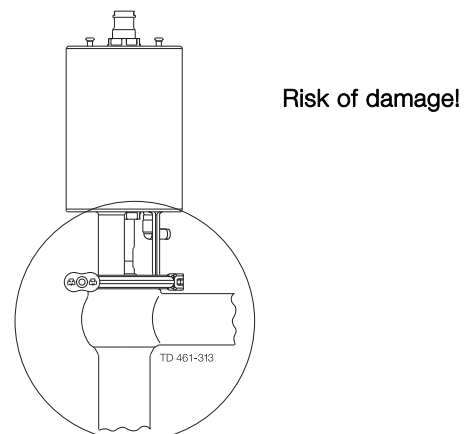

Study the instructions carefully.
 The valve is supplied as separate parts to facilitate the welding.
 The items refer to the parts list and service kits section.
 Check the valve for smooth operation after welding.

3.3 Welding

Step 1

Always install valves with more than one valve body so that the seals between the valve bodies can be replaced. Do not weld more than one valve body into the system.

Valve size	A (inch)	B (inch)
1"	*	24.8
1 1/2"	*	27.6
2"	*	29.5
2 1/2"	*	29.1
3"	*	31.5
4"	*	31.1

* Depending on body combination and piping solution.

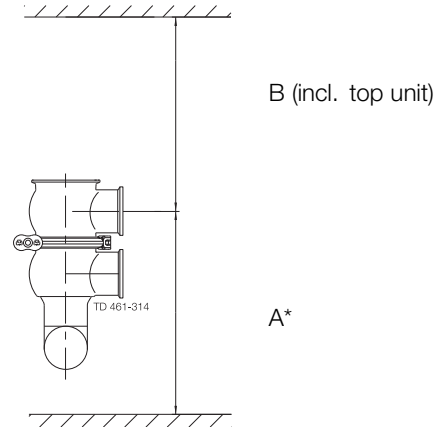

Step 2

Assemble the valve in accordance with the steps on page 22.
Pay special attention to the warnings!

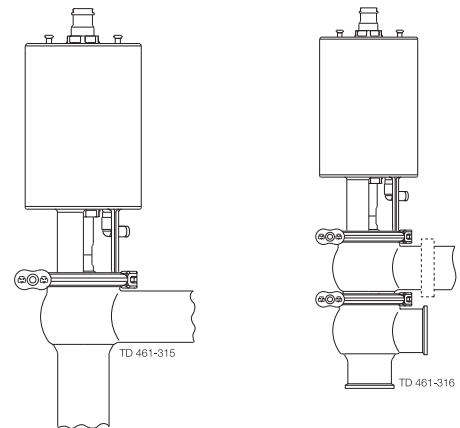

Step 3

Pre-use check:

1. Supply compressed air to the actuator.
2. Open and close the valve several times to ensure that it operates smoothly.

Pay special attention to the warnings!

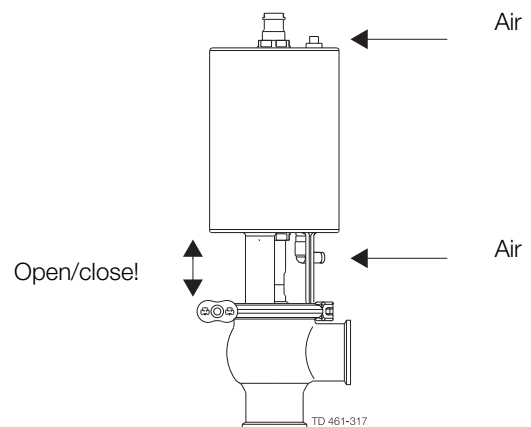

3 Installation

Study the instructions carefully.

The valve is supplied as separate parts to facilitate the welding.

The items refer to the parts list and service kits section.

Check the valve for smooth operation after welding.

3.4 Recycling information

- **Unpacking**

- Packing material consists of wood, plastics, cardboard boxes and in some cases metal straps
- Wood and cardboard boxes can be reused, recycled or used for energy recovery
- Plastics should be recycled or burnt at a licensed waste incineration plant
- Metal straps should be sent for material recycling

- **Maintenance**

- During maintenance oil and wear parts in the machine are replaced
- All metal parts should be sent for material recycling
- Worn out or defective electronic parts should be sent to a licensed handler for material recycling
- Oil and all non metal wear parts must be taken care of in agreement with local regulations

- **Scrapping**

- At end of use, the equipment shall be recycled according to relevant, local regulations. Beside the equipment itself, any hazardous residues from the process liquid must be considered and dealt with in a proper manner. When in doubt, or in the absence of local regulations, please contact the local Alfa Laval sales company
-

Study the instructions carefully and pay special attention to the warnings!
 Ensure that the valve operates smoothly.
 The items refer to the parts list and service kits section.

4.1 Operation

Step 1



Always read the technical data thoroughly.
 See chapter 6 Technical data



Always release compressed air after use.

CAUTION

Alfa Laval cannot be held responsible for incorrect operation.

Step 2



Never touch the valve or the pipelines when processing hot liquids or when sterilizing.

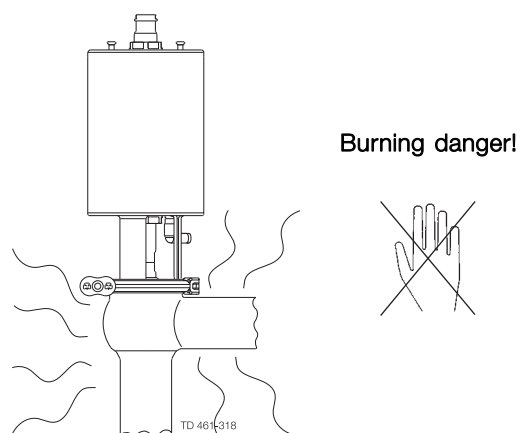

Step 3



Never touch the moving parts if the actuator is supplied with compressed air.

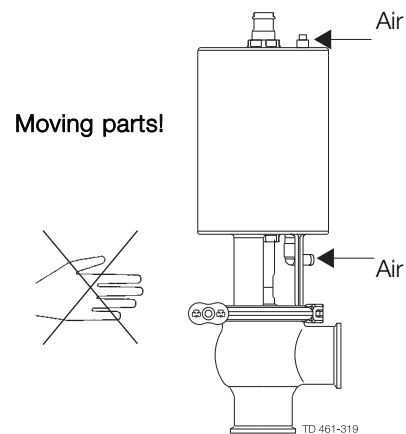

4 Operation

Study the instructions carefully and pay special attention to the warnings!

Ensure that the valve operates smoothly.

The items refer to the parts list and service kits section.

Step 4

Lubrication of valves:

1. Ensure smooth movement between lip seal (25) and plug stem (23, 27).
2. Lubricate with Klüber Paraliq GTE 703 if necessary (see section 4.1).

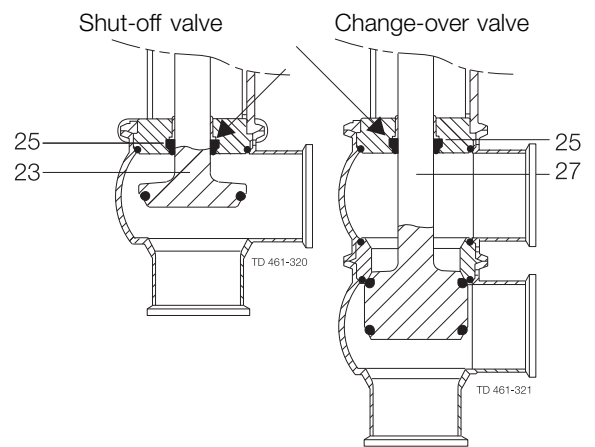

Step 5

Lubrication of actuator

1. Ensure smooth movement of the actuator (the actuator is lubricated before delivery).
2. Lubricate with Molykote Longterm 2 plus if necessary.

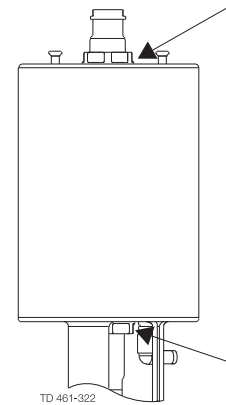

Pay attention to possible faults. Study the instructions carefully.
The items refer to the parts list and service kits section.

4.2 Troubleshooting

NOTE!

Study the maintenance instructions carefully before replacing worn parts. - See section 4.1!

Problem	Cause/result	Repair
External product leakage	Worn or product affected lip seal and/or O-ring	<ul style="list-style-type: none"> - Replace the seals - Replace with seals of a different rubber grade
Internal product leakage	<ul style="list-style-type: none"> - Worn or product affected plug seal - Product deposits on the seat and/or plug - Product pressure exceeds actuator specification 	<ul style="list-style-type: none"> - Replace the seal - Replace with a seal of a different rubber grade - Frequent cleaning - Replace with a high pressure actuator - Use auxiliary air on the spring side (do not exceed 3 bar) - Reduce product pressure
Water hammer	The flow direction is the same as the closing direction	<ul style="list-style-type: none"> - The flow direction should be against the closing direction - Throttle air release of solenoid in top unit
The valve does not open/close	Product pressure exceeds actuator specification	<ul style="list-style-type: none"> - Replace with a high pressure actuator - Use auxiliary air on the spring side - Reduce product pressure

4 Operation

The valve is designed for cleaning in place (CIP). CIP = Cleaning In Place.
 Study the instructions carefully and pay special attention to the warnings!
 NaOH = Caustic Soda.
 HNO₃ = Nitric acid.

4.3 Recommended cleaning

Step 1



Always handle lye and acid with great care.

Caustic danger!



Always use rubber gloves!



Always use protective goggles!

Step 2



Never touch the valve or the pipelines when sterilizing.

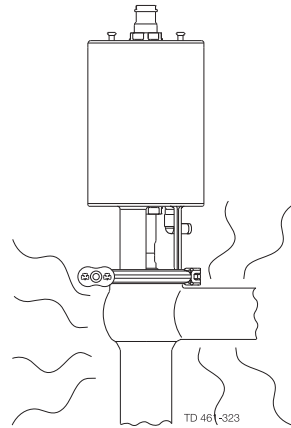

Burning danger!

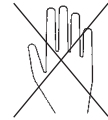

Step 3

Clean the plug and the seats correctly.
Pay special attention to the warnings!
Lift and lower valve plug momentarily!

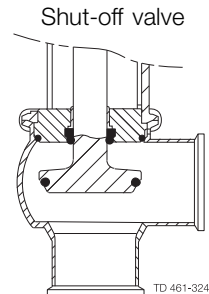

Shut-off valve

TD 461-324

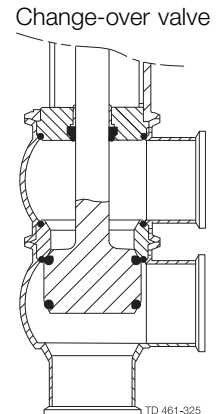

Change-over valve

TD 461-325

Step 4

Examples of cleaning agents:

Use clean water, free from chlorides.

1. 1% by weight NaOH at 158° F

2.2 lb NaOH	+	26.4 gal water	=	Cleaning agent.
----------------	---	-------------------	---	-----------------

0.6 gal 33% NaOH	+	26.4 gal water	=	Cleaning agent.
---------------------	---	-------------------	---	-----------------

2. 0.5% by weight HNO₃ at 158° F

0.2 gal 53% HNO ₃	+	26.4 gal water	=	Cleaning agent.
---------------------------------	---	-------------------	---	-----------------

The valve is designed for cleaning in place (CIP). CIP = Cleaning In Place.
Study the instructions carefully and pay special attention to the warnings!
NaOH = Caustic Soda.
HNO₃ = Nitric acid.

Step 5

1. Avoid excessive concentration of the cleaning agent.
2. Adjust the cleaning flow to the process.
3. **Always** rinse well with clean water after the cleaning.

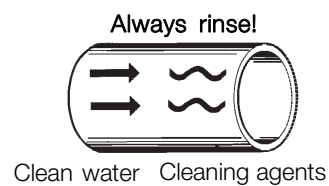

Step 6

NOTE

The cleaning agents must be stored/disposed of in accordance with current regulations/directives.

5 Maintenance

Maintain the valve regularly.

Study the instructions carefully and pay special attention to the warnings!

Always keep spare rubber seals and lip seals in stock.

5.1 General maintenance

Step 1



Always read the technical data thoroughly.
See chapter 5.



Always release compressed air after use.

Step 2



Never service the valve when it is hot.



Never service the valve with valve and pipelines under pressure.

NOTE

All scrap must be stored/discharged in accordance with current rules/directives.

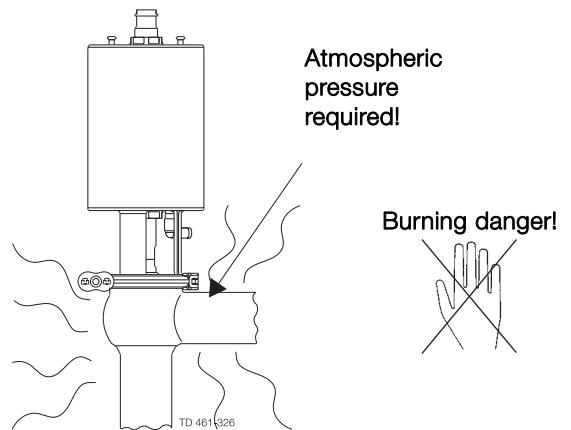

Step 3



Never stick your fingers through the valve ports if the actuator is supplied with compressed air.

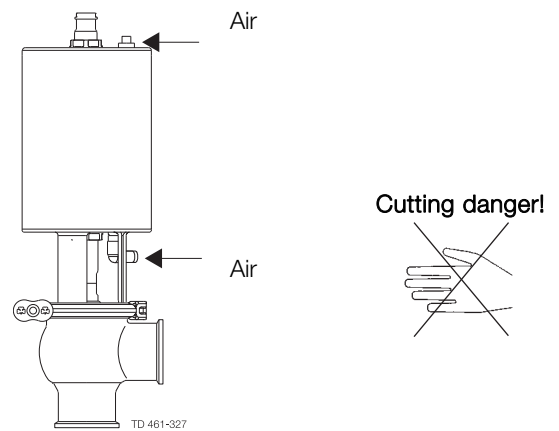

Step 4



Never touch the moving parts if the actuator is supplied with compressed air.

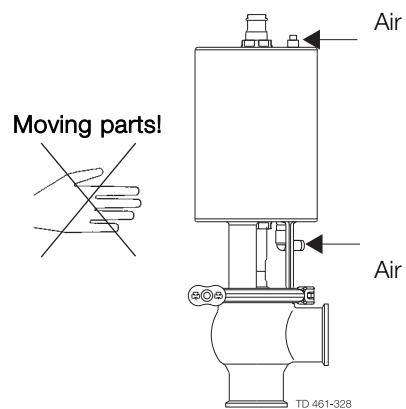

Maintain the valve regularly.

Study the instructions carefully and pay special attention to the warnings!

Always keep spare rubber seals and lip seals in stock.

Below are some guidelines for maintenance and lubrication intervals. Please note that the guidelines are for normal working conditions in one shift.

	Product wetted seals	Actuator bushings complete
Preventive maintenance	Replace after 12 months depending on working conditions	Replace after 5 years depending on working conditions
Maintenance after leakage (leakage normally starts slowly)	Replace at the end of the day	Replace when possible
Planned maintenance	<ul style="list-style-type: none"> - Regular inspection for leakage and smooth operation - Keep a record of the valve - Use the statistics for planning of inspections Replace after leakage	<ul style="list-style-type: none"> - Regular inspection for leakage and smooth operation - Keep a record of the actuator - Use the statistics for planning of inspections Replace after leakage
Lubrication	Before fitting Klüber Paraliq GTE 703 or similar USDA H1 approved oil/grease	Before fitting Molykote Longterm 2 plus

Pre-use check:

1. Supply compressed air to the actuator.
2. Open and close the valve several times to ensure that it operates smoothly.

Pay special attention to the warnings!

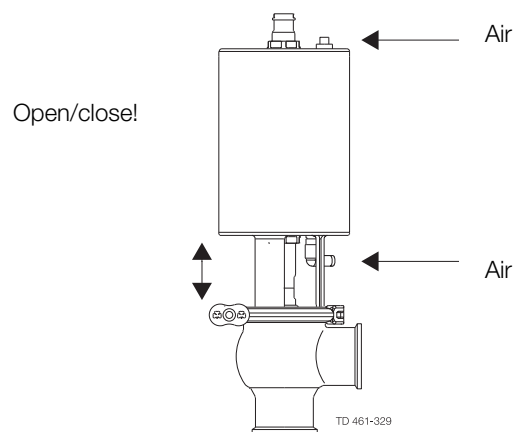

Recommended spare parts

Service kits (see page 25)

5 Maintenance

Study the instructions carefully. The items refer to the parts list and service kits section. Handle scrap correctly.

NC = Normally closed.

NO = Normally open.

A/A = Air/air activated.

5.2 Dismantling of valve

Step 1

1a

Shut-off valve:

1. Supply compressed air to the actuator (only NC).
2. Loosen and remove clamp.
3. Release compressed air (only NC).
4. Lift away the actuator.
5. Unscrew and remove valve plug.
6. Remove O-ring, lip seal and bushing in bonnet.
(Use bushing tool and rubber mallet).

Note! Be careful not to damage the bushing.

Pay special attention to the warnings!

Note! For plug seal replacement please see page 21.

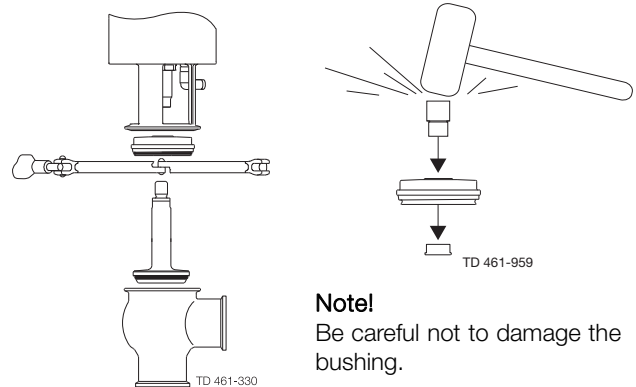

1b

Change-over valve:

1. Supply compressed air to the actuator (only NC).
2. Loosen and remove lower clamp.
3. Release compressed air (only NC).
4. Lift away the actuator and upper valve body.
5. Supply compressed air to the actuator (only NO).
6. Unscrew and remove valve plug.
7. Release compressed air (only NO).
8. Remove seat and O-rings.
9. Loosen and remove upper clamp.
10. Remove upper valve body.
11. Remove O-ring, lip seal and bushing in bonnet.
(Use bushing tool and rubber mallet.
See drawing, step 1a).

Note! Be careful not to damage the bushing.

Pay special attention to the warnings!

Note! For plug seal replacement please see page 21.

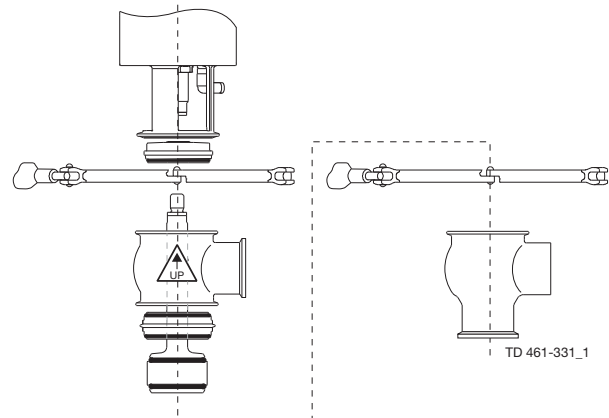

1c

Shut-off valve - Reverse Acting:

1. Loosen and remove lower clamp.
2. Remove lower bonnet and O-ring from lower body.
3. Loosen and remove middle clamp.
4. Lift away the actuator and upper valve body.
5. Supply compressed air to the actuator (only NC).
6. Unscrew and remove valve plug.
7. Release compressed air (only NC).
8. Remove seat and O-rings.
9. Loosen and remove upper clamp.
10. Remove upper valve body.
11. Remove O-ring, lip seal and bushing in bonnet.
(Use bushing tool and rubber mallet.
See drawing, step 1a).

Note! Be careful not to damage the bushing.

Pay special attention to the warnings!

Note! For plug seal replacement please see page 21.

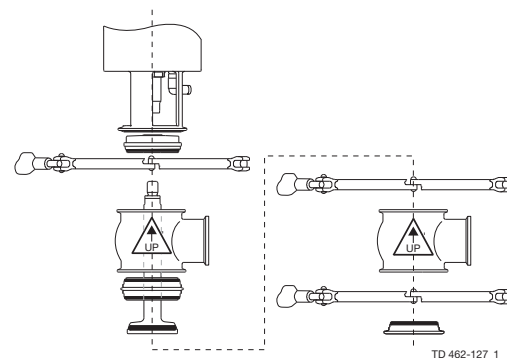

Study the instructions carefully. The items refer to the parts list and service kits section. Handle scrap correctly.

NC = Normally closed.

NO = Normally open.

A/A = Air/air activated.

1d

Change-over valve - Reverse Acting:

1. Loosen and remove lower clamp.
2. Remove lower bonnet and O-ring.
3. Loosen and remove clamp between lower and middle valve body
4. Lift away the actuator and upper + middle valve body.
5. Supply compressed air to the actuator (only NC).
6. Unscrew and remove lower valve plug.
7. Release compressed air (only NC).
8. Remove lower seat and O-rings.
9. Supply compressed air to the actuator (only NO).
10. Loosen and remove clamp between middle and upper valve body.
11. Remove middle valve body and upper seat with O-rings.
12. Release compressed air (only NO).
13. Loosen and remove upper clamp.
14. Remove upper valve body.
15. Unscrew and remove upper valve plug.
16. Remove O-ring, lip seal and bushing in bonnet.
(Use bushing tool and rubber mallet. See drawing, step 1a).

Note! Be careful not to damage the bushing.

Pay special attention to the warnings!

Note! For plug seal replacement please see page 21.

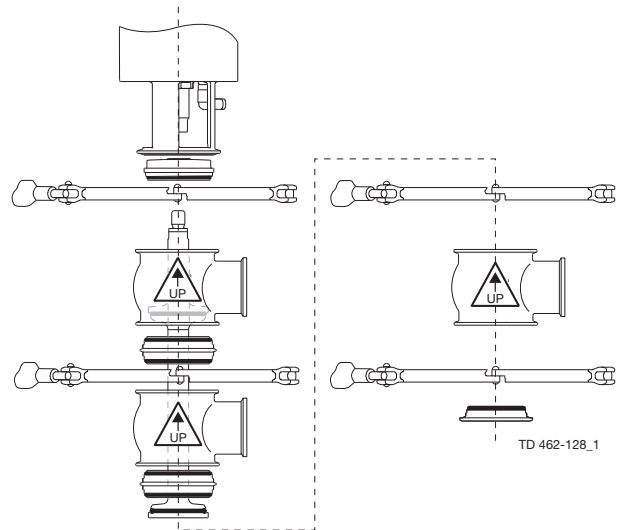

5.3 Elastomer seat ring replacement

1. Remove old seal ring using a knife, screwdriver or similar.
Be careful not to damage metal parts.
2. Pre-mount plug seal without pressing it into the groove.
3. Squeeze plug seal into the groove using opposite pressure points.
4. Release compressed air behind plug seal.

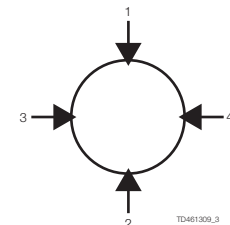

1. Place the plug element on a firm support.
2. Using a utility knife, partially AND CAREFULLY cut through the upper ring portion of the TR2 plug avoiding contact with stainless steel stem.
3. Force apart both cut ends of the plug for removal from stem.
4. TR2 plugs are installed by applying uniform pressure on all sides.
(Pressure can be applied by using the seat assembly tool.)
5. Using a piece of metal and a rubber mallet, place a precise tab to make the TR2 plug snap on to the stem. Reverse the tool and tab again to secure proper fit.
6. Examine seat assembly to be sure the TR2 plug is properly mounted, holding the seat assembly in one hand - rotate the TR2 plug.
(For proper CIP cleaning the TR2 plug should turn freely on the stem.)

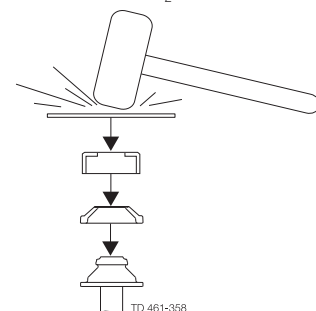

For more explicit instructions, please refer to the maintenance video.

5 Maintenance

Study the instructions carefully.

The items refer to the parts list and service kits section. Handle scrap correctly.

A/A = Air/air activated.

Service tool: See Spare Parts.

5.4 Assembly of valve

Reverse order of 4.2, Dismantling of valve.

Lubricate O-ring (21) and lip seal (25) with Klüber Paraliq GTE 703.

Remember to tighten spindle and plug with a torque $M = 23 \text{ lbf-ft}$ (30 Nm) (Use two 17 mm spanners)

If there are vibrations in the pipeline Alfa Laval recommend to use loctite nr. 243.

5.5 Actuator bushing replacement

1. Unscrew and remove top and bottom bushings with O-rings.
2. Lubricate O-rings with Molykote Longterm 2 plus before fitting.
3. Fit bushings and O-rings. Tighten brushing with a torque = 7 lbf-ft (10Nm).
Be careful not to overtighten.

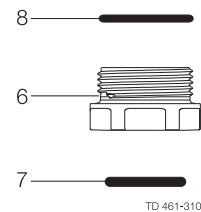

5.6 Dismantling of optional maintainable actuator

1. Rotate cylinder.
2. Remove lock wire and pull away cylinder.
3. Unscrew nuts and remove yoke.
4. Unscrew top and bottom bushings.
5. Remove piston with O-ring and spring assembly.
6. Remove O-rings and support disc.

Rotate cylinder with
service tool.

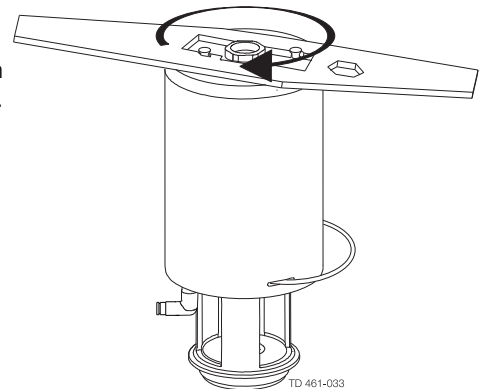

Note! The A/A actuator has no spring assembly.

5.7 Assembly of optional maintainable actuator

Reverse order of 4.6. Dismantling of actuator.

Lubricate O-ring (3, 7, 11) with Molykote Longterm 2 plus before fitting.

Study the instructions carefully.
The items refer to the parts list and service kits section. Handle scrap correctly.
A/A = Air/air activated.
Service tool: See Spare Parts.

5.8 Reversing optional maintainable actuator operation

- 1. Rotate cylinder.
- 2. Remove lock wire and pull away cylinder.
- 3. Reverse piston and spring assembly.
- 4. Reverse adapter, air fitting and plug to opposite end.
- 5. Re-assemble in reverse order (3 to 1).

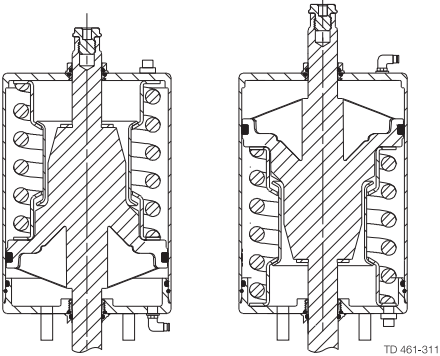

Pneumatic movement upwards

Pneumatic movement downwards

6 Technical data

*It is important to observe the technical data during installation, operation and maintenance.
Inform the personnel about the technical data.*

6.1 Technical data

Data - valve/actuator	
Max. product pressure	145 PSI (1000 kPa) (10 bar)
Min. product pressure	Full vacuum (depending on product specifications)
Temperature range	14° F to + 284° F (standard EPDM seal)
Air pressure, actuator	72.5 to 101.5 PSI (500 to 700 kPa) (5 to 7 bar)
Materials - valve/actuator	
Product wetted steel parts	AISI 316L (internal Ra < 32 µ inch)
Other steel parts	AISI 304
Plug seal	EPDM / PTFE (TR2)
Other product wetted seals	EPDM (standard)
Optional product wetted seals	HNBR and FPM
Other seals	NBR

Noise

One meter away from - and 1.6 meter above the exhaust the noise level of a valve actuator will be approximately 77db(A) without noise damper and approximately 72 db(A) with damper - Measured at 7 bars air-pressure.

7 Parts list and Service Kits

The drawing shows Unique 7000 Series Valve.
 The items refer to the parts lists in the following sections.

7.1 Drawing

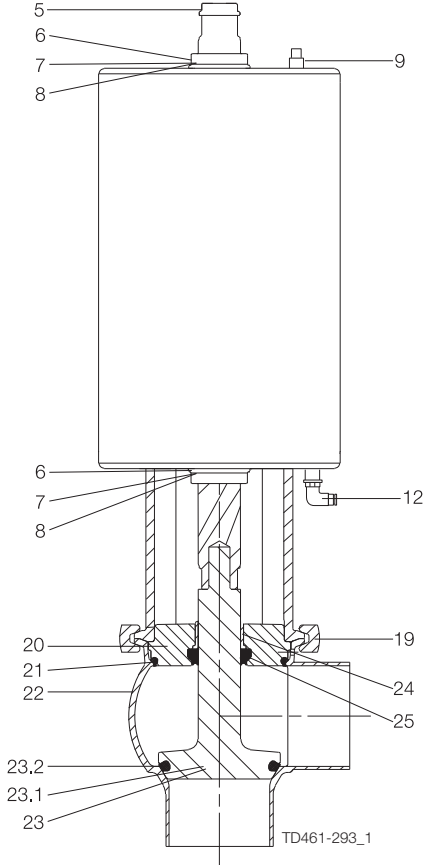

Shut-off valve (elastomer)

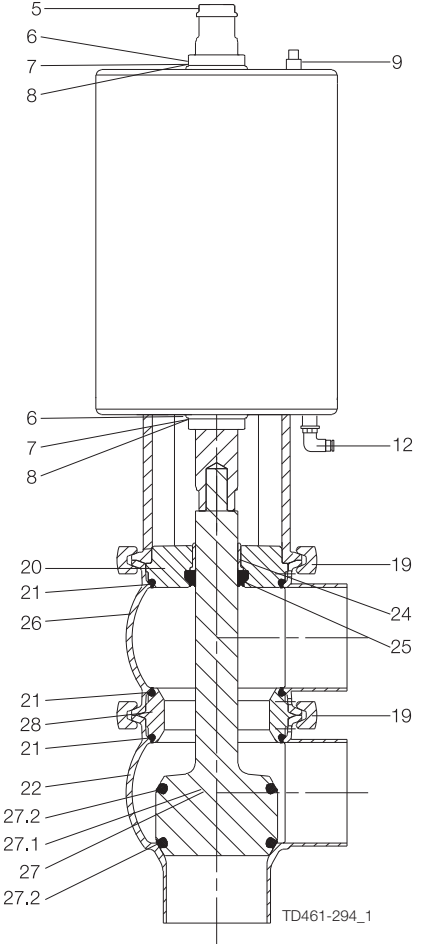

Change-over valve (elastomer)

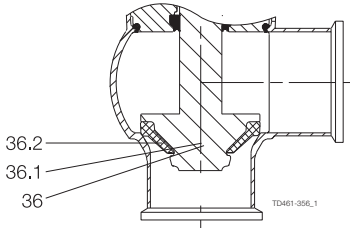

Shut-off valve (TR2)

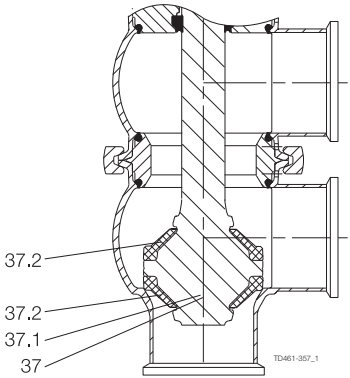

Shut-off valve (TR2)

7 Parts list and Service Kits

The drawing shows Unique 7000 TR2 - Shut-off-Valve.
The items refer to the parts lists in the following sections.

7.2 Unique 7000 TR2 - Shut-off-Valve

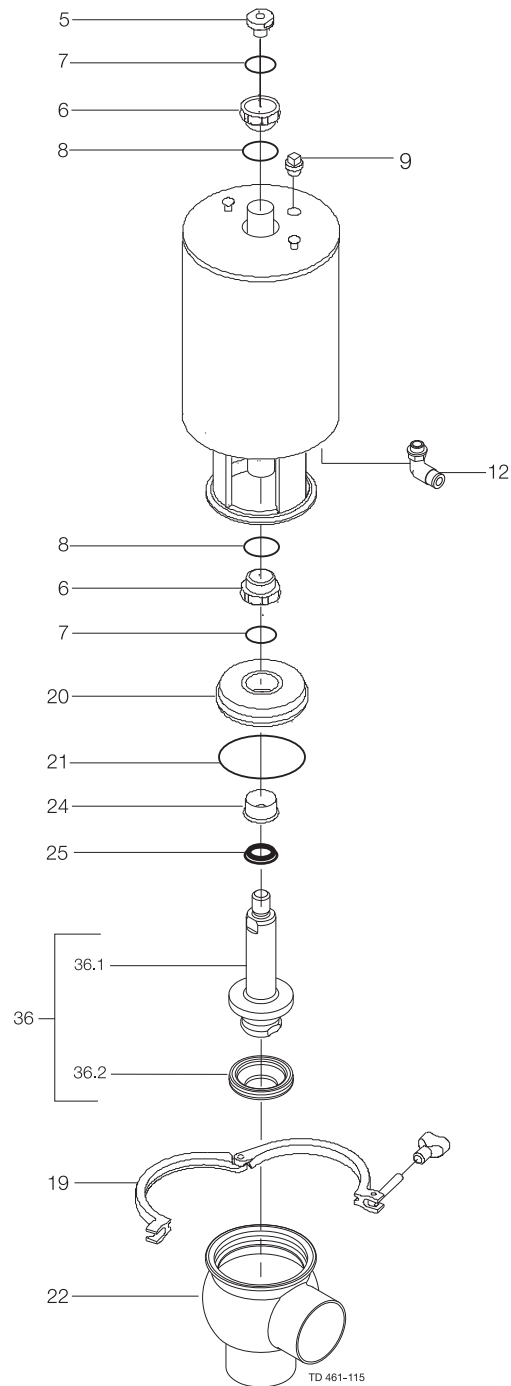

7 Parts list and Service Kits

The drawing shows Unique 7000 TR2 - Shut-off-Valve.
The items refer to the parts lists in the following sections.

Parts list

Pos.	Qty	Denomination
6 □	2	Bushing
7 □	2	O-ring
8 □	2	O-ring
21 ◆	1	O-ring, EPDM
	1	O-ring
	1	O-ring
25 ◆	1	Lip seal
	1	Lip seal
	1	Lip seal

Service kits

Denomination	1"	1 1/2"	2"	2 1/2"	3"	4"
□ Service kit, actuator	9611-92-6500	9611-92-6500	9611-92-6500	9611-92-6500	9611-92-6500	9611-92-6500
◆ Service Kit, EPDM	9611-92-6576	9611-92-6561	9611-92-6562	9611-92-6563	9611-92-6564	9611-92-6565
◆ Service kit, HNBR	9611-92-6577	9611-92-6566	9611-92-6567	9611-92-6568	9611-92-6569	9611-92-6570
◆ Service kit, FPM	9611-92-6578	9611-92-6571	9611-92-6572	9611-92-6573	9611-92-6574	9611-92-6575

7 Parts list and Service Kits

The drawing shows Unique 7000 TR2 - Change-over-Valve.
The items refer to the parts lists in the following sections.

7.3 Unique 7000 TR2 - Change-over-Valve

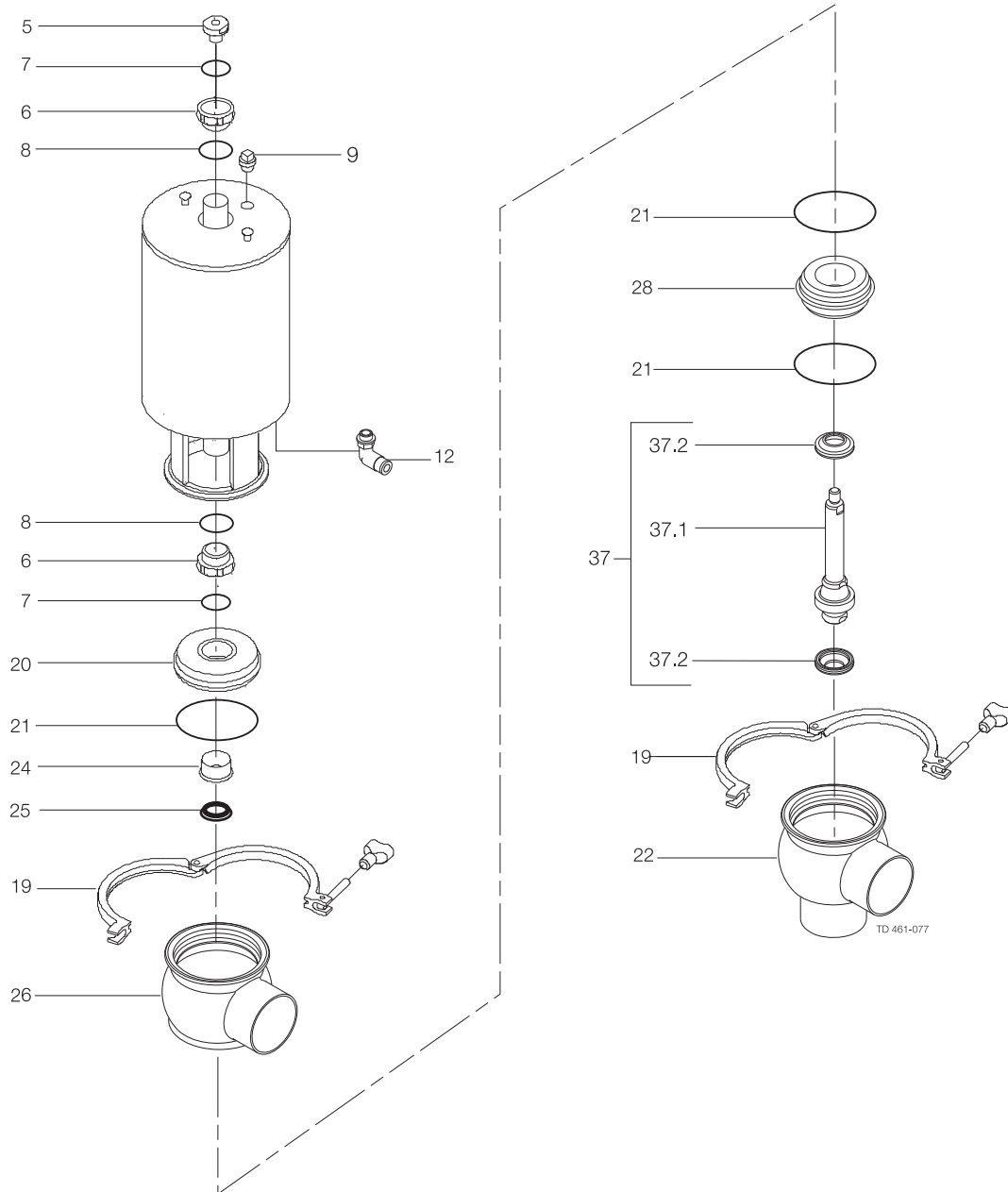

7 Parts list and Service Kits

The drawing shows Unique 7000 TR2 - Change-over-Valve.
 The items refer to the parts lists in the following sections.

Parts list

Pos.	Qty	Denomination
6	2	Bushing
7	2	O-ring
8	2	O-ring
21	3	O-ring, EPDM
	3	O-ring
	3	O-ring
25	1	Lip seal
	1	Lip seal
	1	Lip seal
37.2	2	Plug seal

Service kits

Denomination	1 1/2"	2"	2 1/2"	3"	4"
□ Service kit, actuator	9611-92-6500	9611-92-6500	9611-92-6500	9611-92-6500	9611-92-6500
♦ Service Kit, EPDM	9611-92-6633	9611-92-6634	9611-92-6635	9611-92-6636	9611-92-6637
♦ Service kit, HNBR	9611-92-6638	9611-92-6639	9611-92-6640	9611-92-6641	9611-92-6642
♦ Service kit, FPM	9611-92-6643	9611-92-6644	9611-92-6645	9611-92-6646	9611-92-6647

7 Parts list and Service Kits

The drawing shows Unique 7000 Elastomer plug seal - Shut-off-Valve.
The items refer to the parts lists in the following sections.

7.4 Unique 7000 Elastomer plug seal - Shut-off-Valve

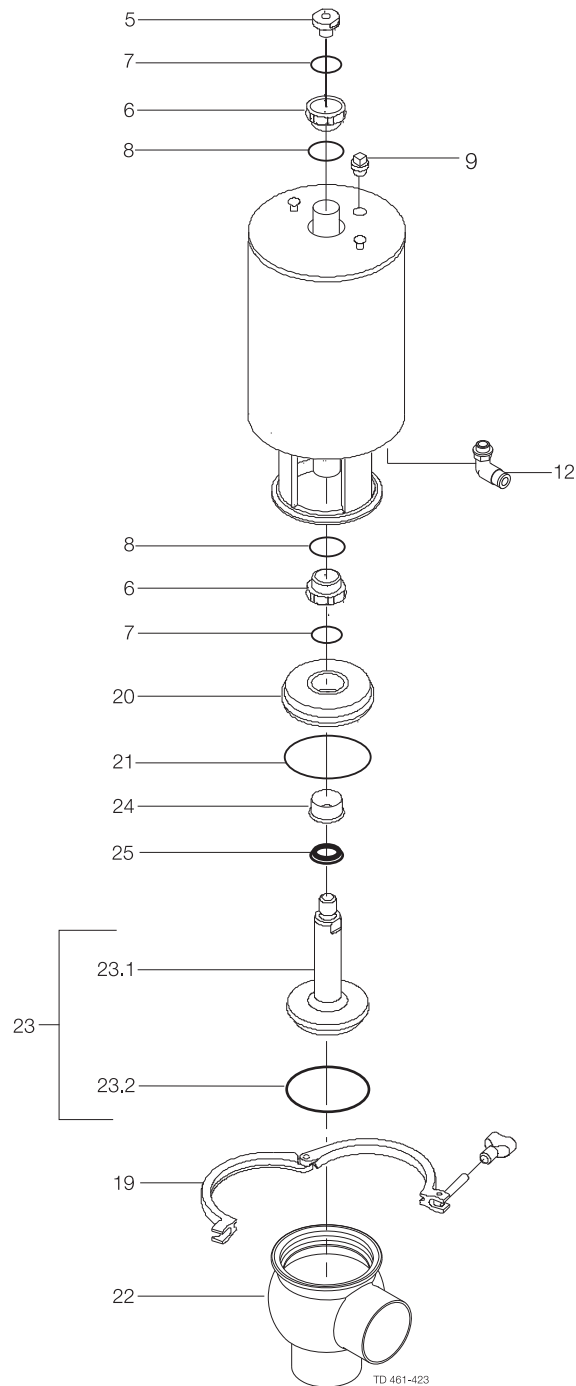

7 Parts list and Service Kits

The drawing shows Unique 7000 Elastomer plug seal - Shut-off-Valve.
The items refer to the parts lists in the following sections.

Parts list

Pos.	Qty	Denomination
6 □	2	Bushing
7 □	2	O-ring
8 □	2	O-ring
21 ◆	1	O-ring, EPDM
	1	O-ring
	1	O-ring
	1	Valve body, lower, 3 ports
23.1	1	Plug
23.2 ◆	1	Plug seal
	1	Plug seal
25 ◆	1	Lip seal
	1	Lip seal
	1	Lip seal

Service kits

Denomination	1"	1 1/2"	2"	2 1/2"	3"	4"
--------------	----	--------	----	--------	----	----

Recommended spare parts; Service kits.

□	Service kit, actuator	9611-92-6500	9611-92-6500	9611-92-6500	9611-92-6500	9611-92-6500	9611-92-6500
◆	Service Kit, EPDM	9611-92-6501	9611-92-6502	9611-92-6503	9611-92-6504	9611-92-6505	9611-92-6506
◆	Service kit, HNBR	9611-92-6507	9611-92-6508	9611-92-6509	9611-92-6510	9611-92-6511	9611-92-6512
◆	Service kit, FPM	9611-92-6513	9611-92-6514	9611-92-6515	9611-92-6516	9611-92-6517	9611-92-6518

7 Parts list and Service Kits

The drawing shows Unique 7000 Elastomer plug seal - Change-over-Valve.
The items refer to the parts lists in the following sections.

7.5 Unique 7000 Elastomer plug seal - Change-over-Valve

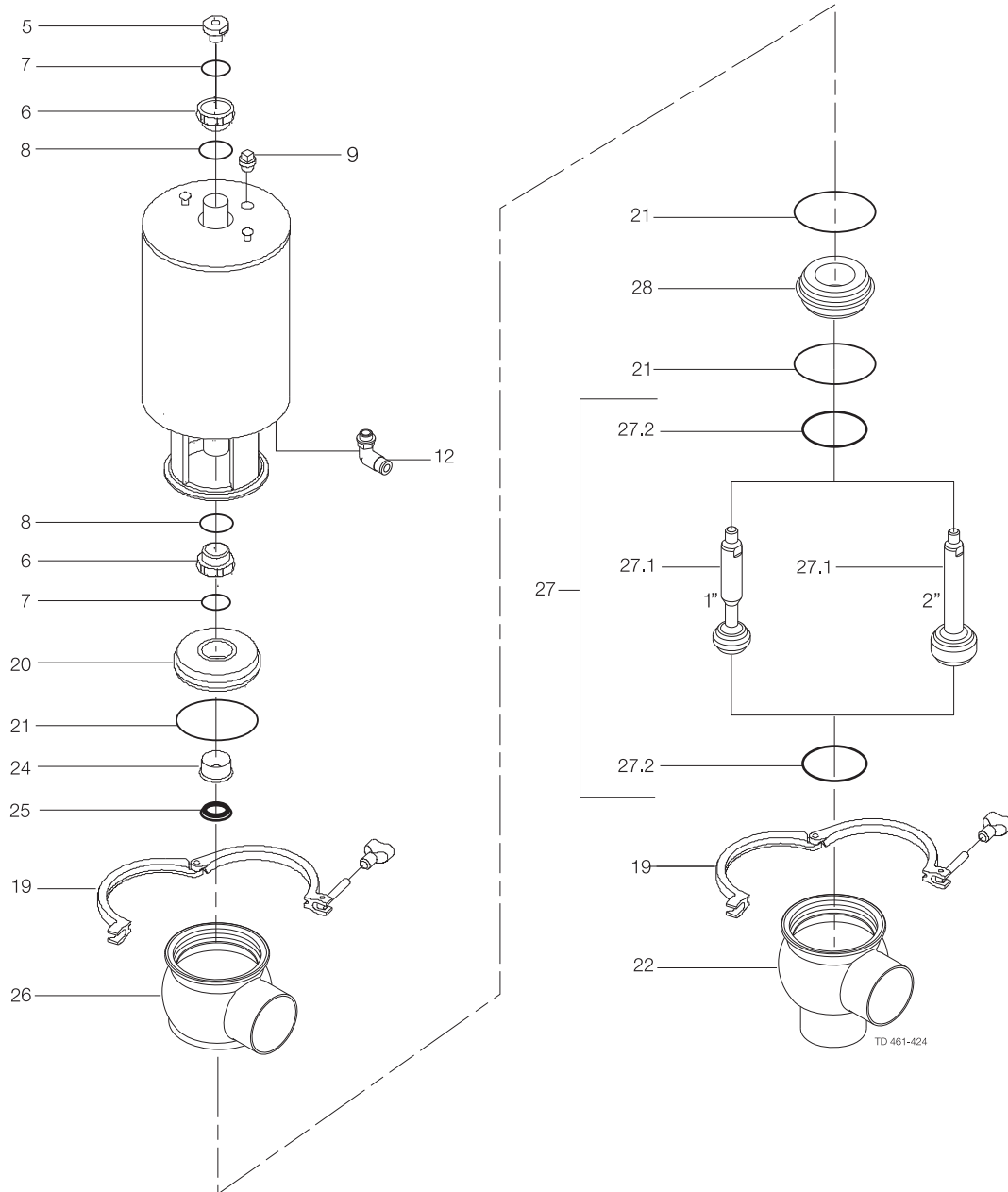

7 Parts list and Service Kits

The drawing shows Unique 7000 Elastomer plug seal - Change-over-Valve.
The items refer to the parts lists in the following sections.

Parts list

Pos.	Qty	Denomination
6 □	2	Bushing
7 □	2	O-ring
8 □	2	O-ring
21 ◆	3	O-ring, EPDM
	3	O-ring
	3	O-ring
25 ◆	1	Lip seal
	1	Lip seal
	1	Lip seal
27.2 ◆	2	Plug seal
	2	Plug seal
	2	Plug seal

Service kits

Denomination	1"	1 1/2"	2"	2 1/2"	3"	4"
Recommended spare parts; Service kits.						
□ Service kit, actuator	9611-92-6500	9611-92-6500	9611-92-6500	9611-92-6500	9611-92-6500	9611-92-6500
◆ Service Kit, EPDM	9611-92-6579	9611-92-6580	9611-92-6581	9611-92-6582	9611-92-6583	9611-92-6584
◆ Service kit, HNBR	9611-92-6585	9611-92-6586	9611-92-6587	9611-92-6588	9611-92-6589	9611-92-6590
◆ Service kit, FPM	9611-92-6591	9611-92-6592	9611-92-6593	9611-92-6594	9611-92-6595	9611-92-6596

How to contact Alfa Laval

Contact details for all countries are continually updated on our website.

Please visit www.alfalaval.com to access the information directly.

© Alfa Laval Corporate AB

This document and its contents is owned by Alfa Laval Corporate AB and protected by laws governing intellectual property and thereto related rights. It is the responsibility of the user of this document to comply with all applicable intellectual property laws. Without limiting any rights related to this document, no part of this document may be copied, reproduced or transmitted in any form or by any means (electronic, mechanical, photocopying, recording, or otherwise), or for any purpose, without the expressed permission of Alfa Laval Corporate AB. Alfa Laval Corporate AB will enforce its rights related to this document to the fullest extent of the law, including the seeking of criminal prosecution.