

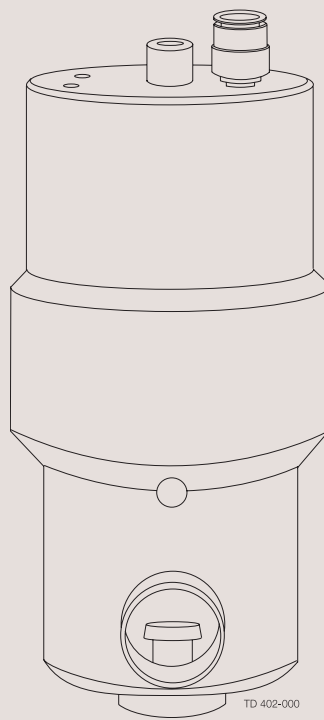

Instruction Manual

LKAP Air-Operated Valve



ESE01993-EN4 2011-02

Original manual

The information herein is correct at the time of issue but may be subject to change without prior notice

1. Declaration of Conformity	4
2. Safety	5
2.1. Important information	5
2.2. Warning signs	5
2.3. Safety precautions	6
3. Installation	7
3.1. Unpacking/Delivery/General installation	7
3.2. General installation	8
3.3. Welding	10
4. Operation	12
4.1. General operation	12
4.2. Fault finding	13
4.3. Recommended cleaning	14
5. Maintenance	16
5.1. General maintenance	16
5.2. Dismantling	18
5.3. Assembly	21
6. Technical data	24
6.1. Technical data	24
7. Air-Operated Valves with Welding Ends - LKAP-V & LKAP-T	25
8. Reed Type Double Signalling Unit for Valve LKAP	27

1 Declaration of Conformity

The designating company

Alfa Laval

Company Name

Albuen 31, DK-6000 Kolding, Denmark

Address

+45 79 32 22 00

Phone No.

hereby declare that

Valve

Denomination

LKAP

Type

Year

is in conformity with the following directives:
- Machinery Directive 2006/42/EC

Pressure Equipment Directive 97/23/EC category 1 and subjected to assessment procedure, Module A.

Manager, Product Centres,
Compact Heat Exchangers & Fluid Handling

Title

Bjarne Søndergaard

Name

Alfa Laval Kolding
Company

Signature



Designation



*Unsafe practices and other important information are emphasized in this manual.
Warnings are emphasized by means of special signs.*

2.1 Important information

Always read the manual before using the valve!

WARNING

Indicates that special procedures must be followed to avoid serious personal injury.

CAUTION

Indicates that special procedures must be followed to avoid damage to the valve.

NOTE

Indicates important information to simplify or clarify procedures.

2.2 Warning signs

General warning:



Caustic agents:



2 Safety

All warnings in the manual are summarized on this page.

Pay special attention to the instructions below so that severe personal injury and/or damage to the valve are avoided.

2.3 Safety precautions

Installation:

Always observe the technical data (See chapter)

Always release compressed air after use.



Operation:

Always observe the technical data (See chapter)

Never touch the valve or the pipelines when processing hot liquids or when sterilizing



Always handle lye and acid with great care



Maintenance:

- **Always** observe the technical data (See chapter)

- **Always** release compressed air after use

- The valve must **Never** be hot when servicing it

- The valve/actuator and the pipelines must never be pressurised when servicing the valve/ actuator

- **Never** stick your fingers through the valve ports if the valve is supplied with compressed air.



Transportation:

Always secure that compressed air is released

Always secure that all connections is disconnected before attempt to remove the valve from the installation

Always drain liquid out of valves before transportation

Always used predesigned lifting points if defined

Always secure sufficient fixing of the valve during transportation - if special designed packaging material is available it must be used

The instruction manual is part of the delivery.

Study the instructions carefully.

LKAP-V: Valve body with two valve ports.

LKAP-T: Valve body with three valve ports.

3.1 Unpacking/Delivery/General installation

Unpacking/delivery

Step 1

CAUTION

Alfa Laval cannot be held responsible for incorrect unpacking.

Check the delivery:

1. Complete valve, LKAP-V or LKAP-T
 2. Delivery note
 3. Instruction Manual
-

Step 2

1. Clean the valve for possible packing materials
2. Inspect the valve for visible transport damage
3. Avoid damaging the valve

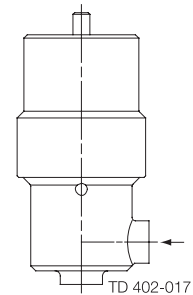

3 Installation

Study the instructions carefully and pay special attention to the warnings!

The valve has welding ends as standard but can also be supplied with fittings.

NO = Normally open.

NC = Normally closed.

3.2 General installation

Step 1



Always read the technical data thoroughly.

See chapter



Always release compressed air after use.

CAUTION

Alfa Laval cannot be held responsible for incorrect installation.

Step 2

Flow direction:

To avoid pressure shocks it is recommended to install the valve with inlet through the bottom connection.

- I: Inlet
- O: Outlet

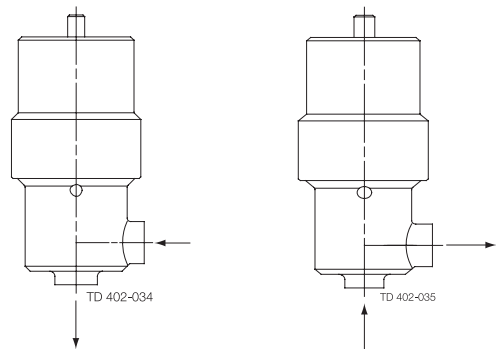

Step 3

Avoid stressing the valve.

- Vibrations
- Thermal expansion of the tubes
- Excessive welding
- Overloading of the pipelines

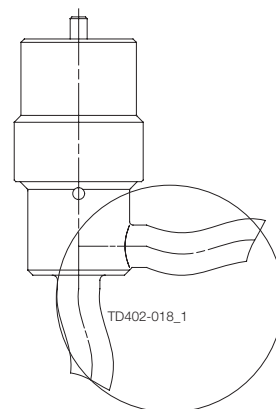

3 Installation

Study the instructions carefully and pay special attention to the warnings!
The valve has welding ends as standard but can also be supplied with fittings.
NO = Normally open.
NC = Normally closed.

Step 4

Fittings:

Ensure that the connections are tight (remember seal rings).

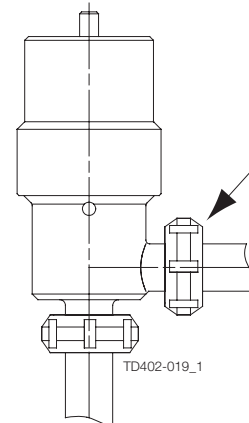

Step 5

Air connection: R 1/8" (BSP).

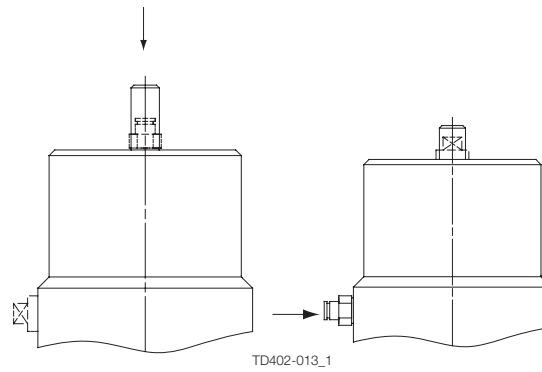

3 Installation

Study the instructions carefully.

The items refer to the drawings and the parts list in section 6.1.

Check the valve for smooth operation after welding.

3.3 Welding

Step 1

1. Turn air cylinder (2) anticlockwise by hand with a strap wrench or with a spanner.
2. Remove the air cylinder from valve body (15).

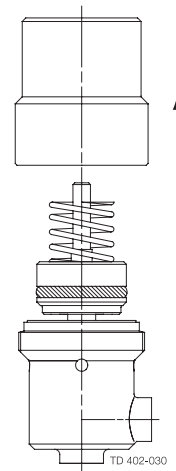

Step 2

1. Remove spring (5) and the rest of the internal valve parts from valve body (15).

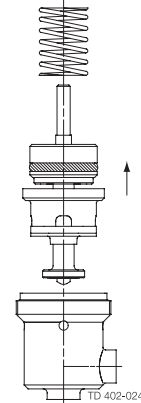

Step 3

1. Weld valve body (15) into the pipelines
2. Maintain the minimum clearance so that the internal valve parts can be removed.

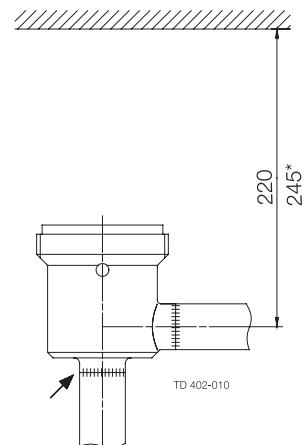

Step 4

1. Assemble the valve in accordance with the instructions in section 4.3.

Study the instructions carefully.

The items refer to the drawings and the parts list in section 6.1.

Check the valve for smooth operation after welding.

Step 5

Pre-use check:

1. Supply compressed air to the valve
2. Open and close the valve several times to ensure that it operates smoothly.

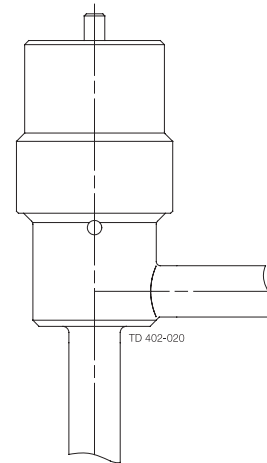

Pay special attention to the warnings!

Recycling information.

Unpacking

- Packing material consists of wood, plastics, cardboard boxes and in some cases metal straps.
- Wood and cardboard boxes can be reused, recycled or used for energy recovery.
- Plastics should be recycled or burnt at a licensed waste incineration plant.
- Metal straps should be sent for material recycling.

Maintenance

- During maintenance oil and wear parts in the machine are replaced.
- All metal should be sent for material recycling.
- Worn out or defective electronic parts should be sent to a licensed handler for material recycling.
- Oil and all non metal wear parts must be taken care of in agreement with local regulations.

Scrapping

- At end of use, the equipment shall be recycled according to relevant, local regulations. Beside the equipment itself, any hazardous residues from the process liquid must be considered and dealt with in a proper manner. When in doubt, or in the absence of local regulations, please contact the local Alfa Laval sales company.
-

4 Operation

Study the instructions carefully and pay special attention to the warnings!
Ensure that the valve operates smoothly.
Pay attention to possible faults.
The items refer to the drawings and the parts list in section 6.1.

4.1 General operation

Step 1



Always read the technical data thoroughly.
(see chapter)



Always release compressed air after use.

CAUTION

Alfa Laval cannot be held responsible for incorrect operation.

Step 2



Never touch the valve or the pipelines when processing hot liquids
or when sterilizing.

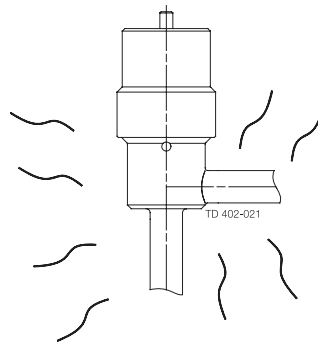

**Burning
danger!**

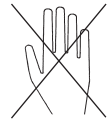

Study the instructions carefully and pay special attention to the warnings!

Ensure that the valve operates smoothly.

Pay attention to possible faults.

The items refer to the drawings and the parts list in section 6.1.

4.2 Fault finding

NOTE

Study the maintenance instructions carefully before replacing worn parts. - See

Problem	Cause/result	Repair
Product leakage through the drain holes	Worn/product affected lip seal (11)	Replace the lip seal Select a different rubber grade
Leakage at the valve plug	Worn/product affected O-ring (13)	Replace the O-ring Select a different rubber grade
Air leakage through the drain holes	Worn actuator O-rings	Replace the O-rings
Air leakage between air cylinder (2) and valve body (15), (threaded connection)	Worn O-ring (9) Loose air cylinder (2)	Replace all seals Select another elastomer sealing material grade Change operating conditions

4 Operation

The valve is designed for cleaning in place (CIP).

CIP = Cleaning In Place.

Study the instructions carefully and pay special attention to the warnings!

NaOH = Caustic Soda. HNO₃ = Nitric acid.

4.3 Recommended cleaning

Step 1



Always handle lye and acid with great care.

Caustic danger!



Always use
rubber gloves!



Always use
protective goggles!

Step 2



Never touch the valve or the pipelines when sterilizing.

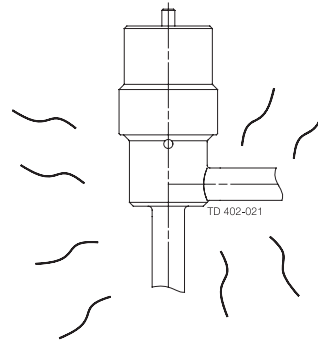

**Burning
danger!**

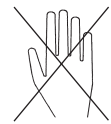

Step 3

Examples of cleaning agents:

Use clean water, free from chlorides.

1. 1% by weight NaOH at 70° C

1 kg (2.2 lbs) NaOH	+	100 l (26.4 gal) water	=	Cleaning agent.
------------------------	---	---------------------------	---	-----------------

2.2 l (0.58 gal) 33% NaOH	+	100 l (26.4 gal) water	=	Cleaning agent.
------------------------------	---	---------------------------	---	-----------------

2. 0.5% by weight HNO₃ at 70° C (158°F)

0.7 l (0.18 gal) 53% HNO ₃	+	100 l (26.4 gal) water	=	Cleaning agent.
--	---	---------------------------	---	-----------------

1. Avoid excessive concentration of the cleaning agent

⇒ **Dose gradually!**

2. Adjust the cleaning flow to the process

⇒ **Sterilization of milk/viscous liquids**
⇒ **Increase the cleaning flow!**

The valve is designed for cleaning in place (CIP).

CIP = Cleaning In Place.

Study the instructions carefully and pay special attention to the warnings!

NaOH = Caustic Soda. HNO₃ = Nitric acid.

Step 4

Always rinse well with clean water after the cleaning.

CAUTION! The cleaning agents must be stored/disposed of in accordance with current rules/directives.

Always rinse!

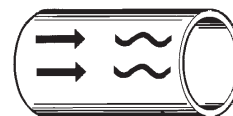

Clean water Cleaning agents

5 Maintenance

Maintain the valve and the actuator carefully.
Study the instructions carefully and pay special attention to the warnings!
Always keep service kits in stock.

5.1 General maintenance

Step 1



Always read the technical data thoroughly.
See chapter 5



Always release compressed air after use.

NOTE

All scrap must be stored/discharged in accordance with current rules/directives.

Step 2



Never service the valve when it is hot.
The valve/actuator and the pipelines must **never** be pressurised when servicing the valve/actuator.

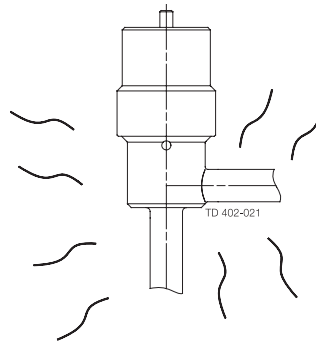

Atmospheric pressure required!

Burning danger!

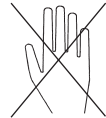

Maintain the valve and the actuator carefully.

Study the instructions carefully and pay special attention to the warnings!

Always keep service kits in stock.

Recommended spare parts:

Service kits (see chapter 6).

Order service kits from the service kits list (see chapter 6).

	Valve lip seal	Valve O-rings	Actuators O-rings
Preventive maintenance	Replace after 12 months	Replace when replacing the lip seal	Replace after 5 years
Maintenance after leakage (leakage normally starts slowly)	Replace at the end of the day	Replace when replacing the lip seal	Replace when necessary
Planned maintenance	<ul style="list-style-type: none"> - Regular inspection for leakage and smooth operation - Keep a record of the valve - Use the statistics for planning of inspections Replace after leakage	<ul style="list-style-type: none"> - Replacing when replacing the lip seal 	<ul style="list-style-type: none"> - Regular inspection for leakage and smooth operation - Keep a record of the valve - Use the statistics for planning for planning of inspections Replace after air leakage
Lubrication	Before fitting <ul style="list-style-type: none"> - Silicone grease or silicone oil 	None	Before fitting <ul style="list-style-type: none"> - Grease or oil

5 Maintenance

Study the instructions carefully.

The items refer to the drawings and the parts list in section 6.1.

5.2 Dismantling

Step 1

1. Turn air cylinder (2) anticlockwise by hand with a strap wrench or with a spanner
2. Remove the air cylinder from valve body (15)
3. Pull out O-ring (3) from the air cylinder

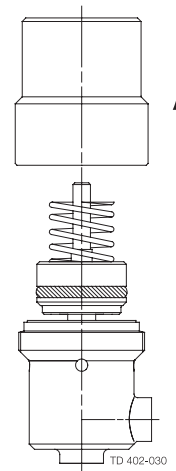

Step 2

2. Remove spring (5) and the rest of the internal parts from valve body (15).

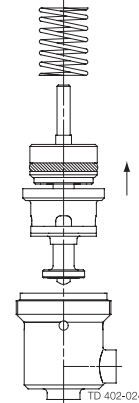

Step 3

1. Turn nut (4) anticlockwise and remove it from valve plug unit (12, 14)
2. Remove screw (1) from the nut

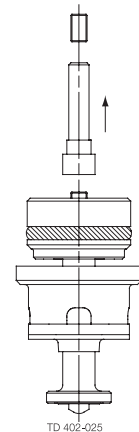

Study the instructions carefully.

The items refer to the drawings and the parts list in section 6.1.

Step 4

1. Separate piston (6) from valve plug unit (12, 14)
2. Pull off O-ring (7) from the piston

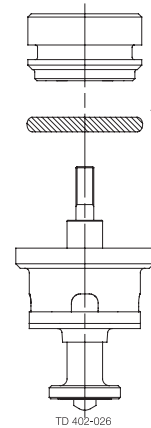

Step 5

1. Slide off bottom piece (10) from valve plug unit (12, 14)
2. Remove O-rings (8, 9) from the bottom piece

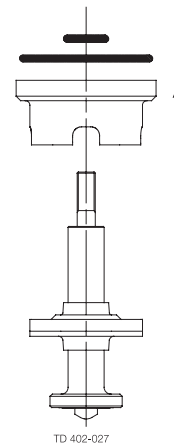

Step 6

1. Pull off lip seal (11) from valve plug unit (12, 14).

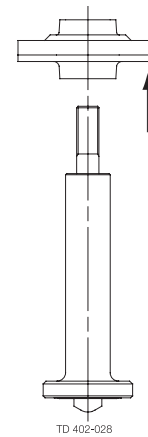

5 Maintenance

Study the instructions carefully.

The items refer to the drawings and the parts list in section 6.1.

Step 7

1. Remove hollow spindle (12) from valve spindle (14)
2. Pull out O-ring (13) from the hollow spindle

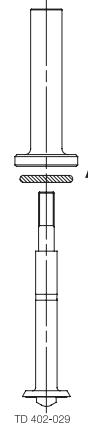

Study the instructions carefully.
The items refer to the drawings and the parts list in section 6.1.
Lubricate the rubber seals before fitting them.

5.3 Assembly

Step 1

- 1. Fit O-ring (13) in hollow spindle (12)
- 2. Slide the hollow spindle onto valve spindle (14)

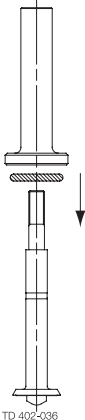

Step 2

- Fit lip seal (11) on valve plug unit (12, 14)

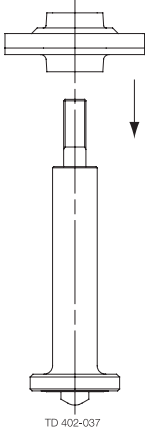

Step 3

- 1. Fit O-rings (8, 9) into the grooves of bottom piece (10)
- 2. Slide the bottom piece onto valve plug unit (12, 14)

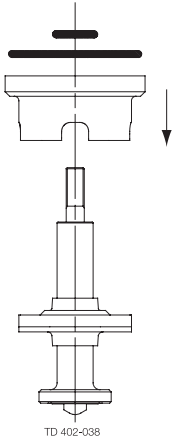

5 Maintenance

Study the instructions carefully.

The items refer to the drawings and the parts list in section 6.1.

Lubricate the rubber seals before fitting them.

Step 4

1. Fit O-ring (7) on piston (6)
2. Guide the piston onto valve plug unit (12, 14)

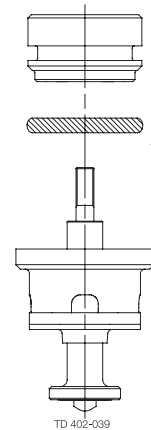

Step 5

1. Fit screw (1) in indication nut (4)
2. Guide the indication nut onto valve plug unit (12, 14), turn it clockwise and tighten

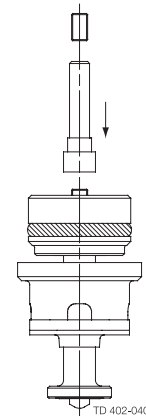

Step 6

1. Position spring (5) in the groove of piston (6)
2. Fit valve plug unit (12, 14) with the internal parts into valve body (15)

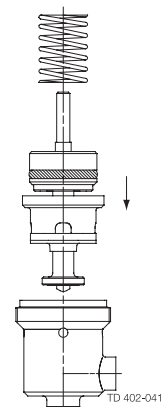

Step 7

1. Slide O-ring (3) into the groove of air cylinder (2)
2. Fit the air cylinder on valve body (15), turn it clockwise and tighten by hand with a strap wrench or with a spanner

NOTE!

Fix bottom piece (10) by means of two $\varnothing 6$ mm mandrels so that a free discharge from the drain holes is maintained.

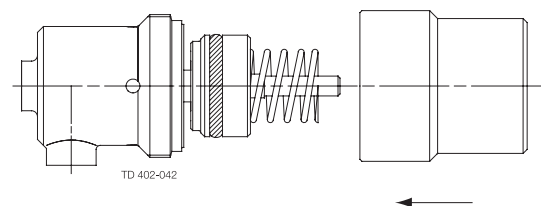

Study the instructions carefully.

The items refer to the drawings and the parts list in section 6.1.

Lubricate the rubber seals before fitting them.

Step 8

Pre-use check:

1. Supply compressed air to the valve
2. Open and close the valve several times to ensure that it operates smoothly

Pay special attention to the warnings!

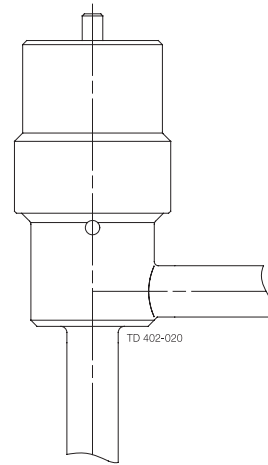

6 Technical data

It is important to observe the technical data during installation, operation and maintenance.

Inform the personnel about the technical data.

NO = Normally open.

NC = Normally closed.

6.1 Technical data

Data- valve/actuator	
Max. product pressure	1000 kPa (10 bar)
Max. recommended pressure the plug (NC)	600 kPa (6 bar)
Flow Kv ($\Delta p = 1$ bar)	9 m ³ /h
Temperature range	-10° C to + 140° C (EPDM).
Min. air pressure	500 kPa (5 bar)
Materials	
Product wetted steel parts	AISI 316L
Other steel parts	Semi bright
Surface quality, product wetted parts	AISI 304
Other seals	Nitrile (NBR), (standard)
External surface finish, actuator	Nitrile (NBR)
Alternative product wetted seals	EPDM and Fluorinated rubber (FPM)

Noise

A bracket for standard M12 sensors is available for the LKAP valve (see ordering leaflet)

One meter away from - and 1.6 meter above the exhaust the noise level of a valve actuator will be approximately 77db(A) without noise damper and approximately 72 db (A) with damper - Measured at 7 bars air-pressure.

7 Air-Operated Valves with Welding Ends - LKAP-V & LKAP-T

It is important to observe the technical data during installation, operation and maintenance.
Inform the personnel about the technical data.
NO = Normally open.
NC = Normally closed.

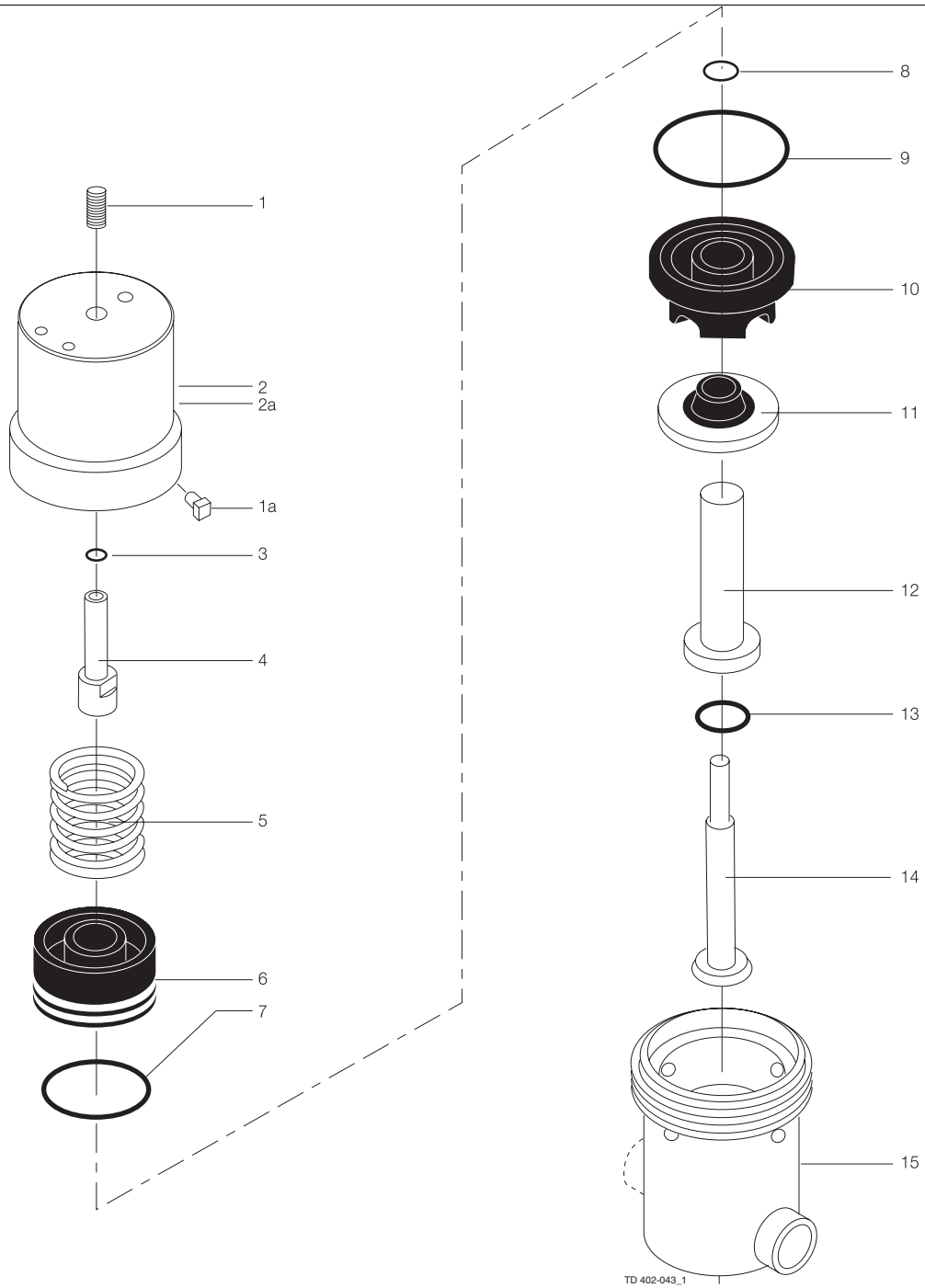

7 Air-Operated Valves with Welding Ends - LKAP-V & LKAP-T

It is important to observe the technical data during installation, operation and maintenance.

Inform the personnel about the technical data.

NO = Normally open.

NC = Normally closed.

Parts list

Pos.	Qty	Denomination
1a	1	Plug
1	1	Pointed screw
2a	1	Air cylinder
2	1	Air cylinder
3 □	1	O-ring
4	1	Nut
5	1	Spring
6	1	Piston
10	1	Bottom piece
11 ♦	1	Lip seal
12	1	Hollow spindle
13 ♦	1	O-ring
14	1	Valve spindle
15	1	L-Valve house
	1	T-Valve house

Service kits

Denomination	25 mm
Service Kit for Actuator	
□ Service kit	9611-92-4001
Service Kit for Product wetted parts	
♦ Service kit, NBR	9611-92-4002
♦ Service kit, EPDM	9611-92-4003
♦ Service kit, FPM	9611-92-4004

Parts marked with □♦ are included in the service kits.

Recommended spare parts: Service kits.

900-427

8 Reed Type Double Signalling Unit for Valve LKAP

*It is important to observe the technical data during installation, operation and maintenance.
Inform the personnel about the technical data.
NO = Normally open.
NC = Normally closed.*

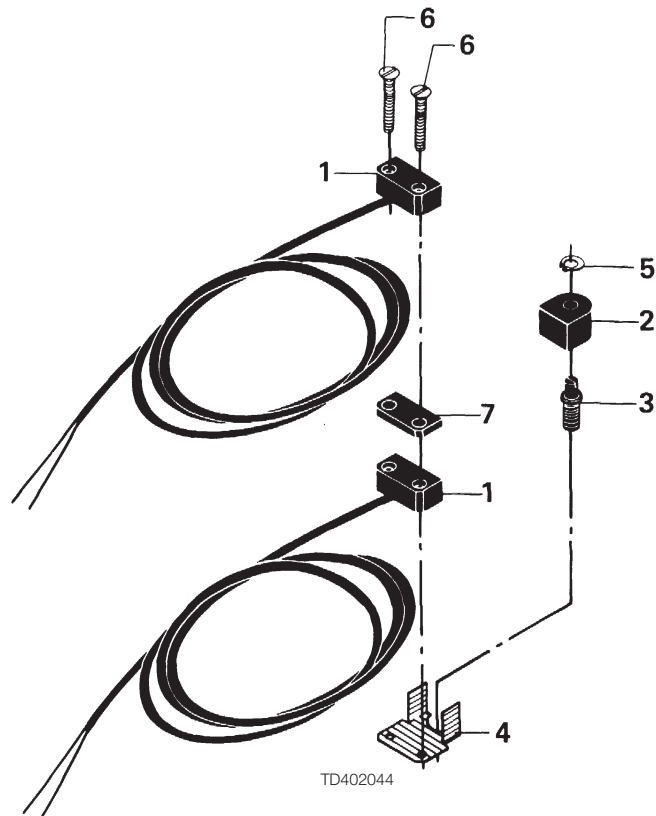

8 Reed Type Double Signalling Unit for Valve LKAP

It is important to observe the technical data during installation, operation and maintenance.

Inform the personnel about the technical data.

NO = Normally open.

NC = Normally closed.

Parts list

Pos.	Qty	Denomination
1	2	Single reed switch
2	1	Magnet for reed switch
3	1	Adjusting screw
4	1	Guide plate
5	1	Segerring
6	2	Screw
7	1	Distance plate (period 82.04-)

How to contact Alfa Laval

Contact details for all countries are continually updated on our website.

Please visit www.alfalaval.com to access the information direct.

© Alfa Laval Corporate AB

This document and its contents is owned by Alfa Laval Corporate AB and protected by laws governing intellectual property and thereto related rights. It is the responsibility of the user of this document to comply with all applicable intellectual property laws. Without limiting any rights related to this document, no part of this document may be copied, reproduced or transmitted in any form or by any means (electronic, mechanical, photocopying, recording, or otherwise), or for any purpose, without the expressed permission of Alfa Laval Corporate AB. Alfa Laval Corporate AB will enforce its rights related to this document to the fullest extent of the law, including the seeking of criminal prosecution.