

Pump construction

Close-coupled drivers are conventional drivers mounted directly to pumps frame. No base, coupling or guards are required for this mounting style.

Connections:

Universal flanges according to DIN PN16 - 40; ANSI B16.5 150# - 300# (2 stages vers.)

Flanges PN 64 - 100; ANSI B 16.5 600# (4 stages vers.)

Other on request.

Performance curves

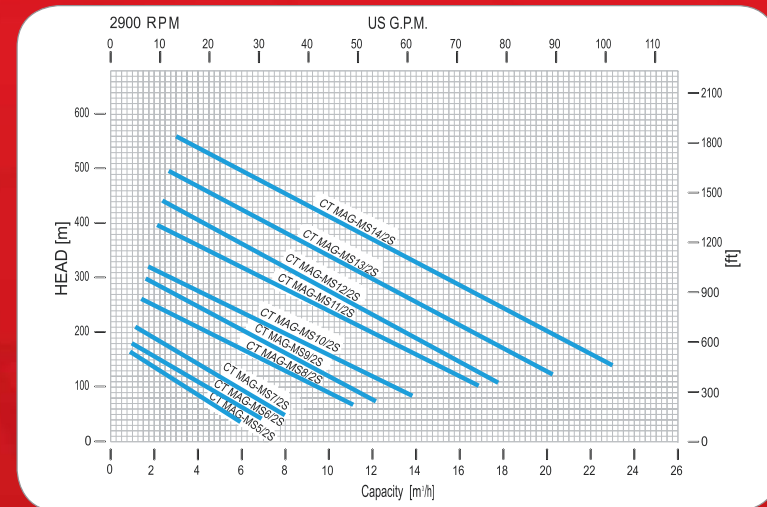

2 Stages

Operating Limits

- Max viscosity: 200 cSt
- Max system pressure: 50 bar (2 stages vers.) 150 bar (4 stages vers.) Higher pressure version available on request.
- Flow up: to 24 mc/h
- Head up: to 1000 m
- Temperature range: from -185 °F (-120 °C) to +662 °F (+350 °C)
- Electric motors: from 0,55 kW up to 132 kW
- Available ATEX II - / 2G cbk II C T2-T5

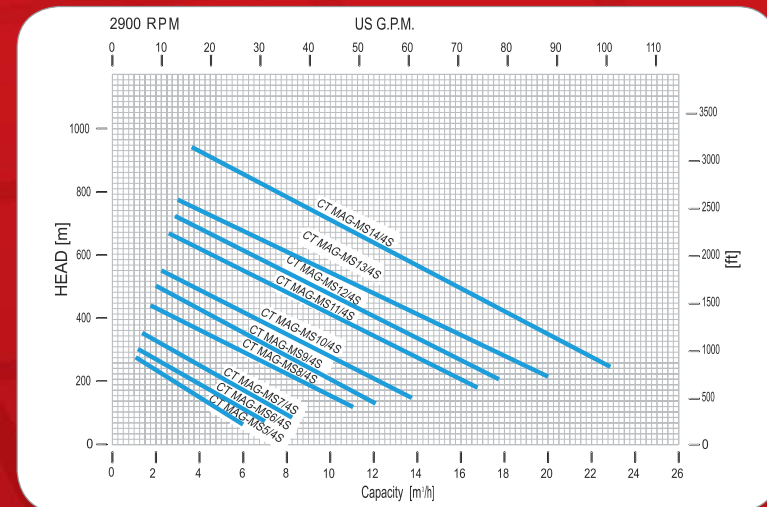

4 Stages

SPECIAL PERIPHERAL MULTISTAGE METALLIC MAG-DRIVE PUMPS



CT MAG-MS

Manufactured by:



A unit of
Mischiatti
GROUP

M PUMPS s.r.l. - Via dell'Artigianato, 120
45015 Corbola (Ro) - Italy - www.mpumps.it
Tel. +39 0426 346304 - Fax +39 0426 349126

For more information please contact:



ISO 14001:2004

273

Printed on 05-18-2012

CT MAG-MS Series

The hermetic sealless is the most convenient and safety solution for refineries, chemical and petrochemical industries, refrigeration and heat engineering, liquid gas plants, galvanic engineering, power stations and solar thermal fields, tank installations, pharmaceutical industries, fibers industries.

A wide range of pumps covers the different performances.

Low NPSH pumps (0,5m) are the perfect design for refrigeration market.



PUMP DETAILS

Epoxy primer and polyacrylic enamel water-based painting for the best quality resistance linked to the environmental respect.

The hydraulic barrier between two stages is made of a special intermediate bushing.

“Barrel” construction, with back inserted volute rings, to have the best hydraulic alignment and the longest wear rings life. Available in 2 or 4 stages.

Particular design of the hydraulic, with self balancing impeller to improve the wear ring life.

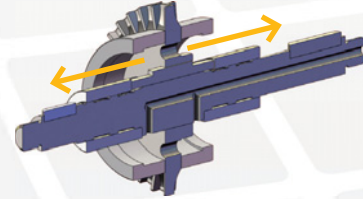

The range includes the construction with two and four stages, with or without centrifugal inducer to minimize the required NPSH up to 0,6 m, to allows the pumping of condenseds and generally all low available NPSH installations.

CF8M or WCB pump casing, cover & impellers High quality casting components.

Materials:
 - Hastelloy® C276
 - Incoloy® 825
 - Duplex
 - Others available on request

RWP QUICK CHANGE CARTRIDGE KIT to guarantee an easy and fast maintenance.

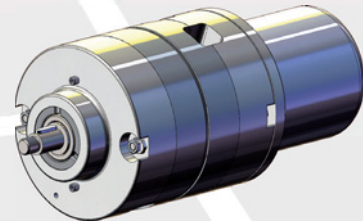

Drain plug (1/2" NPT) on standard construction

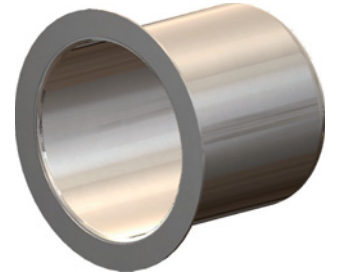
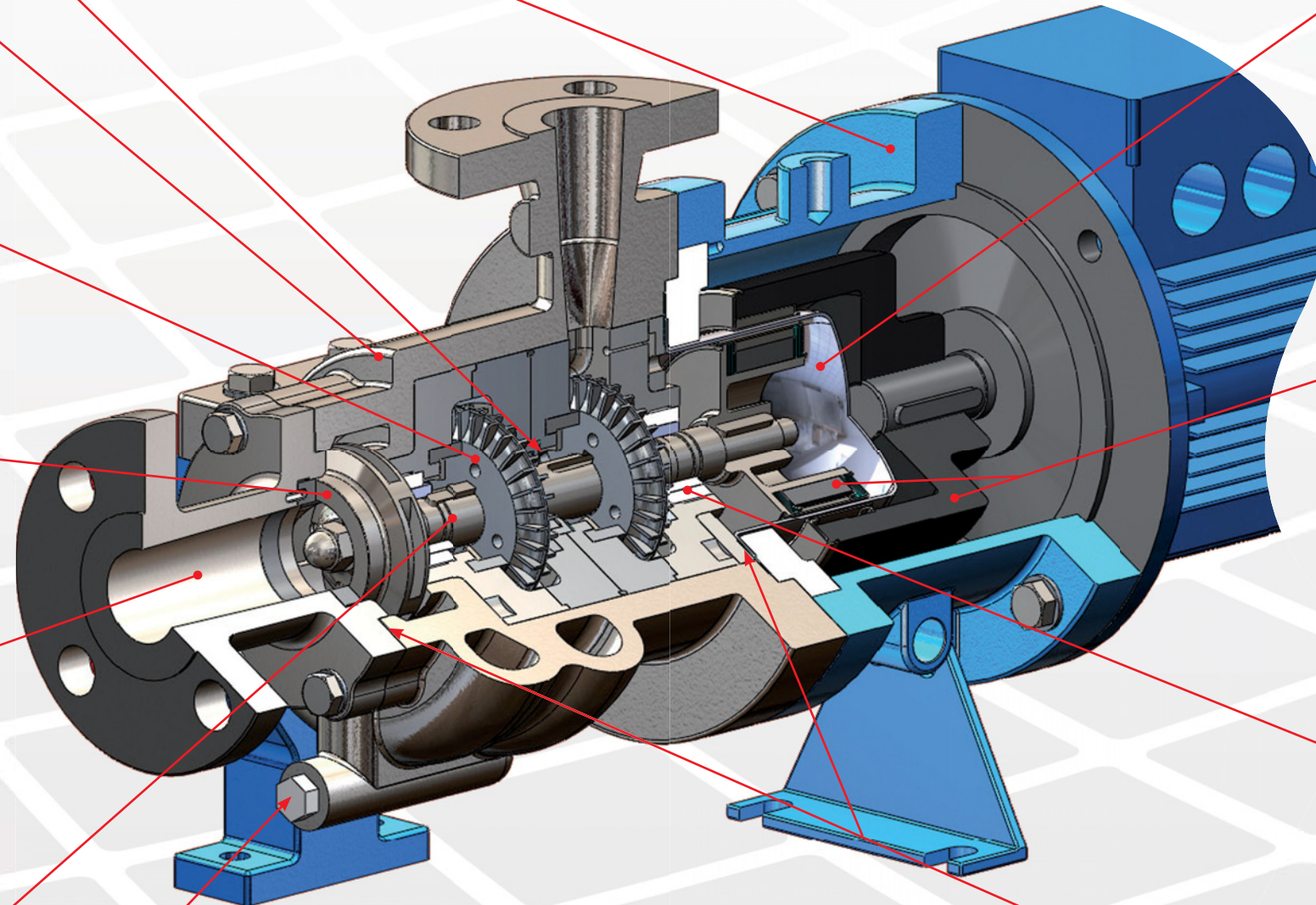

The rear shell is made of one single piece, no welding, ellipsoidal profile that has been studied to withstand higher pressures than the traditional one.
 Available two versions, AISI 316 the standard construction, and Hastelloy® C276 for high pressure version - providing a safe and efficient solution – system pressure max 150bar.
 Titanium Alloy is an upgrade when higher pressure ratings and increased efficiency are required.

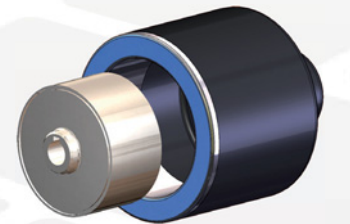

High power synchronous magnetic coupling designed by our Technical Office and with rare earth magnetic elements mechanically locked.

The high performance magnets can operate at liquid temperature of up to 662 °F (350 °C) without external cooling.

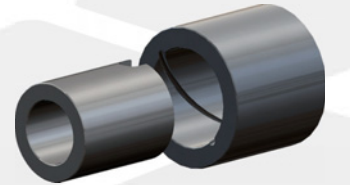

Field assembling of the product lubricated bearing arrangement does not require special tools.
 The Bearing materials are available in four different types to provide the best solution for each application: Silicon Carbide (SSIC), Tungsten Carbide (TC), Tungsten Carbide in combination with metallized Carbon to allow accidental dry running transitory and PTFEC/G or PEEK compound for any applications where Special Carbon cannot be used.
 The adoption of elastic rings reduces the sleeve bearing loads and the thrust bearing loads to the minimum, to guarantee many years of maintenance-free operation.

Sealing system with flat gaskets prevents product from leaking to the atmosphere – different materials available:

- Asbestos free
- PTFE
- Graphoil
- GYLON®
- Other on request