

Pump construction

Close-coupled drivers are conventional drivers mounted directly to pumps frame. No base, coupling or guards are required for this mounting style.

Universal Flanges Connections that meet DIN PN16 and ANSI 150#.

Performance curves

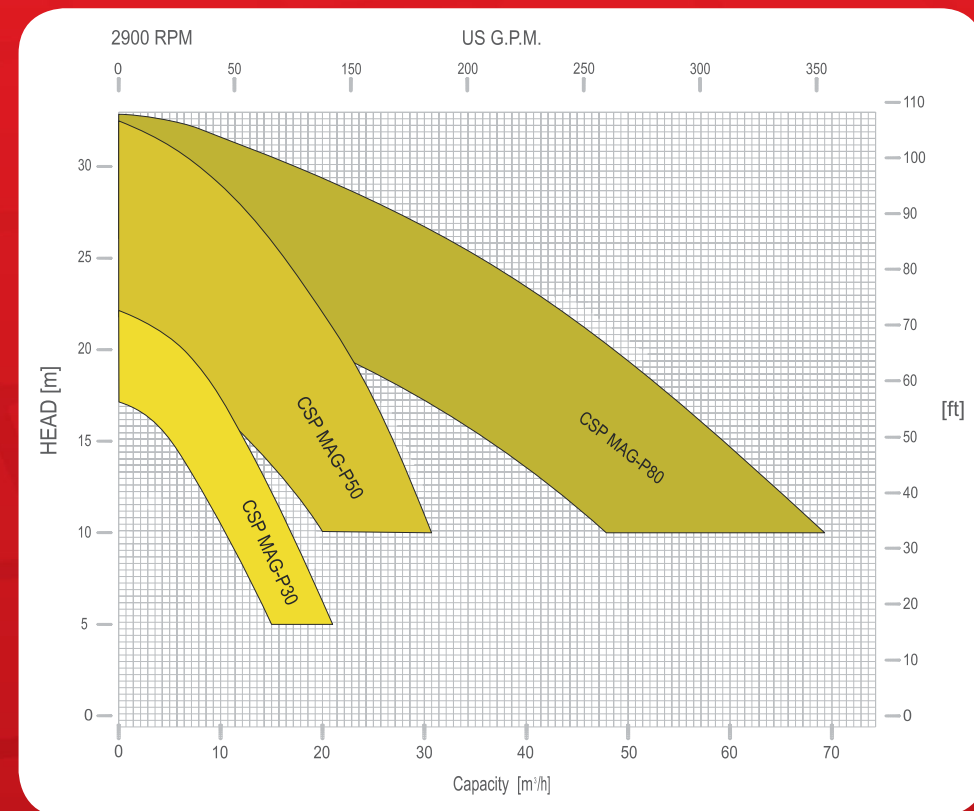

Operating Limits

- Max viscosity: 200 cSt
- Max system pressure: 5 bar
- Flow up: to 70 mc/h
Head up: to 32 m
- Temperature range: from 24 °F (-5 °C) to +194 °F (+90 °C)
- Electric motors: from 1,5 up to 9,2kW
- Self priming up: to 4 m
- Available ATEX II - / 3G cbk II C T5

HORIZONTAL, SELF-PRIMING SEALLESS PP AND PVDF CENTRIFUGAL PUMP WITH PERMANENT MAGNET DRIVE SYSTEM, NO MECHANICAL SEAL

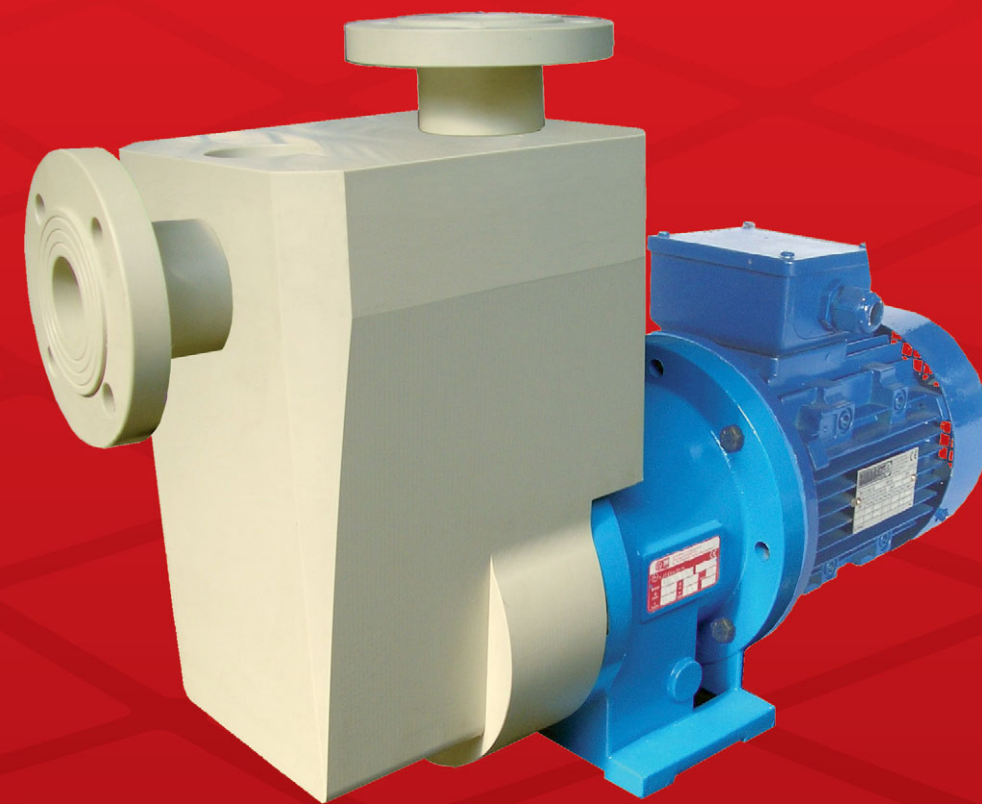

CSP MAG-P

Manufactured by:



A unit of
Mischiatti
GROUP

M PUMPS s.r.l. - Via dell'Artigianato, 120
45015 Corbola (Ro) - Italy - www.mpumps.it
Tel. +39 0426 346304 - Fax +39 0426 349126

For more information please contact:



CSP MAG-P Series

The separation of liquid chamber/atmosphere by means of an isolation shell is the best solution to pump aggressive chemical, high purity liquids and liquids difficult to seal.

The hermetical sealless is the best solution for the chemical and pharmaceutical industry.

A wide range of pumps covers the different performances.

The simple construction combined with high thickness guarantees a long life against the corrosion.



PUMP DETAILS

Pump casing shall be one single piece, achieved from solid bar, made of very high thickness PP and PVDF to have a good mechanical resistance and a guaranteed long life against the corrosion.

Epoxy primer and polyacrylic enamel water-based painting for the best quality resistance linked to the environmental respect.

RWP QUICK CHANGE CARTRIDGE KIT to guarantee an easy and fast maintenance, materials: PP and PVDF.

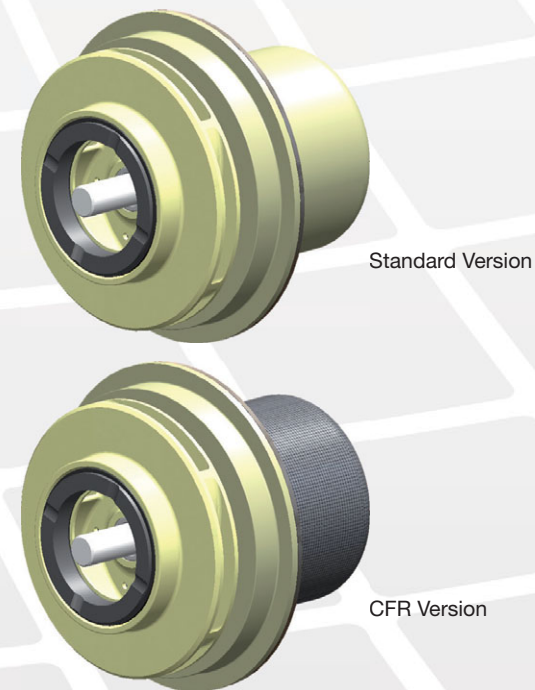

The sealing system with O-Rings prevents from leaking in the atmosphere – different materials available:

- EPDM
- VITON®
- FEP

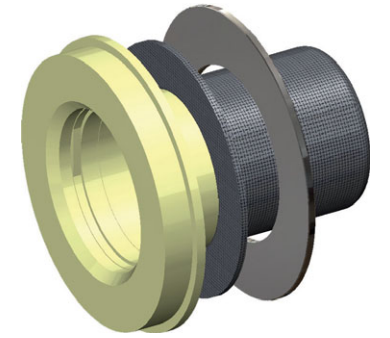
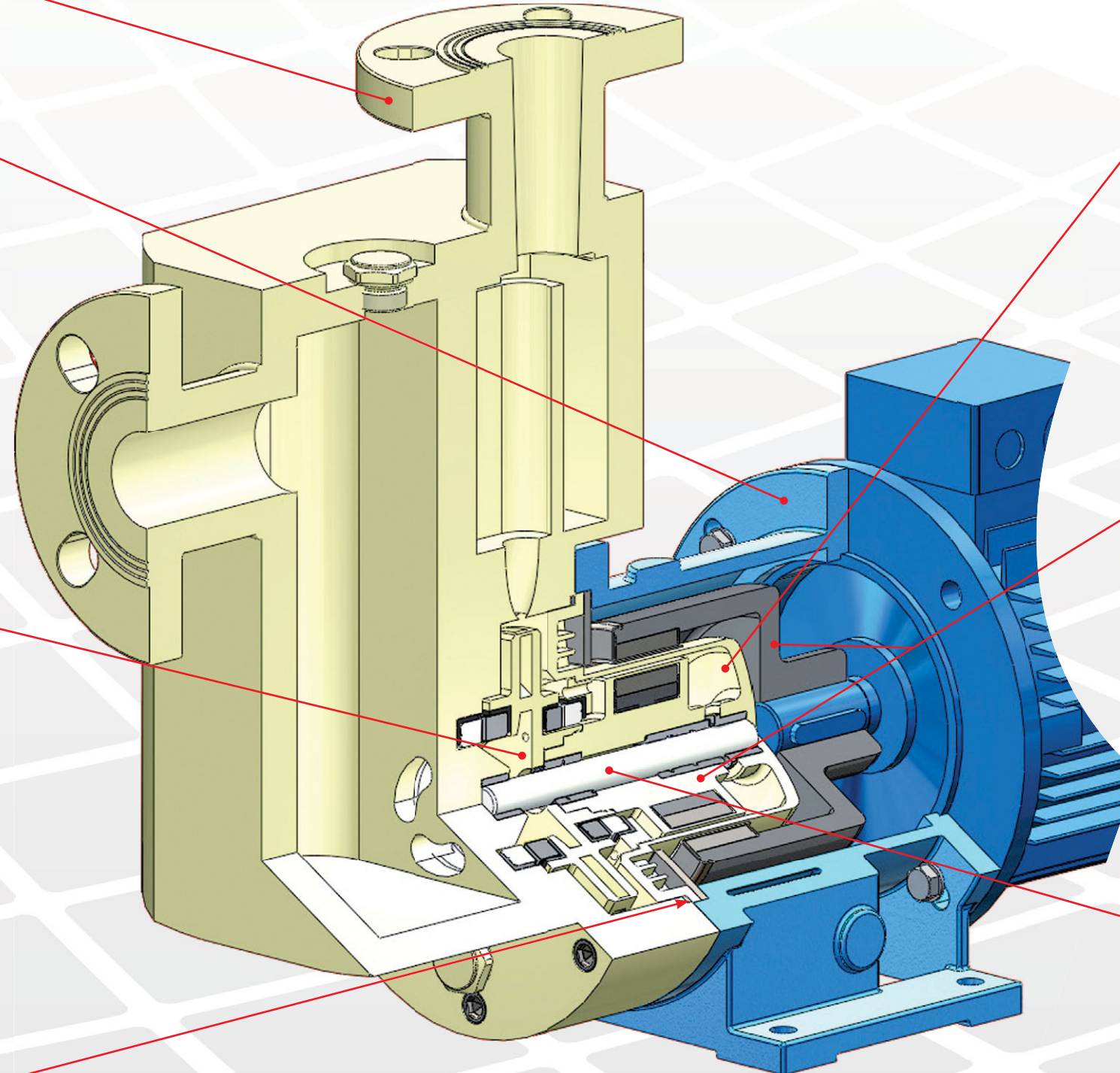

The rear shell is made of thermoplastic materials, as PP GFR or PVDF CFR with zero magnetic losses.

Outside rear shell cover ellipsoidal profile made of fiber reinforced composite material.

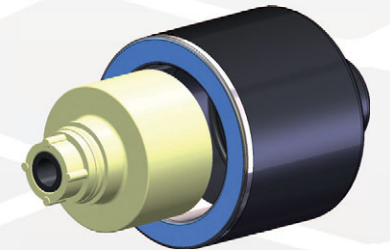

High power synchronous magnetic coupling designed by our Technical Office and with magnetic elements mechanically locked.

Rare earth guarantees the magnetic-balancing to avoid the thrust bearing wear and the heat generation.



Field assembling of the product lubricated bearing arrangement does not require special tools.

The Shaft / Bearing materials are available in three different configurations to provide the best solution for each application:

- PTFEC – ALLUMINA 99,7% (standard)
- CARBON – ALLUMINA 99,7%
- Silicon Carbide (SSIC) – Silicon Carbide (SSIC)

