

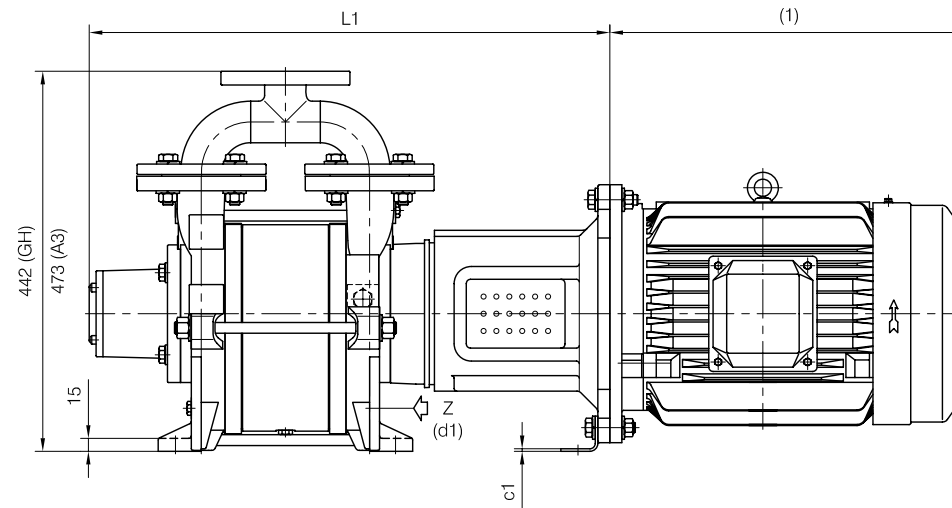

CLOSE-COUPLED construction

Versione **MONOBLOCCO**



d1 Connessione filettata G 1/2 - per ingresso alimentazione
 G 1/2 threaded connection - for liquid supply inlet

MOTORI ELETTRICI Electric Motors B5 - 4 poli / poles		
Grandezza Frame size IEC	Giri/min. RPM 1480 50Hz	
	kW	HP
112 M	4	5.5
132 S	5.5	7.5

(1) Dimensioni in funzione della marca del motore installato.
 (1) Dimensions depend on installed motor manufacturer.

POMPA TIPO Pump type	Motore Motor	Dimensioni costruttive Monoblocco / Close-coupled construction dimensions						Peso Weight
		L1	f3	G1	m3	m4	c1	
TRSC 40-150	112 M	584	356	187	44	191	4	86
	132 S	605	377	212	43	215	3	89

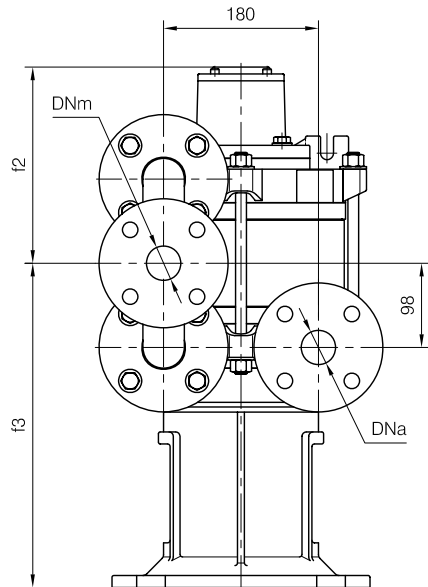
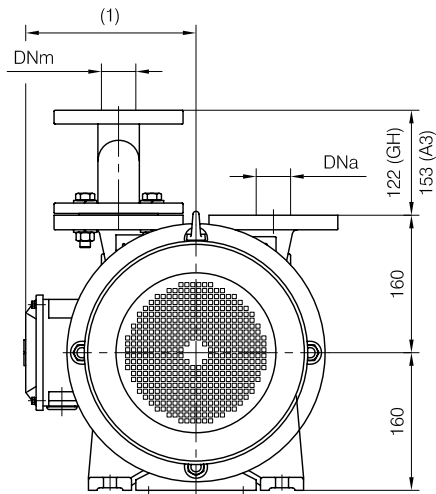

Disegno schematico. Dimensioni in mm con tolleranze secondo EN 735-1995.
 Pesì indicativi in Kg, riferiti a pompe in ghisa escluso motore, non impegnativi.
 Schematic drawing. Dimensions in mm with tolerances according to EN 735-1995 standards.
 Weights in Kgs, referred to pumps in cast iron without motor, not binding.