

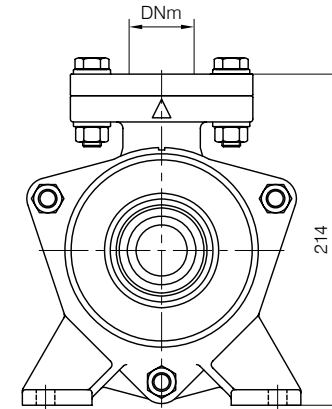

**BARESHAFT construction**

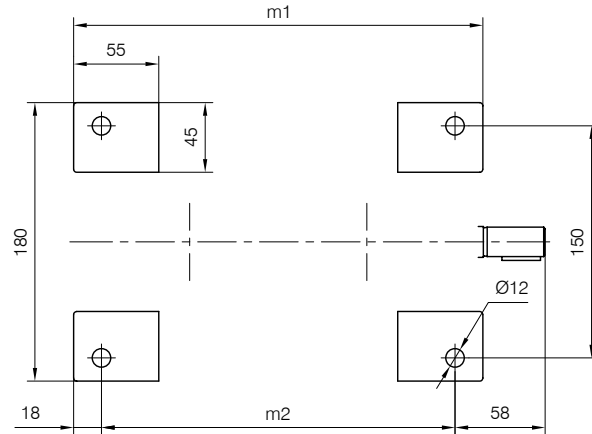

Versione ad **ASSE NUDO**

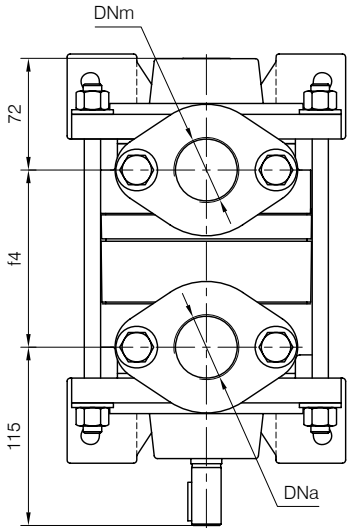
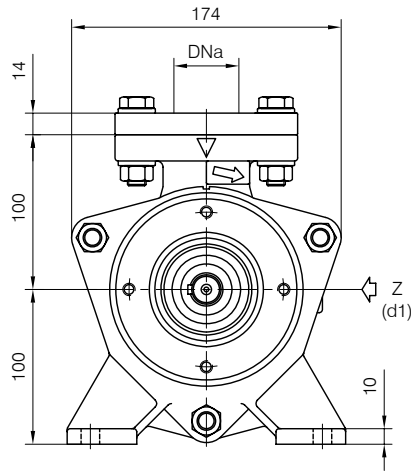
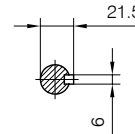
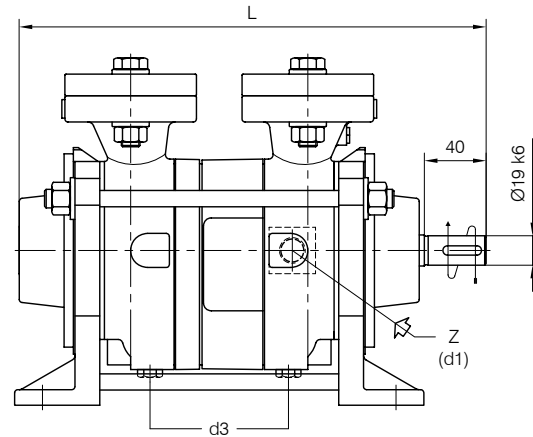

- d1 Connessione filettata G 3/8 - per ingresso alimentazione  
G 3/8 threaded connection - for liquid supply inlet
- d3 Attacco tappato G 1/4 - per scarico corpo pompa  
G 1/4 plugged connection - for pump casing drain

Nota / Note :

- Lt Quantità di acqua all'asse dell'albero in litri  
Water quantity at shaft axis in liters
- Mi Momento di Inerzia Max all'avviamento  
Max Moment of Inertia at start-up

POMPA TIPO Pump type	Dimensioni costruttive Construction dimensions						Peso Weight	Mi kgm <sup>2</sup>	Lt
	DNa	DNm	L	f4	m1	m2			
TRSC 32-20	G 1 1/4	G 1 1/4	302	114	265	229	19	0.003	0.9
TRSC 32-50	G 1 1/4	G 1 1/4	337	150	300	264	20	0.005	1

CONTROFLANGE FILETTATE: Dimensioni secondo UNI 2224 PN6  
 THREADED COMPANION FLANGES: Dimensions according to UNI 2224 NP6

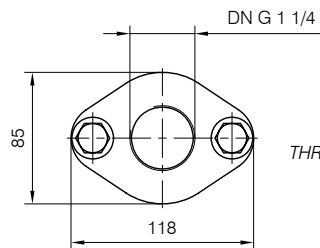

Disegno schematico. Dimensioni in mm con tolleranze secondo EN 735-1995.  
 Pesì indicativi in Kg, riferiti a pompe in ghisa escluso motore, non impegnativi.  
 Schematic drawing. Dimensions in mm with tolerances according to EN 735-1995 standards.  
 Weights in Kgs, referred to pumps in cast iron without motor, not binding.