

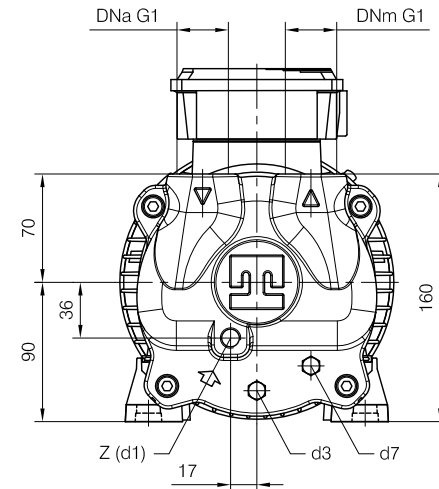

**CLOSE-COUPLED construction**



- d1 Connessione filettata G 1/4 - per ingresso alimentazione  
G 1/4 threaded connection - for liquid supply inlet
- d3 Attacco tappato G 1/8 - per scarico corpo pompa  
G 1/8 plugged connection - for pump casing drain
- d7 Attacco tappato G 1/8 - per valvola anticavitazione  
G 1/8 plugged connection - for anticavitation valve
- i4 Foro filettato per controllo rotazione albero motore  
Threaded hole for motor shaft rotation checking

MOTORI ELETTRICI / Electric Motors - IP 55 - 2 poli / poles				
Grandezza Frame size IEC	Giri/min. RPM 2900 50Hz V. 200-240/350-420		Giri/min. RPM 3500 60Hz V. 200-280/350-480	
	kW	HP	kW	HP
90 S-L	1.5	2	-	-
	2.2	3	2.2	3

Disegno schematico. Dimensioni in mm con tolleranze secondo EN 735-1995.  
 Pesi indicativi in Kg, riferiti a pompe in ghisa, non impegnativi.  
 Schematic drawing. Dimensions in mm with tolerances according to EN 735-1995 standards.  
 Weights in Kgs, referred to pumps in cast iron, not binding.

Versione **MONOBLOCCO**

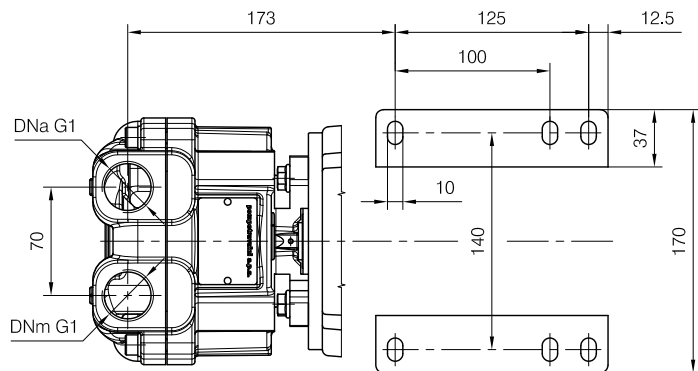
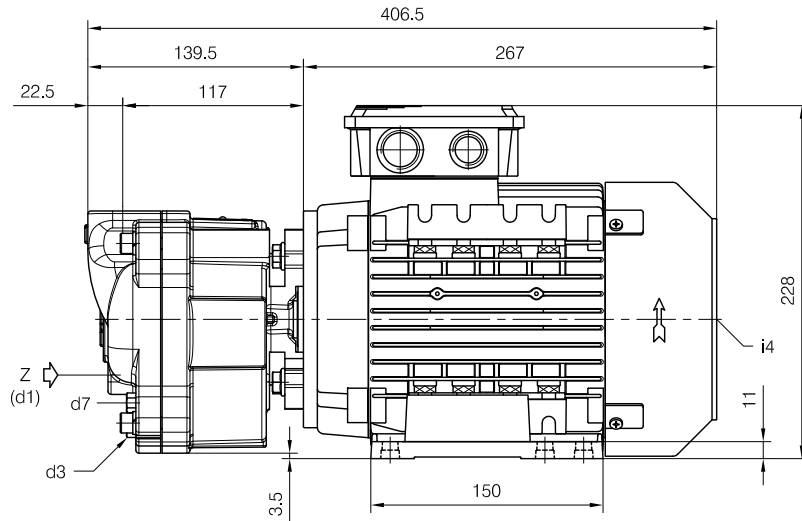

POMPA TIPO Pump type	Peso Weight	Mi kgm <sup>2</sup>	Lt
TRMX 257	25	0.006	0.4

Nota / Note :

- Lt Quantità di acqua all'asse dell'albero in litri  
Water quantity at shaft axis in liters
- Mi Momento di Inerzia Max all'avviamento  
Max Moment of Inertia at start-up