

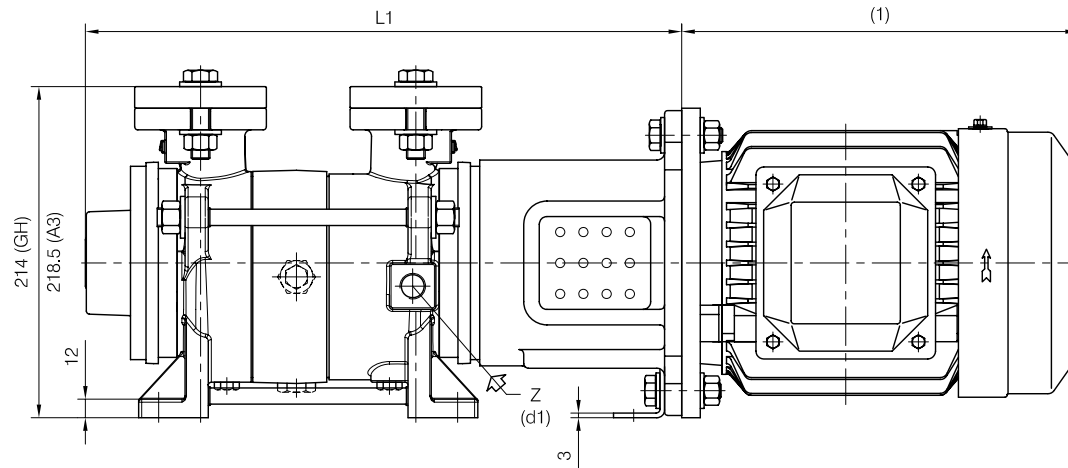

CLOSE-COUPLED construction



d1 Connessione filettata G 3/8 - per ingresso alimentazione
 G 3/8 threaded connection - for liquid supply inlet

MOTORI ELETTRICI Electric Motors B5 - 2 poli / poles		
Grandezza Frame size IEC	Giri/min. RPM 2900 50Hz	
	kW	HP
80	1.1	1.5
90 S	1.5	2
90 L	2.2	3

(1) Dimensioni in funzione della marca del motore installato.
 (1) Dimensions depend on installed motor manufacturer.

Dimensioni costruttive Monoblocco Close-coupled construction dimensions				
POMPA TIPO Pump type	Motore Motor	L1	f3	Peso Weight
TRHE 32-20	80	385	172	24
	90 S			
TRHE 32-45	90 S	435	172	27
	90 L			

Versione MONOBLOCCO

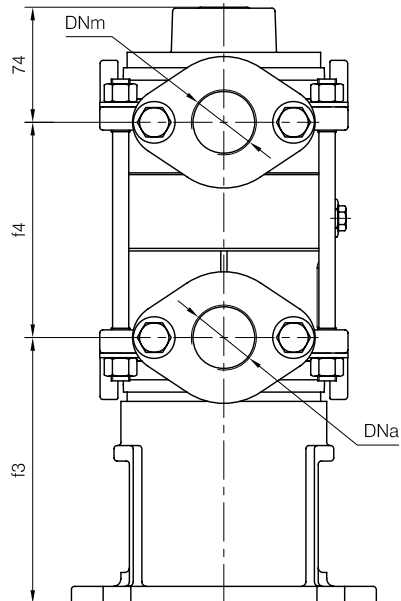
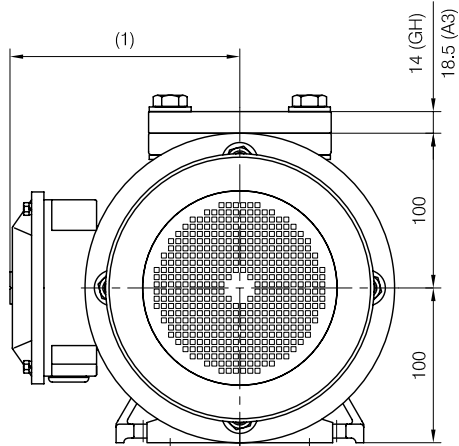

Disegno schematico. Dimensioni in mm con tolleranze secondo EN 735-1995.
 Pesì indicativi in Kg, riferiti a pompe in ghisa escluso motore, non impegnativi.
 Schematic drawing. Dimensions in mm with tolerances according to EN 735-1995 standards.
 Weights in Kgs, referred to pumps in cast iron without motor, not binding.