

DIMENSIONE D'INGOMBRO / Overall dimensions  
 POMPE PER VUOTO AD ANELLO DI LIQUIDO

Liquid ring vacuum pumps

SERIE / Series

**TRHE 32-60/C**

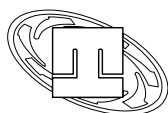

**pompetravaini** S.p.A.

CASTANO PRIMO (MILANO)

Versione **ACCOPIATA (BASE-GIUNTO)**  
**COUPLED construction (BASEPLATE-COUPLING)**

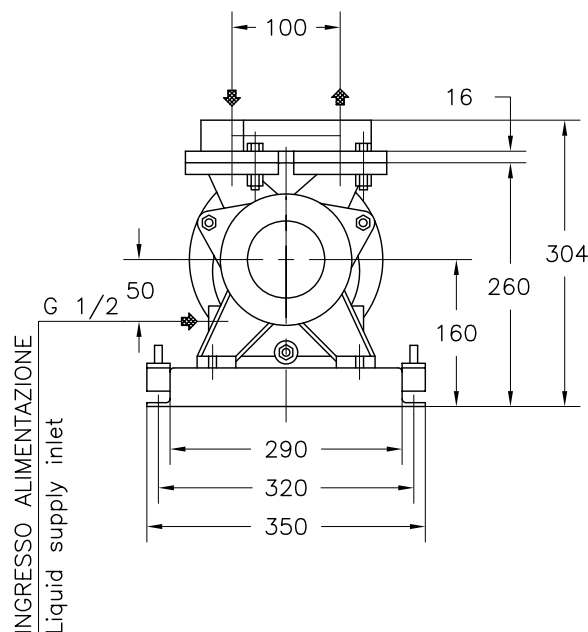
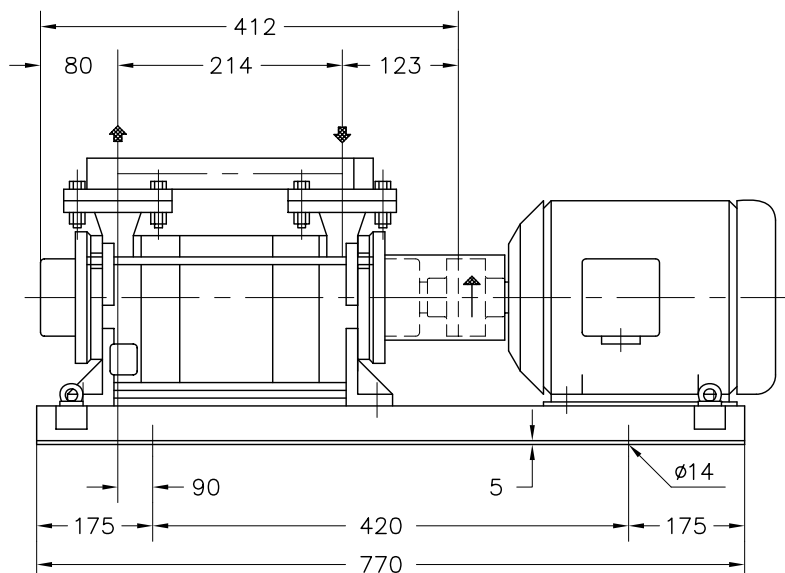

INGRESSO ALIMENTAZIONE  
 Liquid supply inlet

G 1/2

INGRESSO ALIMENTAZIONE  
 Liquid supply inlet

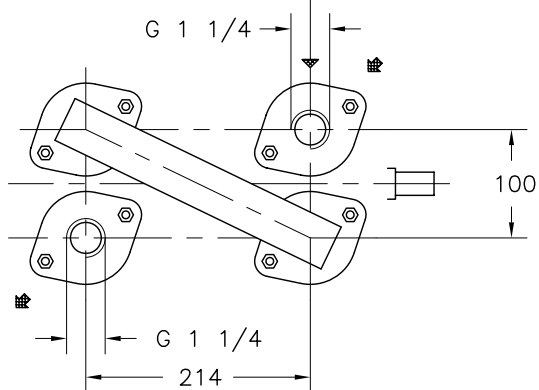

CONTROFLANGE FILETTATE  
 FLANGE SECONDO UNI 2224 PN 6  
 Threaded companion flanges  
 Flanges according to UNI 2224 NP 6

① PESO ESCLUSO MOTORE  
 Weight without motor

MOTORE A 2 POLI 2 Poles Motor UNEL-MEC-B3		BASE Base-plate N°	PESO Weight ①
TIPO/Type	KW		
90 L	2,2	901	43
100 LA	3		
112 M	4		

DISEGNO SCHEMATICO - DIMENSIONI IN MM. CON TOLLERANZE SECONDO EN 735-1995 E PESI IN KG. NON IMPEGNATIVI  
 Schematic drawing - Dimensions in mm. with tolerances according to EN 735-1995 and weights in kgs. not binding

RIF.-Ref.: E.Z./C.T. DOCUMENTO N. - Document no.: 6516.5L3.2001.04.01

DATA -Date: 07-2009 SOSTITUISCE DOC. - Replaces Doc. (ITEM): 6516.5L3.201.03 (-)

ITEM n° D00068R