

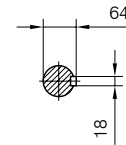

**BARESHAFT construction**

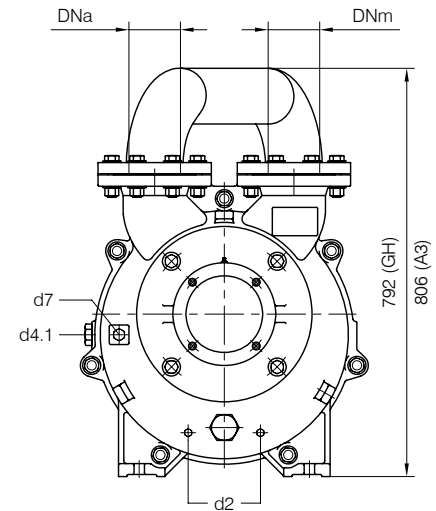

- d1 Connessione filettata G 1 1/2 - per ingresso alimentazione  
G 1 1/2 threaded connection - for liquid supply inlet
- d2 Attacco tappato G 1/4 - per scarico corpo pompa  
G 1/4 plugged connection - for pump casing drain
- d3 Attacco tappato G 3/8 - per scarico corpo pompa  
G 3/8 plugged connection - for pump casing drain
- d4 Attacco tappato G 1/4 - per manovuotometro  
G 1/4 plugged connection - for manovacuum gauge
- d4.1 Attacco tappato G 1 - connessione ausiliaria per valvola automatica di drenaggio  
G 1 plugged connection - auxiliary connection for automatic draining valve
- d5 Attacco tappato G 1 1/4 - connessione ausiliaria  
G 1 1/4 plugged connection - auxiliary connection
- d6 Connessione ingrassatore - per lubrificazione cuscinetti tipo 6314  
Greaser connection - for ball bearings type 6314 lubrication
- d7 Attacco tappato G 1/2 - per valvola anticavitazione  
G 1/2 plugged connection - for anticavitation valve

**Versione ad ASSE NUDO**

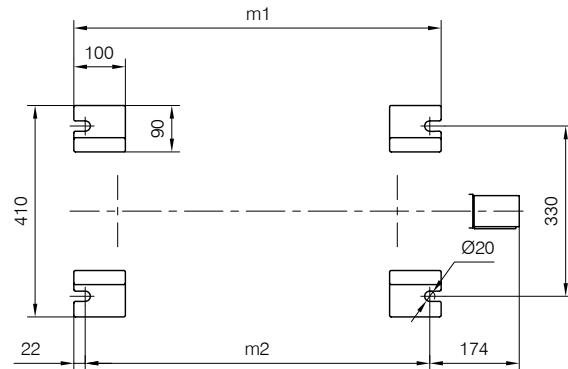
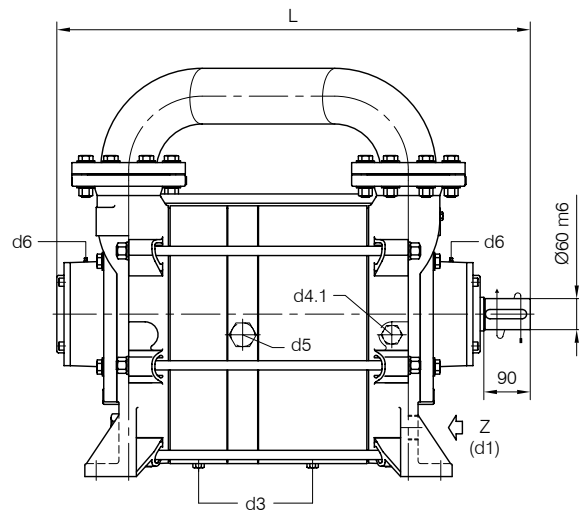

Nota / Note :

- Lt Quantità di acqua all'asse dell'albero in litri  
Water quantity at shaft axis in liters
- Mi Momento di Inerzia Max all'avviamento  
Max Moment of Inertia at start-up
- (GH) Pompa in ghisa e sue derivate  
Cast iron pumps and derivatives
- (A3) Pompa in acciaio inox e sue derivate  
Stainless steel pumps and derivatives

FLANGE: Dimensioni secondo UNI 2223 PN10  
 FLANGES: Dimensions according to UNI 2223 NP10

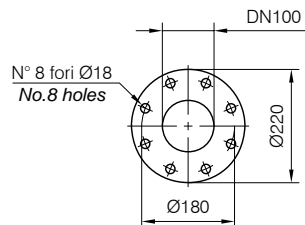
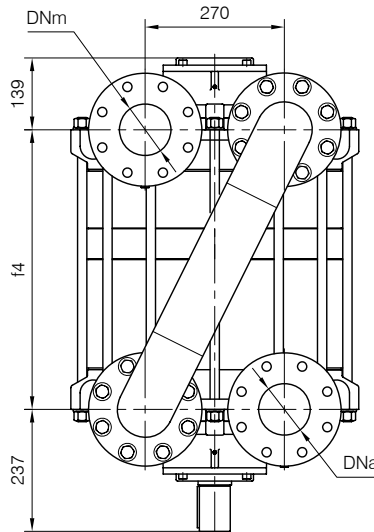
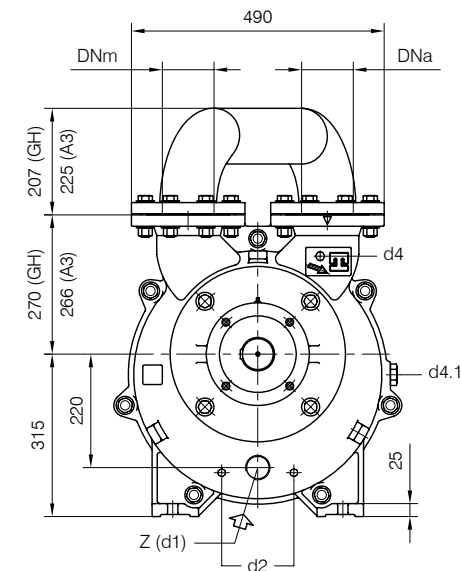

POMPA TIPO Pump type	Dimensioni costruttive Construction dimensions						Peso Weight	Mi kgm <sup>2</sup>	Lt
	DNa	DNm	L	f4	m1	m2			
TRHE 100-870	100	100	918	542	712	668	412	1.5	35
TRHE 100-1260	100	100	1068	692	862	818	485	2.2	46
TRHE 100-1600	100	100	1168	792	962	918	518	2.6	52

Disegno schematico. Dimensioni in mm con tolleranze secondo EN 735-1995.  
 Pesi indicativi in Kg, riferiti a pompe in ghisa escluso motore, non impegnativi.  
 Schematic drawing. Dimensions in mm with tolerances according to EN 735-1995 standards.  
 Weights in Kgs, referred to pumps in cast iron without motor, not binding.