

DIMENSIONE D'INGOMBRO / Overall dimensions
 POMPE PER VUOTO AD ANELLO DI LIQUIDO

Liquid ring vacuum pumps

SERIE / Series

TRHC 40-110/C

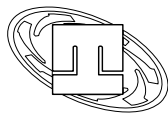

pompetravaini S.p.A.

CASTANO PRIMO (MILANO)

Versione ad **ACCOPIATA (BASE-GIUNTO)**
COUPLED construction (BASEPLATE-COUPLING)

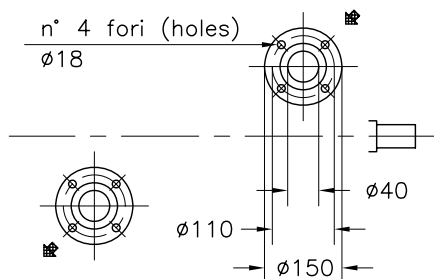
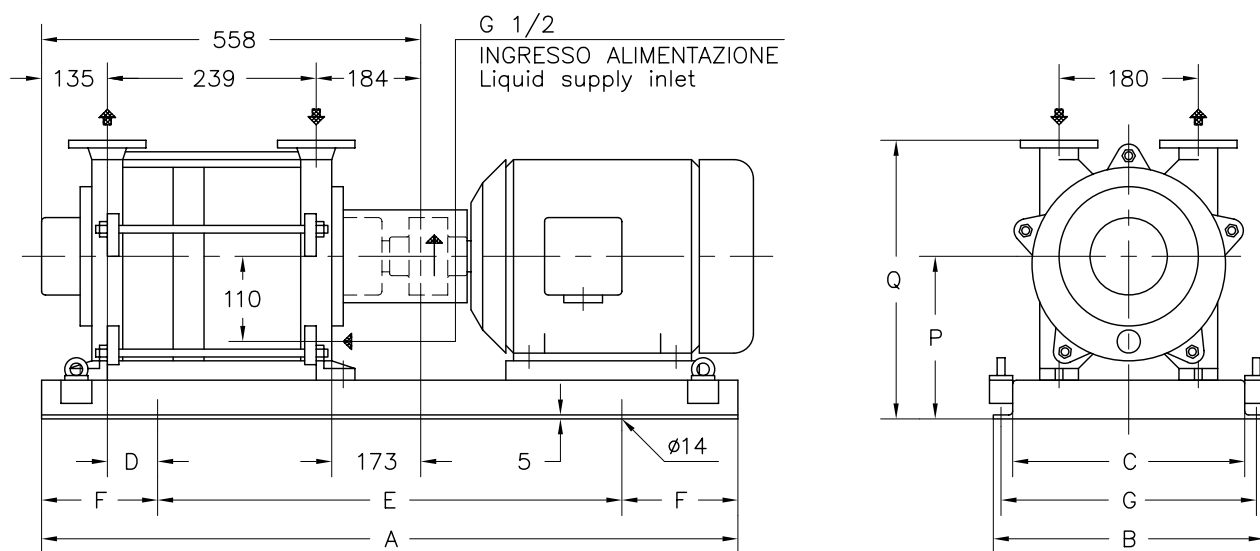

FLANGE SECONDO UNI 2223 PN 10
 Flanges according to UNI 2223 NP 10

MOTORE A 4 POLI 4 Poles Motor UNEL-MEC-B3		BASE Base-plate N°	POMPA Pump										PESO Weight
TIPO/Type	KW		A	B	C	D	E	F	G	P	Q	①	
112 M	4	901	770	350	290	125	420	175	320	220	380	92	
132 SA	5,5	900	960	370	310	70	600	180	340	225	385	105	

① PESO ESCLUSO MOTORE
 Weight without motor

DISEGNO SCHEMATICO - DIMENSIONI IN MM. CON TOLLERANZE SECONDO EN 735-1995 E PESI IN KG. NON IMPEGNATIVI
 Schematic drawing - Dimensions in mm. with tolerances according to EN 735-1995 and weights in kgs. not binding

RIF.-Ref.: E.Z./C.T. DOCUMENTO N. - Document no.: 6521.3L3.2001.01.01

DATA -Date: 07-2009 SOSTITUISCE DOC. - Replaces Doc. (ITEM): 6531.3L3.201.01 (-)

ITEM n° D00088R