



INDUSTRY

ROTAN® - Geared to individual solutions

PROVEN TECHNOLOGY

**DESMI**

# INDUSTRY

Key factors in all areas of the process industry are production reliability, productivity and performance. These are precisely the areas addressed by the DESMI range of products, systems and services. Value-added liquid transport solutions for local and global companies are our scope of supply.



INTRODUCTION	4
MODELS	6
SPECIAL FEATURES	12
ADDITIONAL FEATURE	14
SELECTION OF PUMP SIZE	15
ITEM REFERENCES AND DESCRIPTIONS	16
PUMP SPECIFICATIONS	18
CONFIGURATIONS / OPTIONS	19

## DESMI, formerly known as A/S De Smithske, was founded in 1834

Over the years the product range has developed concurrently with the market requirements. From foundry products such as stoves and church bells to steam engines and pumping plants and over to steel constructions like bridges, tank installations, and cranes.

Today DESMI's activities are concentrated on pumps, pumping systems, environmental products and service within these areas. The many years of experience within the iron industry have resulted in a strong foundation and a well established position in the global market.

DESMI is owned by a group of DESMI executives.

DESMI pumps are marketed and distributed by subsidiaries, sales agencies, and distributors in more than 40 countries. For more detailed information, please visit our website: [www.desmi.com](http://www.desmi.com).

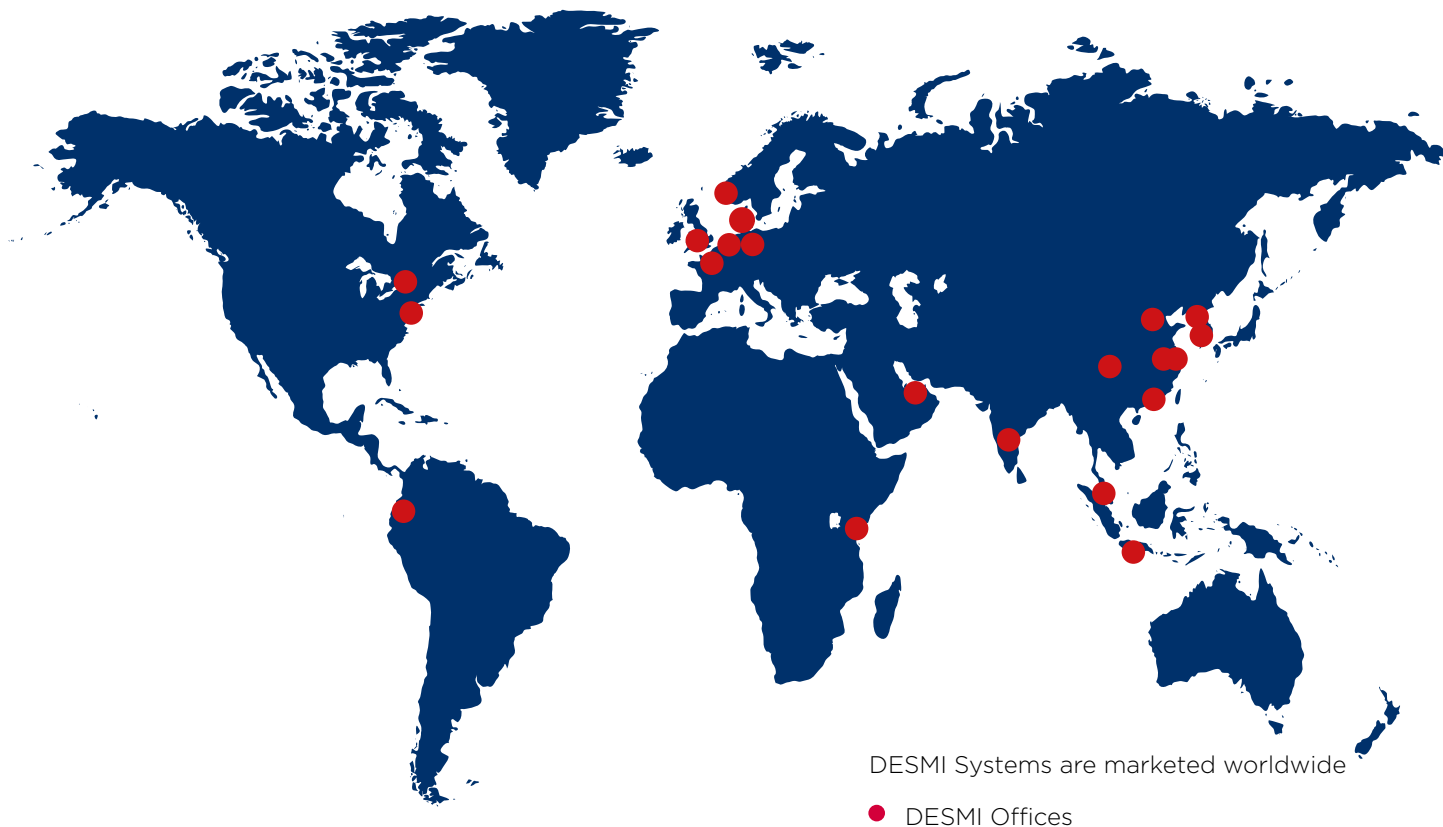

# ROTAN®, One of the world's Leading pumps within Internal Gear Pumps

The internal gear pump principle was developed in 1915 by a Danish American.

In 1921, he licensed a Danish company to manufacture the pumps, which have been continuously marketed worldwide under the ROTAN® name. The unique, modular concept of ROTAN® pumps is generally recognized as the most advanced internal gear pump design available today.

The ROTAN® internal gear pump provides favourable flow conditions, as the direction of the liquid flow is only changed slightly through the pump.

## Method of operation

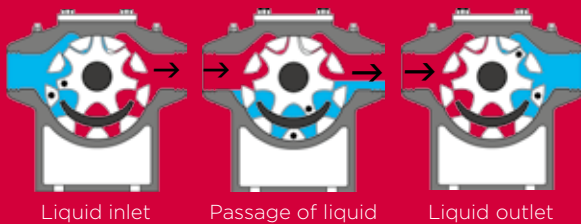

This means that superior self-priming capability and gentle liquid handling are achieved, and also that highly viscous liquids can be pumped. ROTAN® pumps offer the following additional advantages:

- Pumping in either direction
- Easy maintenance and inspection based on the modular design
- Sturdy and uncomplicated construction with only two rotating parts and one shaft seal
- Comprehensive choice of configurations available as standard
- Genuine back pull-out design
- End clearance axial adjustment



CE 

All ROTAN® pumps are hydrostatically tested.

ROTAN® pumps can be supplied in accordance with the ATEX Directive for use in potentially explosive environments.

The ROTAN® pumps are certified by Physikalisch-Technische Bundesanstalt PTB, Postfach 33 45, 38023 Braunschweig, registration number 03 ATEX D052.

It is DESMI's policy to offer customized solutions developed in co-operation with worldwide leading companies and to follow-up by first class after-sales service.

## ROTAN® GP – General Purpose Pumps

Pumps in cast iron, for clean, non-abrasive liquids. The simple and compact construction makes it a low-cost pump, often used in modified versions by OEM customers. A close-coupled OEM model is also available

GP pumps are designed for use with IEC or NEMA flange motors. Available with 90° angular configuration.

Pumping of:

- Clean oil
- Glycol
- Vegetable oil
- Solvents
- Lube oil
- Waste oil
- Fish oil

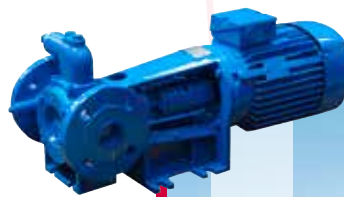

Capacity Range	Up to 50 m <sup>3</sup> /h / 220 gpm
Speed	Up to 1750 rpm
Differential Pressure	Up to 16 bar / 232 psi
Suction Lift	Up to 0,5 / 7.25 psi bar vacuum while priming Up to 0,8 bar / 11.6 psi vacuum while pumping
Viscosity Range	Up to 7500 cSt
Temperature	Up to 150°C / 302°F

## ROTAN® HD – Heavy Duty Pumps

Pumps in cast iron, for a wide range of viscous, non-corrosive liquids. HD pumps are specifically designed for difficult applications and those involving high viscosity liquids.

HD pumps are known by their sturdy and simple construction. Available with 90° angular configuration.

Pumping of:

- Oil
- Asphalt
- Chocolate
- Paint/Lacquer
- Molasses
- Soap
- Additives
- Polyol
- Viscose
- Sulphate soap
- Maltose
- Grease
- Pitch
- Base oil
- Bitumen
- Polyester



Capacity Range	Up to 250 m <sup>3</sup> /h / 1100 gpm
Speed	Up to 1750 rpm
Differential Pressure	Up to 16 bar / 232 psi
Suction Lift	Up to 0,5 bar / 7.25 psi vacuum while priming Up to 0,8 bar / 11.6 psi vacuum while pumping
Viscosity Range	Up to 250,000 cSt
Temperature	Up to 250°C / 482°F

# ROTAN® PD – Petrochemical Duty Pumps

PD pumps are designed for refinery and petrochemical applications, all pressure-containing components are in carbon steel. Design pressure according to ANSI 300 Lbs or Pn40.

PD pumps meet API 676 standards with only a few exceptions.

Available with 90° angular configurations.

Pumping of:

- Fuel
- Oil
- Gasoline
- Lube oil
- Grease
- Other hydrocarbon based fluids
- Additives
- Bitumen
- Polystyrene
- Wax



Capacity Range	Up to 170 m <sup>3</sup> /h / 748 gpm
Speed	Up to 1750 rpm
Differential Pressure	Up to 16 bar / 232 psi
Suction Lift	Up to 0,5 bar / 7.25 psi vacuum while priming Up to 0,8 bar / 11.6 psi vacuum while pumping
Viscosity Range	Up to 250,000 cSt
Temperature	Up to 250°C / 482°F

# ROTAN® CD – Chemical Duty Pumps

Pumps in stainless steel, designed to handle corrosive liquids.

CD pumps are designed for handling corrosive liquids, primarily found in the chemical processing, food and pharmaceutical industries.

Available with 90° angular configuration.

Pumping of:

- Organic acid
- Fatty acid
- Alkali
- Caustic soda
- Polymer solutions
- Soap
- Shampoo
- Animal fat
- Vegetable fat
- Chocolate
- Other special fluids
- Resin
- Paint
- Rosin



Capacity Range	Up to 170 m <sup>3</sup> /h / 748 gpm
Speed	Up to 1750 rpm
Differential Pressure	Up to 16 bar / 232 psi
Suction Lift	Up to 0,5 bar / 7.25 psi vacuum while priming Up to 0,8 bar / 11.6 psi vacuum while pumping
Viscosity Range	Up to 250,000 cSt
Temperature	Up to 250°C / 482°F

# ROTAN® ED – Environmental Duty Pumps

Magnetically coupled pumps for ultimate protection against leakage.

As only minimal maintenance is necessary, ED pumps will be a very economical solution compared with traditionally sealed pumps, especially where the application requires the use of double mechanical shaft seals.

Often these applications are very different, resulting in the seals and support system requiring regular attention and/or replacement. Thus, the life cycle costs for ED pumps are generally much lower than for pumps using two seals.

Available with 90° angular configuration.

## Common Applications:

Where no leakage, liquid or gaseous, is allowed.

Pumping of:

- Isocyanate
- Solvents
- Hazardous organic liquids
- Printing ink
- Resin
- Pitch
- Alkyd resin
- Soyabean oil
- Linseed oil
- Monomers
- Polyol
- Corn syrup



Materials	Cast iron, carbon steel or stainless steel
Capacity Range	Up to 90 m <sup>3</sup> /h / 396 gpm
Speed	Up to 1750 rpm
Differential Pressure	Up to 16 bar / 232 psi
Suction Lift	Up to 0,5 bar / 7.25 psi vacuum while priming Up to 0,8 bar / 11.6 psi vacuum while pumping
Viscosity Range	Up to 10,000 cSt
Temperature	Up to 250°C / 482°F

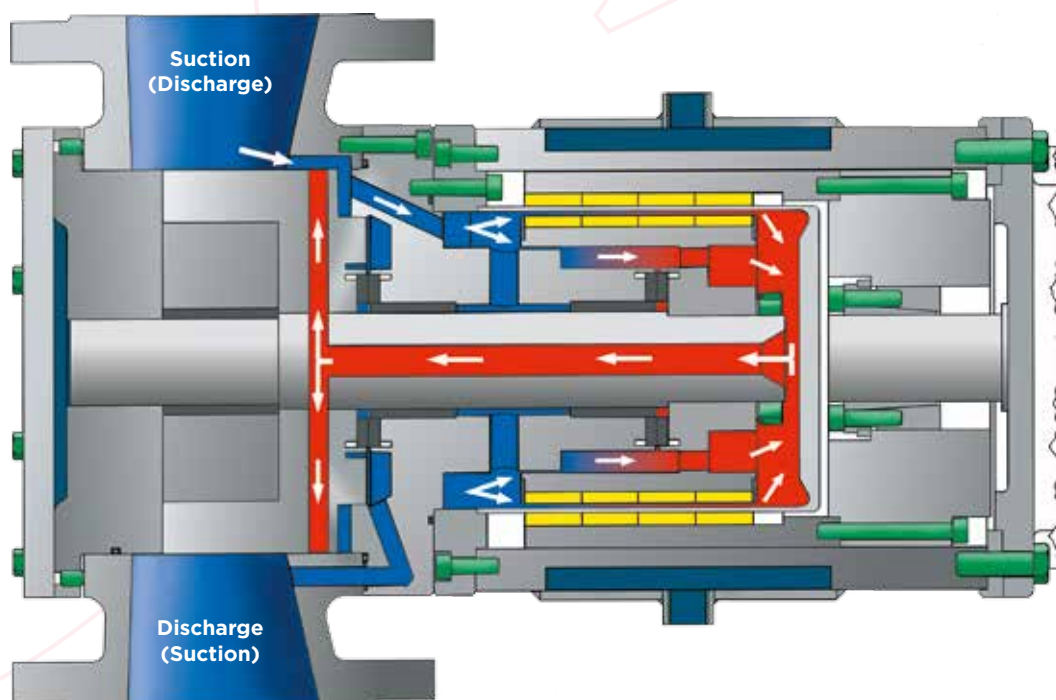



One of the distinguished features of the ROTAN® ED range is that the pumped medium is hermetically contained in the system since the magnetic coupling eliminates the need for a shaft and mechanical seal, which could allow gaseous exchange between the pumped medium and the atmosphere.

Unlike centrifugal pumps, the ROTAN® ED pump offers gentle liquid handling and a high priming vacuum as well as the pumping of highly viscous liquids.

- Dynamic axial balancing system, minimizing axial loads, saving energy and increasing life (see picture on the left side)
- Patented cooling system, based on an integral pump, eliminating the need for external cooling (see picture on the left side)
- Maximum protection against leakage by increased safety provided by a completely enclosed magnetic coupling housing

- Optimal for outdoor installation, the completely enclosed magnetic coupling housing protects the external magnets from contact with the surrounding atmosphere
- Large choice of slide bearing materials available as standard, e.g. cast iron, bronze, carbon and tungsten carbide
- Standard magnet material is neodymium-iron-boron.
- Optional samarium cobalt permanent magnets permit operating temperatures up to 250°C
- Pumping in either direction
- External heating jackets for both front cover and magnetic coupling housing available as standard optional features
- Genuine back-pullout design
- Standard as close-coupled, optional with bare shaft end
- Both internal and external canister protection

---

The ROTAN® pump is provided with a patented principle of circulation of the pump medium around the magnetic coupling. Simple “centrifugal pump” shaped channels in the shaft/rotor ensure continual replacement of the liquid in the magnetic coupling which has been heated by friction and re-circulation. This also ensures efficient lubrication and heat transfer from the slide bearings.

The ROTAN® ED pump can be used where leakage would be costly, e.g. highly refined, expensive chemicals, or where long overhaul intervals are required. This reduces maintenance labour costs and loss of process time, where atmospheric air would harm the pumped medium.

Typical construction materials of the ED pump are cast iron, stainless steel or carbon steel. For stan-

dard applications the ED pump is usually delivered with slide bearings in bronze/steel. As alternative the pump can be delivered with bearings in cast iron/steel for light applications, in carbon/steel for media with poor lubricating properties or in tungsten carbide/tungsten carbide for abrasive media, particularly with low wear rate.

The magnetic coupling is provided with the number of magnets required for the power to be transmitted. The material is neodymium-iron-boron for operating temperatures up to 150°C or samarium-cobalt for operating temperatures higher than 150°C. Both magnetic materials are rare earth types which can be magnetized approx. 10 times more than iron.

---

The ROTAN® ED pump is designed as a monobloc unit, i.e. directly coupled with an IEC-motor, gearmotor or gearbox with an IEC-motor. As an alternative, a free shaft end unit can be assembled with a drive unit by means of a flexible coupling.

Reversible pumping capability allows changing flow direction of the pump simply by reversing the motor direction. The ED pump is increasingly cost effective in the most severe operation conditions including high pressures, high viscosities, high temperatures, corrosive and high flow applications.

Abrasion resistant shafts, bearings, and thrust washers are available when abrasive materials are to be pumped. The ROTAN® ED pump is proven in most difficult applications including coal tar slurries and filled polyols. Other magnetically driven pumps with balanced rotor designs allow the rotor to make contact with balance plates and are not designed for abrasive service.

External jacketing of the pump head and magnet area are standard options when material in the pump and magnet area requires heat transfer.





Geared to individual solutions  
- *proven technology*

# Special Features

## DESMI Vertical Gear Pump

To comply with increasing requirements for pumps in areas with no space for normal horizontal configuration, a new vertical design has been developed. Vertical design advantages:

- Easier servicing - dismantling the whole rear end incl. bracket, rear cover, rotor and shaft without moving neither pump casing nor motor/gear.
- Enough space for dismantling the rear cover, idler and idler pin, which makes it possible to disassemble the pump completely without removing the pump casing from the pipe system.
- GP/HD/CD/PD pumps are available in vertical design.



## Cooling Industry

To meet the increasing demands the pumps have been developed over the years in close co-operation with various important customers within the refrigeration industry to whom DESMI ROTAN® has supplied pumps since 1979.

The demand to phase out the use of chlorine-containing refrigerants causing damage to the ozone layer has lead to new refrigerants and lubricating oils which make special calls on the pumps, such as:

- The materials in the refrigerating installation, particularly the elastomers, must be compatible with the new refrigerants and lubes. Mechanical seals and static sealing must be able to withstand vacuum suction as more of the new refrigerants are hygroscopic, i.e. absorbing water from the air.
- This makes it necessary to evacuate aqueous vapour, if any, from the installation before filling up with oil.
- New refrigerants often demand higher design pressure



## Chocolate Pump

A speciality within the ROTAN® range is the ROTAN® chocolate pump for pumping cocoa mass and chocolate. This special configuration has been utilized in the HD and CD ranges with all its advantages:

- Configuration with special clearances between the fixed and the rotating parts to protect the chocolate from excessive temperatures.
- Casing available as inline (standard) or 90° angular configuration (BCHD).
- Specially designed externally lubricated main bearing.

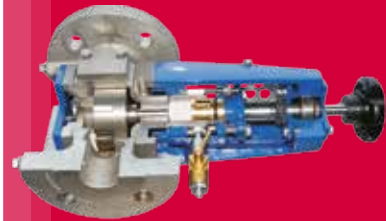

## Electrical Heating

ROTAN® has for many years supplied pumps to the asphalt industry, and being a pump manufacturer we are too experienced to claim that it is easy to pump asphalt. We do however claim to have the best solution for most applications within this industry, as our experience as well as feedback from customers have been used for improvement and development.

Electrical heating as an alternative to heating by liquid/steam, is the most recent result of this. The heating source is a temperature probe, mounted in the idler pin of the pump.

As the idler pin is placed in the middle of the pump/liquid, the heating is concentrated where it is best used. For this reason it is often sufficient with heating at the front end, but heating of the rear end is of course also a possibility.



# Additional Feature for All DESMI ROTAN® Pump Types

Service on pumps without breaking any pipe connections  
- saving both time and money...

True back-pull-out feature allows inspection/repair of the rotating cartridge without disturbing the piping or coupling alignment

- Reduced downtime costs
- Reduced labour costs
- Spares optimization

ROTAN® pumps are made with a "back-pull-out" system.

This means that a pump, delivered on a base plate with a spacer coupling connecting gear or motor to the pump, can be serviced without breaking any pipe connections or moving the motor/gearbox. Just by taking out the spacer in the coupling you have access to dismantle the total rear end of the pump.

Now the ROTAN® Uptime Cartridge can be mounted in a matter of minutes thus minimizing the downtime and the cost of lost production. Furthermore you have the advantage that the cartridge, which has to be serviced, can have new/serviced components mounted/repaired without having to pay extra for fast delivery.

As an example you could have a pump with tungsten bearings and a shaft seal with SIC/SIC faces. The front cover can always be serviced without

disturbing pipes or motor/gearbox. Normally the tungsten bearings last for two or three sets of "wear parts", meaning that the bearings can be remounted in the serviced cartridge and seals can be cleaned, re-lapped and get new O-rings (with full factory warranty). In this way you save money for expensive parts, get less downtime and reduce the loss of production.

The ROTAN® mag-drive pumps can also be delivered with a free shaft end and a spacer coupling. Having this construction, you are also able to enjoy all the advantages of an Uptime Cartridge with the mag-drive pumps.

With the ROTAN® Uptime Cartridges you have lots of time to service the cartridges and thus the repair staff can service the cartridges when the work is not so hectic or the work can be carried out by one of ROTAN®'s workshops.

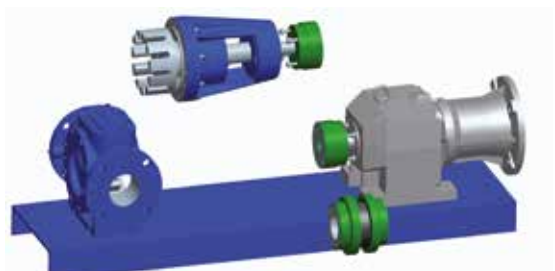
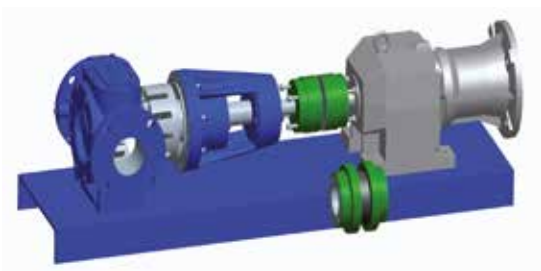
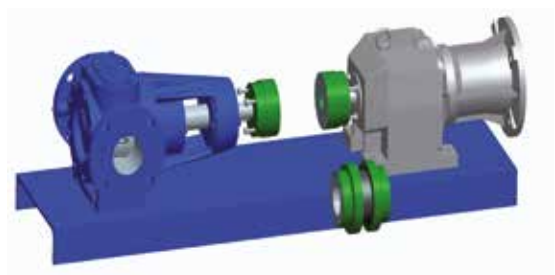
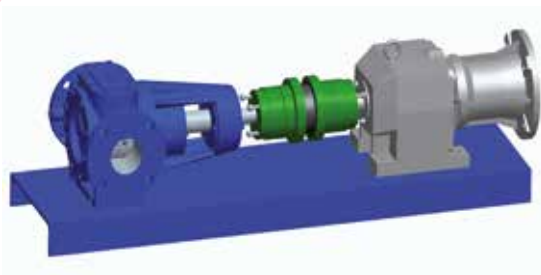
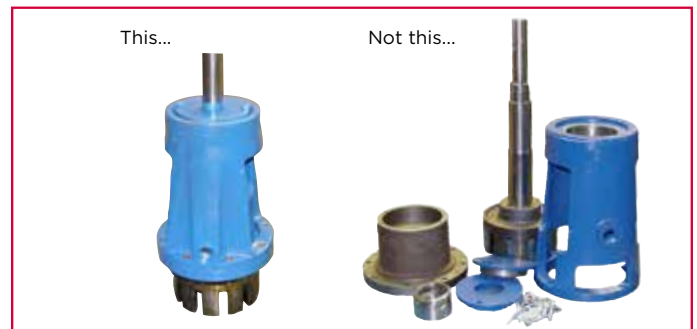

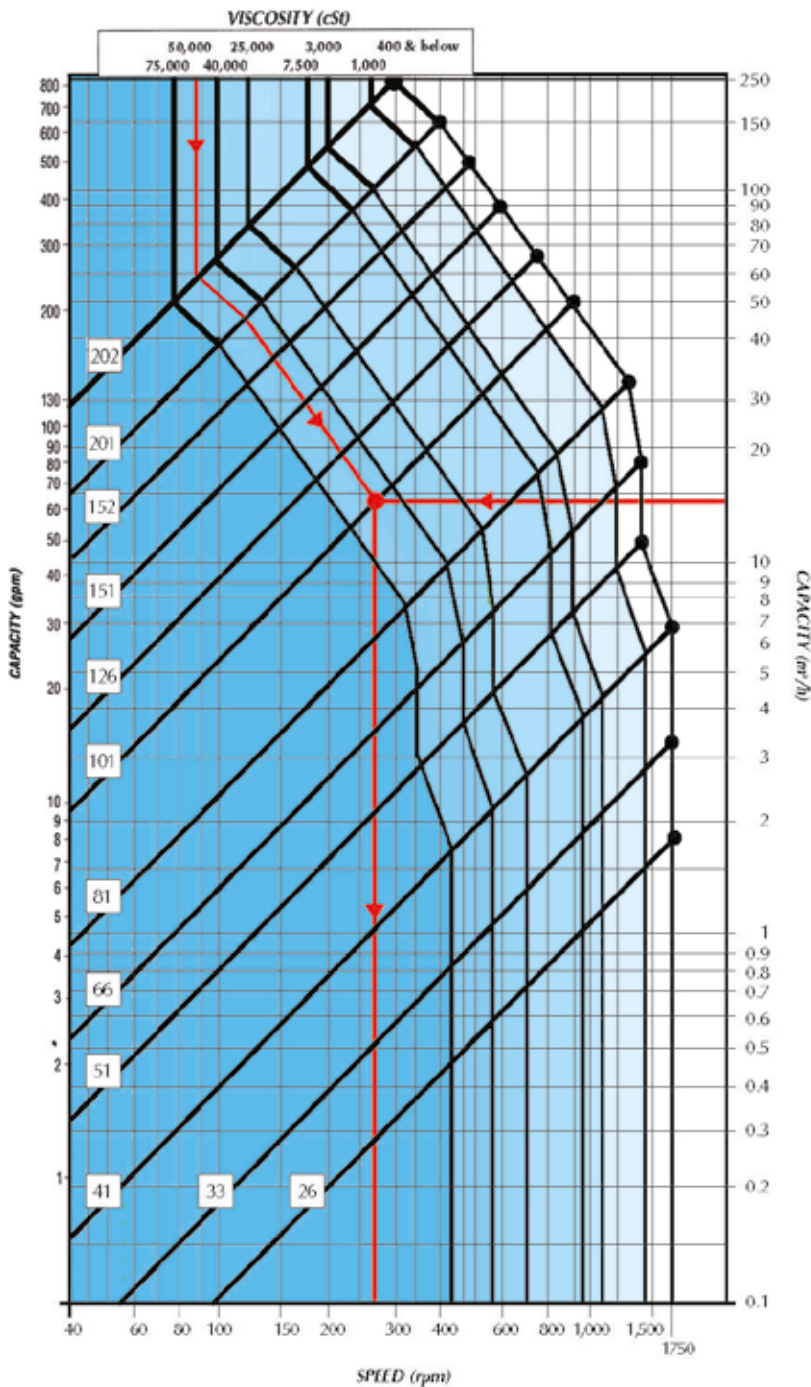

To select the pump size with this table, you should only know:

- The capacity
- The viscosity

We start at the top of the table with the viscosity, and draw a line down, staying within the colour of the selected viscosity range (see example).

Then we start at the right of the table, drawing a horizontal line starting with the required capacity (see example).

The point where these two lines meet determines the pump size, defined by the diagonal lines in the table. If you do not hit one of these pump lines exactly, increase the capacity a bit. The speed is found vertically below the point of intersection (see example).

The maximum speed of each pump is found vertically below the end of each pump line (indicated with the small black dot). This maximum speed must be reduced to max. 50% when pumping strongly abrasive liquids or emulsions.

When the differential pressure is known, the shaft power is calculated by:

$$E(KW) = 0,07 \times \text{flow (m}^3/\text{h)} \times \text{differential pressure (bar)}$$

The requested shaft power has to be increased by up to 35% when using a small ROTAN® pump in combination with high viscosity (Over 10,000 cSt).

The requested shaft power has to be decreased by up to 35% when using a big ROTAN® pump in combination with low viscosity (Under 500 cSt).

# Item References and Descriptions

---

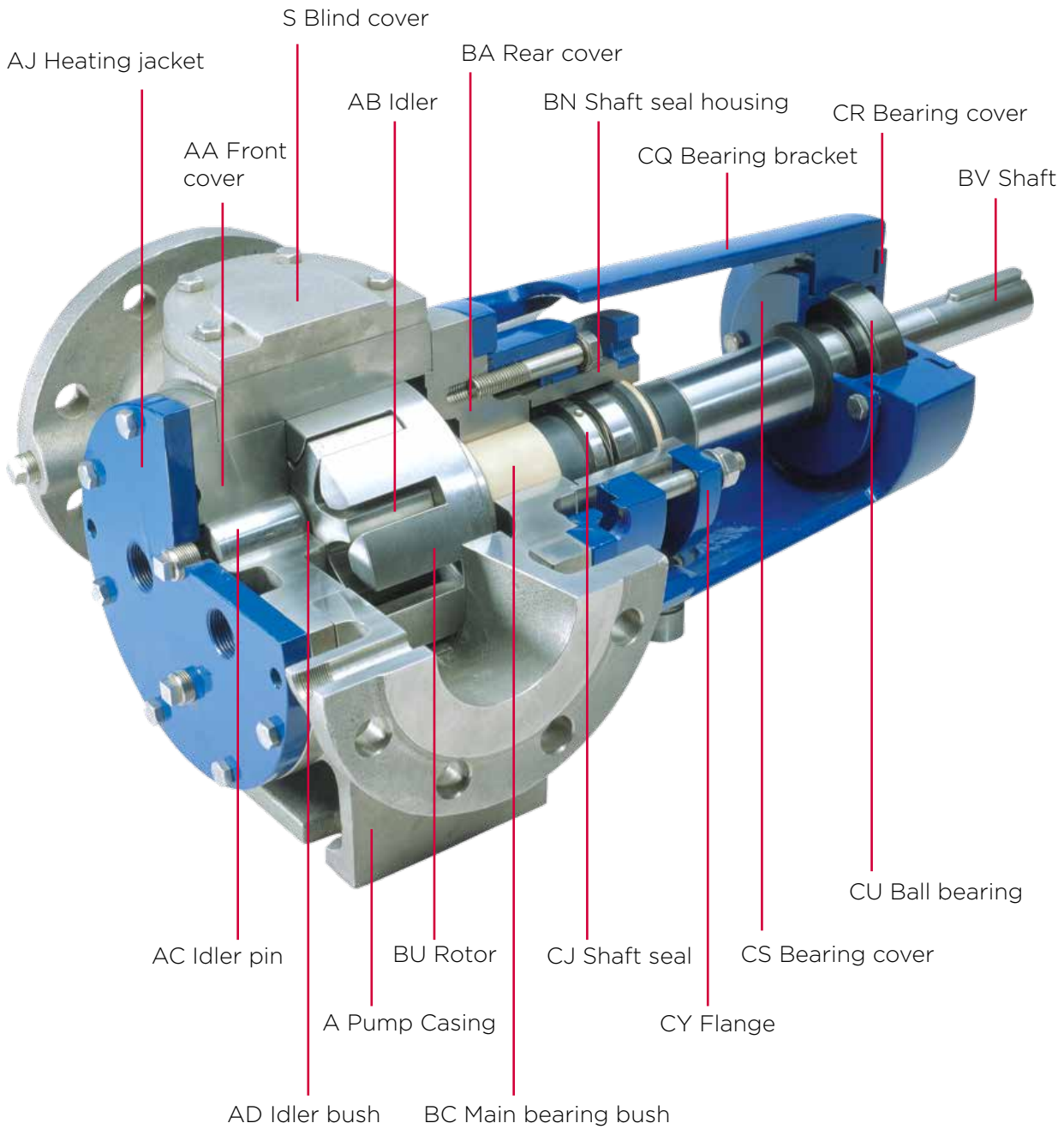



# Item References and Descriptions

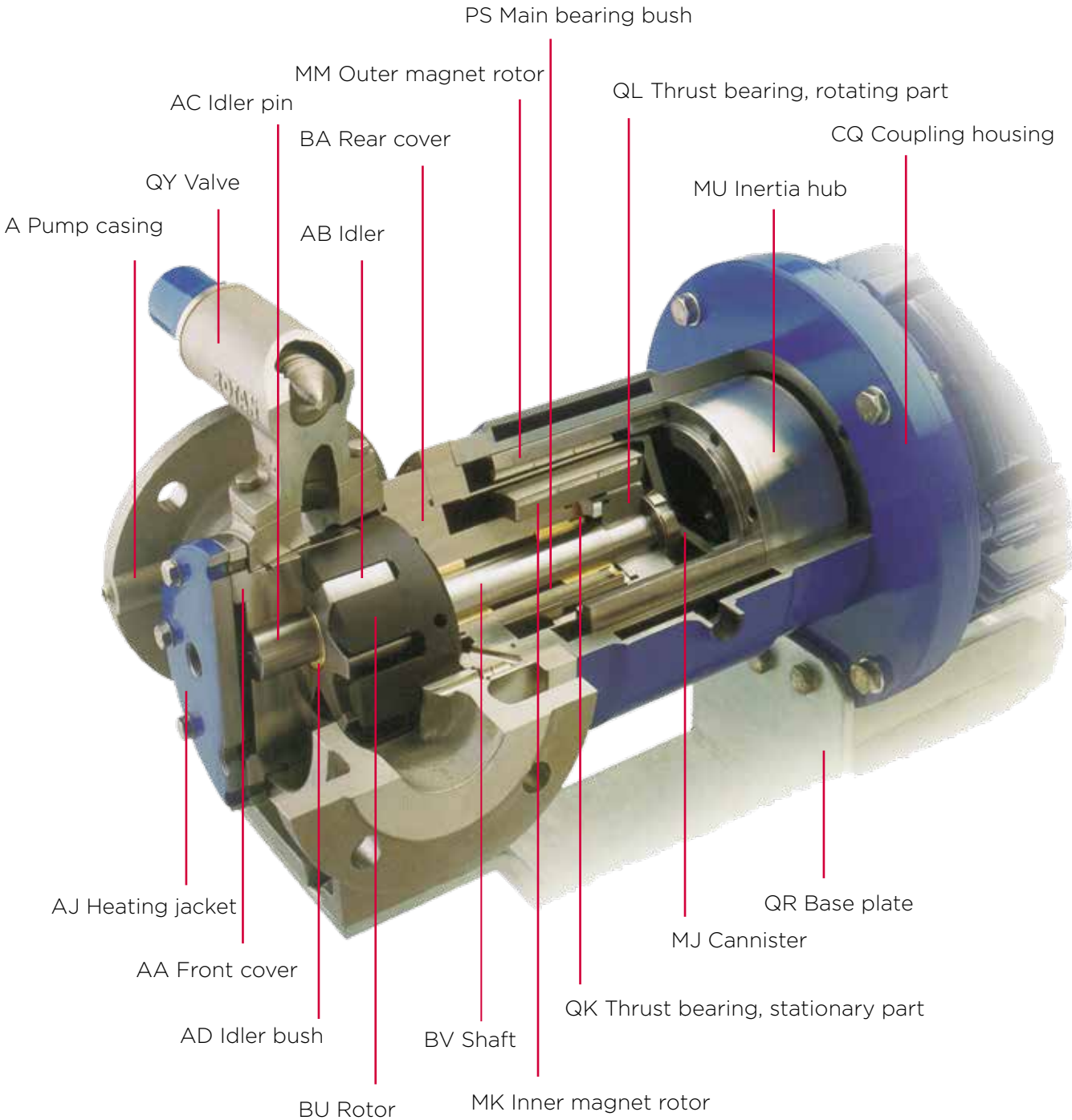

# By Indicating the Options in the Order Below, the Complete Pump Can be Identified

1) Pump series	
GP	General Purpose, monobloc in cast iron
HD	Heavy Duty pump in cast iron
PD	Petrochemical Duty pump in carbon steel
CD	Chemical Duty pump in stainless steel
ED	Environmental Duty pump, magnetically coupled, cast iron, carbon steel or stainless steel

2) Pump sizes *	
26	DN 25 - 1"
33	DN 32 - 1¼"
41	DN 40 - 1½"
51	DN 50 - 2"
66	DN 65 - 2½"
81	DN 80 - 3"
101	DN100 - 4"
124	DN100 - 4"
126	DN125 - 5"
151	DN150 - 6"
152	DN150 - 6"
201	DN200 - 8"

Available with flanges\* or female connections, depending on size and material. GP pumps are available up to and including size 101.

ED pumps are available up to size 151.

\* Flange connections according to:

ISO 2084 DIN 2501 BS 4504 1969 ANSI B 16.1/B 16.5

3) Configurations	
E	Suction/discharge connections in-line
B	Suction/discharge connections at 90° angle (not standard)
F	Flanges

Additional options, see page 19.

4)	
-	Hyphen

5) Material codes for main parts				
Code	Type	Casing/Covers	Rotor/Idler	Shaft
1	GP/HD/ED	Cast Iron (GG 25)	Cast Iron (GG 25)	Carbon Steel (St. 60.2)
3	CD/ED	316SS (G-X 6 CrNiMo 18 10)	329SS (X 8 CrNiMo 27 5)	329SS (X 8 CrNiMo 27 5)
4	PD/ED	Cast Steel (GS-52 3)	Cast Iron (GG 25)	Carbon Steel (St. 60.2)
5	HD	Cast Iron GGG40	Cast Iron GGG40	Carbon Steel

For ED pumps, all material codes may be used.

Material code 5 only for HD202.

6) Lubrication	
U	Idler bearing and main bearing lubricated by pump medium
M	Externally lubricated idler bearing and main bearing

M - Only for idler bearings on ED pumps

7) Material codes for idler bearing			
Code	Idler Bush	Idler Pin: GP-HD-PD-ED	Idler Pin: CD-ED
1	Cast iron*	Hardened Steel	329SS
2	Bronze*	Hardened Steel	329SS
3	Carbon	Hardened Steel	329SS
4	Al. oxide	Coated Steel	Coated 329SS
5	Carbon	Al.oxide, polished	Al.oxide, polished
8	Tungsten carbide	Tungsten carbide	Tungsten carbide

\*For sizes 26/33 the complete idler is made of cast iron or bronze

8) Material codes for main bearing			
Code	Bearing Bush	Shaft: GP-HD-PD	Shaft: CD
1	Cast iron	Carbon Steel	329SS
2	Bronze	Carbon Steel	329SS
3	Carbon	Carbon Steel	329SS
4*	Al. oxide	Coated Steel	Coated 329SS
8	Tungsten carbide	Coated Steel	Coated 329SS
B	Ball bearing	Carbon Steel	Not applicable

\* Not relevant for ED

9) Shaft seals	
B	Teflon-impregnated, non-asbestos packing
2	Single mechanical shaft seal, DIN 24960/EN12756 - KU, bellows type or O-ring type
22	Double mechanical shaft seal, DIN 24960/EN12756 - KU, O-ring type

\* Not relevant for ED

/XX	Magnet length: xx cm
N	Magnet material: Neodymium-iron-boron
C	Magnet material: Samarium cobalt

For ED pumps only

Example of pump identification:

**CD 41 E F MMP W D K T-3 U 3 3 22**

CD	= Chemical Duty
41	= Size (DN40/1½")
E	= In-line
F	= Flange
MMP	= Double mechanical seal (back-to-back)
W	= High pressure (16 bar)
D	= Heating jacket front
K	= Heating jacket rear
T	= Special clearance (tolerance)
3	= CD (stainless steel)
U	= Lubricated by pumped media (no external lubrication)
3	= Material code for idler bearing (Carbon)
3	= Material code for main bearing (Carbon)
22	= Double mechanical seal

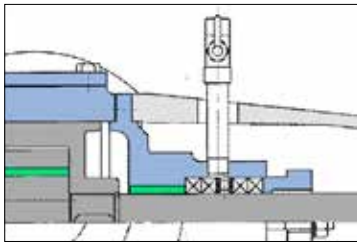

Sealing with stuffing box, with or without lantern ring, for use of external lubrication. Used for high viscosities and where some leakage is allowed.

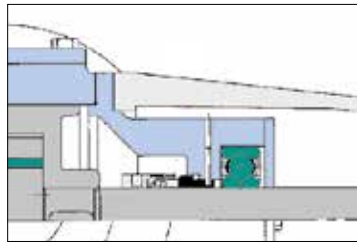

M GP/HD  
Sealing with single mechanical shaft seal, DIN 24960/EN 12756 - KU, combined with a ball bearing as main bearing. Used where only minor leakage is allowed.

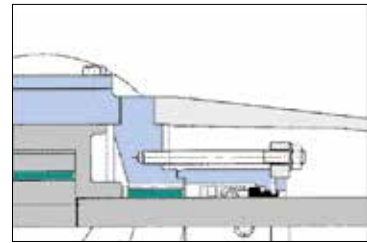

M PD/CD  
Sealing with single mechanical shaft seal, DIN 24960/EN 12756 - KU, combined with a product lubricated sleeve bearing as bearing. Used where only minor leakage is allowed.

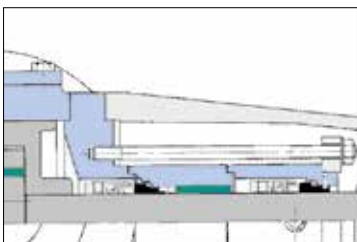

MM (Tandem) MMP (back-to-back)  
Double mechanical shaft seals, DIN 24960/EN 12756 - KU, in tandem or back-to-back, with main bearing in the barrier fluid. Used where no leakage is allowed. Up to 6 bar differential pressure.

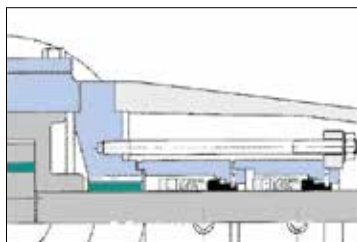

MMW (Tandem) MMPW (back-to-back)  
Double mechanical shaft seals, DIN 24960/EN 12756 - KU, in tandem or back-to-back, with product-lubricated main bearing. Used where no leakage is allowed. Up to 16 bar differential pressure.

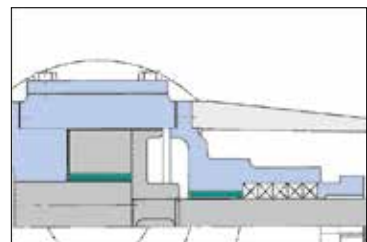

T  
Special clearances. Increase of tolerances used for liquids with viscosities above 7,500 cSt. or temperatures above 150°C.

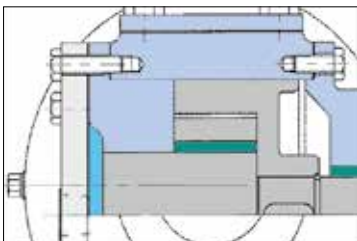

D  
Heating jackets on the front cover, often required prior to start-up when pumping high-viscosity liquids and liquids which tend to solidify.

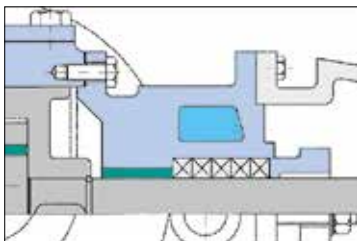

K  
Heating jackets on the rear cover, often required prior to start-up when pumping high-viscosity liquids and liquids which tend to solidify. This jacket is also used as a seal cooling jacket.

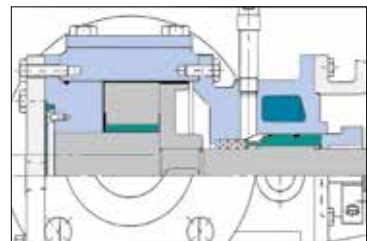

CHD  
Combination of special clearances and heating jackets together with external lubrication of the main bearing, used in the chocolate industry.

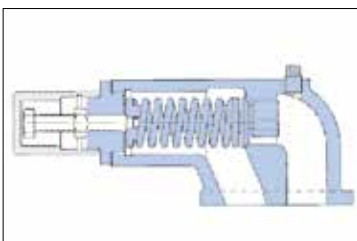

R  
Relief valve, single acting (one direction), used to protect the pump against excess pressures.

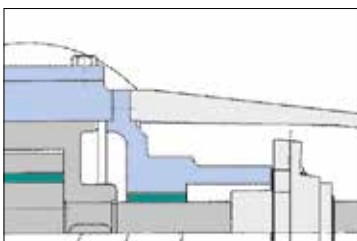

Special configurations  
Example: Customer-specified or provided cartridge seal or component.

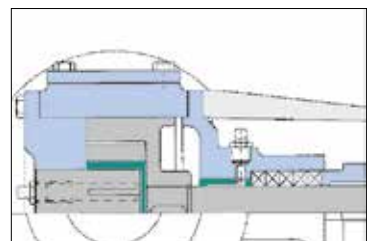

Lubrication  
Idler and main bearing externally lubricated. Used when pumping non-lubricating or very viscous fluids.



Please contact us at +45 96 32 81 11 if you have any questions,  
or read more about industry solutions at [www.desmi.com](http://www.desmi.com)

MARINE & OFFSHORE

INDUSTRY

OIL SPILL RESPONSE

DEFENCE & FUEL

UTILITY

[www.desmi.com](http://www.desmi.com)

**DESMI**