



Manual or Automatic - it's your Choice

LKB Automatic or Manual Butterfly Valve

Concept

LKB is a sanitary automatically or manually operated butterfly valve for use in stainless steel pipe systems.

Working principle

LKB is either remote-controlled by means of an actuator or manually operated by means of a handle.

The actuator is made in three standard versions, normally closed (NC), normally open (NO) and air/air activated (A/A).

The actuator is designed so that an axial movement of a piston is transformed into a 90° rotation of a shaft. The torque of the actuator is increased when the valve disc contacts the seal ring of the butterfly valve.

The handle for manual operation mechanically locks the valve in its open or closed position. The handles for the valve sizes DN125 and DN150, which are designed for locking in two intermediate positions, enable adjusting of the valve, so that the flow rate can be regulated.



TECHNICAL DATA

Valve

Max. product pressure: 1000 kPa (10 bar).
Min. product pressure: Full vacuum.
Temperature range: -10°C to +95°C.
max. temperature if valve operates

Actuator

Max. air pressure: 700 kPa (7 bar).
Min. air pressure, NC and NO: 400 kPa (4 bar).
Temperature range: -25°C to +90°C.
Air consumption (litres free air) - $\varnothing 85$
mm: 0.24 x p (bar).
Air consumption (litres free air) - $\varnothing 133$
mm: 0.95 x p (bar).
Weight: - $\varnothing 85$ mm: 3 kg.
- $\varnothing 133$ mm: 12 kg.

PHYSICAL DATA

Valve

Product wetted steel parts: 1.4307 (304L) or 1.4404 (316L).
Other steel parts: 1.4307 (304L).
Rubber grades: Q, EPDM, FPM, HNBR or PFA.
Bushes for valve disc: PVDF.
Finish: Semi-bright.

Actuator

Actuator body: 1.4307 (304L).
Piston: Light alloy (for $\varnothing 85$ mm: Bronze).
Air/air version.
Seals: Nitrile (NBR).

Standard design

LKB is available in three versions, LKB for ISO tubes, LKB-2 for DIN tubes and LKB-F for flange connection.

The valve consists of two valve body halves, valve disc, bushes for the disc stem and seal ring. LKB-F also consists of two flanges and two flange seal rings. The valve is assembled by means of screws and nuts.

Two actuator sizes, $\varnothing 85$ mm and $\varnothing 133$ mm, cover all valve sizes. The actuator is available in two versions, LKLA and LKLA-T.

The actuator is fitted onto the valve by means of a bracket and screws. (The actuator can also be fitted onto ball valves by means of special brackets).

The handle for manual operation is fitted onto the valve by means of a cap/block system and a screw.

The valve has welding ends as standard, but LKB and LKB-2 can also be supplied with fittings.

Options

- A. Male parts or clamp liners in accordance with required standard.
 - B. ThinkTop® for control and indication.*
 - C. Indication unit with micro switches.*
 - D. Indication unit with inductive proximity switches.*
 - E. Indication unit with Hall proximity switches.*
 - F. Explosion proof indication unit with inductive proximity switches.*
 - G. Bracket for actuator. (Also for ball valves).
 - H. Handle with two or four positions (standard on DN125 and DN150).
 - I. Handle for electrical position indication.
 - J. Handle with infinite intermediate positions (not for DN125 and DN150).
 - K. Multipositioning handle**.
 - L. Lockable Multiposition Handle. Padlock can be mounted as shown in fig. 3.
Note! Padlock is not delivered.
 - M. Special cap for 90° turned handle position.
 - N. Service tool for actuator.
 - O. Service tool for fitting 25-38 mm (DN25 - DN40) valve discs.
- * For further information see Product Catalogue chapter "Control & Indication".
- ** A padlock can be mounted on the Lockable Multiposition Handle as shown in the opposite figure.
- Note!** Padlock is not delivered.

Note!

For further details, see also IM 70730.

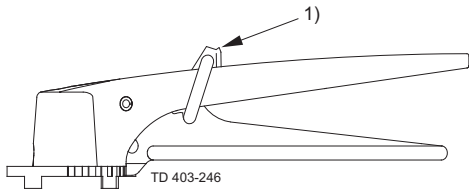

Fig. 1. Lockable Multiposition Handle with padlock.

1. Padlock

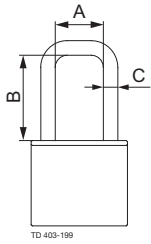

Fig. 2. Dimensions - padlock.

A. Min. 20 mm

B. Min. 35 mm

C. $\varnothing 6$ mm

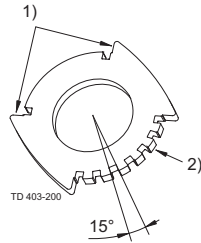
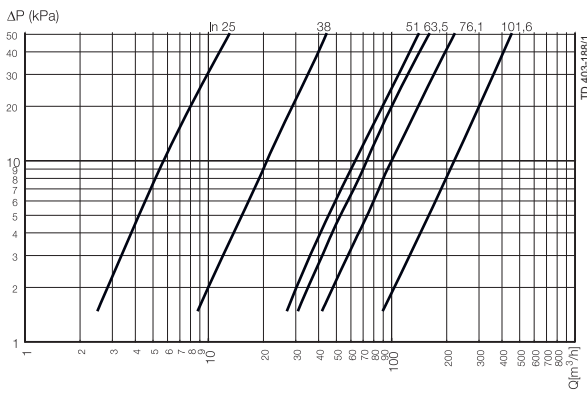

Fig. 3. Positioning cap.

1. On/Off

2. Multi positioning

Capacity/Pressure drop diagrams



LKB and LKB-F fully open

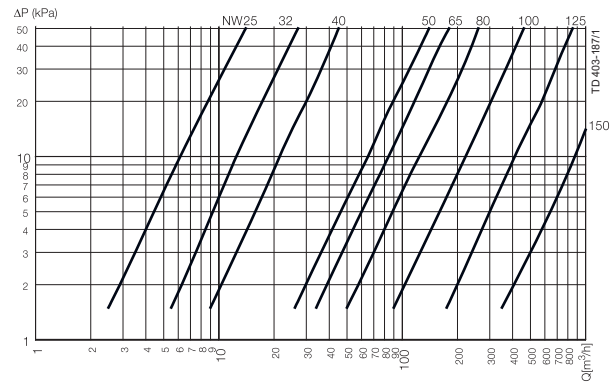

LKB-2 and LKB-F fully open

NOTE!

For the diagrams the following applies:

Medium: Water (20°C).

Measurement: In accordance with VDI 2173.

Torque diagrams - Actuator

LKLA ø85 mm:

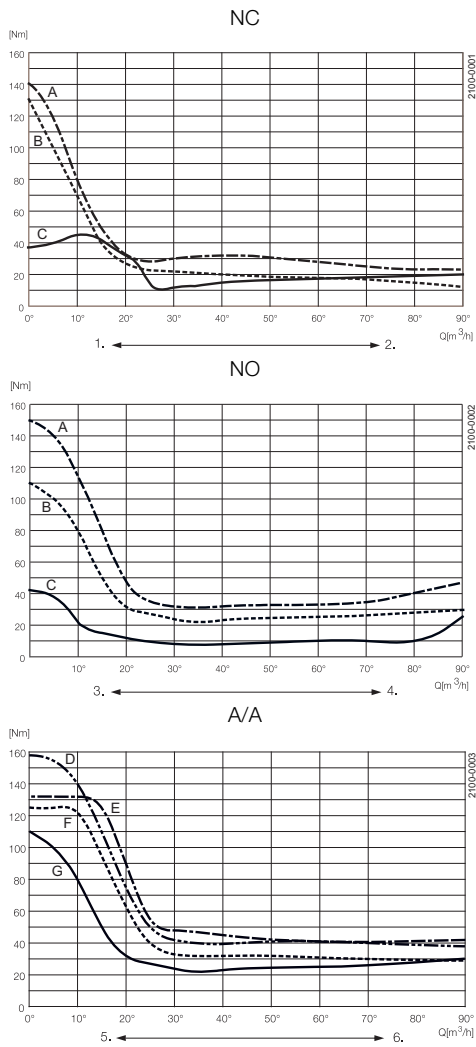

LKLA ø133 mm:

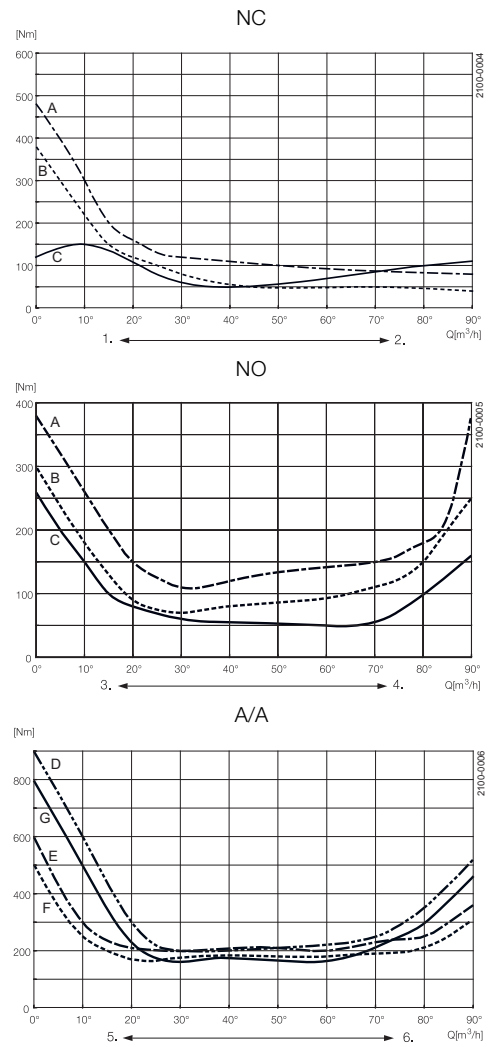

A = 6 bar air pressure
 B = 5 bar air pressure
 C = Closing/opening with spring

D = 6 bar air pressure connection on top
 E = 6 bar air pressure connection on bottom
 F = 5 bar air pressure connection on top
 G = 5 bar air pressure connection on bottom

Angular motion of actuator:
 1. Closing - Spring activated
 2. Opening - Air activated
 3. Closing - Air activated
 4. Opening - Spring activated
 5. Closing
 6. Opening

Torque values (for rotating the valve disc in a dry seal ring)

Size	Max. Nm
25mm/DN25	15
DN32	15
38mm/DN40	15
51mm/DN50	20
63.5mm/DN65	25
76mm/DN80	30
101.6mm/DN100	35
DN125	50
DN150	120

Valve Dimensions (mm)

Fig. 1. Dimensions - valve.

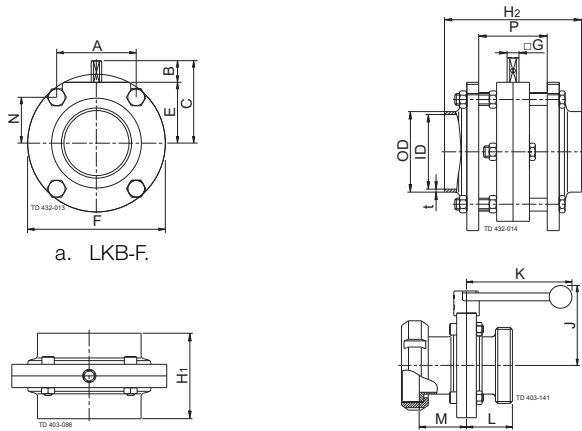

a. LKB-F.

b. LKB with welding ends.

Note! LKB sizes DN 125 and

150 are with six screws.

c. LKB with male part/nut and liner.

Fig. 2. Dimensions - actuator

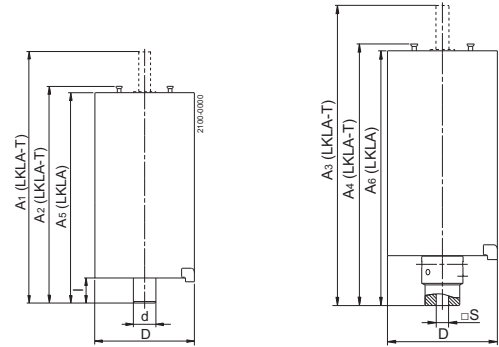

a. Without coupling.

a1 = d

b. With coupling.

b1 = □S

Dimensions (mm) - Valve

LKB, LKB-2, LKB-F:

Size	25	38	51	63.5	76.1	101.6	DN	DN	DN	DN	DN	DN	DN	DN	DN
	mm	mm	mm	mm	mm	mm	25	32	40	50	65	80	100	125	150
A	42.0	42.0	61.0	61.0	79.5	106.0	42.0	42.0	42.0	61.0	61.0	79.0	106.0	106.0	98.0
B	15.5	16.7	16.6	17.5	16.6	16.0	14.7	15.9	16.7	16.6	17.5	16.0	16.0	18.0	18.0
C	49.0	49.0	58.5	69.5	73.5	93.0	48.0	49.0	54.0	63.0	75.0	79.0	93.0	115.0	122.0
OD	25.6	38.6	51.6	64.1	76.6	102.2	30.0	36.0	42.0	54.0	70.0	85.0	104.0	129.0	154.0
ID	22.5	35.5	48.5	60.5	72.0	97.6	26.0	32.0	38.0	50.0	66.0	81.0	100.0	125.0	150.0
t	1.55	1.55	1.55	1.8	2.3	2.3	2.0	2.0	2.0	2.0	2.0	2.0	2.0	2.0	2.0
E	32.5	32.5	42.0	52.0	57.0	77.0	33.3	33.3	37.7	46.6	57.3	63.0	77.0	96.7	104.0
F	78.0	78.0	99.0	117.0	132.0	169.0	79.0	79.0	86.5	105.7	125.0	143.0	169.0	199.0	215.0
G	8.0	8.0	8.0	8.0	10.0	12.0	8.0	8.0	8.0	8.0	10.0	10.0	12.0	14.0	15.0
H ₁	47.0	47.0	52.0	54.0	62.0	80.0	47.0	47.0	47.0	52.0	62.0	64.0	80.0	110.0	80.0
H ₂	83.0	83.0	92.0	92.0	114.0	132.0	83.0	83.0	83.0	92.0	114.0	116.0	132.0	136.0	152.0
J	82.0	82.0	92.0	102.0	107.0	127.0	74.0	74.0	78.0	88.0	98.0	104.0	118.0	150.0	161.0
K	120.0	120.0	120.0	120.0	162.0	162.0	120.0	120.0	120.0	120.0	162.0	162.0	162.0	223.0	338.0
L IDF/ISO	45.0	45.0	47.5	48.5	52.5	61.5	-	-	-	-	-	-	-	-	-
M IDF/ISO	55.5	55.5	58.0	59.0	63.0	81.5	-	-	-	-	-	-	-	-	-
L DS	42.0	43.5	46.0	51.0	55.0	64.0	-	-	-	-	-	-	-	-	-
M DS	54.5	54.5	57.0	59.0	63.0	72.0	-	-	-	-	-	-	-	-	-
L SMS	38.5	43.5	46.0	51.0	55.0	75.0	-	-	-	-	-	-	-	-	-
M SMS	51.0	52.5	55.0	56.0	61.0	72.0	-	-	-	-	-	-	-	-	-
L BS	45.7	45.7	48.2	49.2	53.2	67.0	-	-	-	-	-	-	-	-	-
M BS	50.5	50.5	53.0	54.0	58.0	71.8	-	-	-	-	-	-	-	-	-
L DIN	45.5	45.5	48.0	52.0	61.0	70.0	40.0	40.0	37.0	37.0	43.0	48.0	51.0	55.0	115.0
M DIN	61.5	61.5	66.0	67.0	71.0	83.0	45.5	48.5	49.5	54.0	63.0	69.0	84.0	89.0	77.0
L Clamp	45.0	45.0	47.5	48.5	52.5	61.5	-	-	-	-	-	-	-	-	-
N	26.5	26.5	30.5	40.5	43.5	53.0	27.3	27.3	31.7	35.1	45.8	49.5	53.0	72.7	85.0
P	42.0	42.0	46.0	46.0	58.0	58.0	42.0	42.0	42.0	46.0	58.0	58.0	58.0	62.0	78.0
Weight LKB-F (kg)	1.6	1.3	2.1	2.9	5.0	7.9	1.6	1.6	1.7	2.6	4.7	5.8	7.9	11.7	12.3
Weight LKB/ LKB-2 (kg)	1.2	1.0	1.5	2.1	3.0	4.7	1.2	1.1	1.3	1.8	3.0	3.5	5.1	7.5	9.0

NOTE! Weights are for valves with welding ends and handles.

Dimensions (mm) - Actuator

LKLA and LKLA-T:

Valve size	25-63.5	76.1	101.6	101.6	DN125	DN125	DN150	DN150
	DN25-50	DN65-80	DN100	DN100				
A ₁	244	242	242	363	246	363	246	363
A ₂	193	191	191	316	195	316	195	316
A ₃	244	244	244	337	244	337	244	337
A ₄	173	173	173	290	173	290	173	290
D	85	85	85	133	85	133	85	133
d	17	17	17	30	20	30	20	30
I	16.5	16.5	16.5	34	16.5	34	16.5	34
S	8	10	12	12	14	14	15	15
Function	NC,NO,A/A	NC,NO,A/A	NC,NO,A/A	NC,NO,A/A	A/A	NC,NO,A/A	A/A	NC,NO,A/A

Connections

Compressed air

R1/8" (BSP), internal thread.

Alfa Laval reserves the right to change specifications without prior notification. ALFA LAVAL is a trademark registered and owned by Alfa Laval Corporate AB.

ESE00285EN 1201

© Alfa Laval

How to contact Alfa Laval

Contact details for all countries are continually updated on our website. Please visit www.alfalaval.com to access the information direct.