

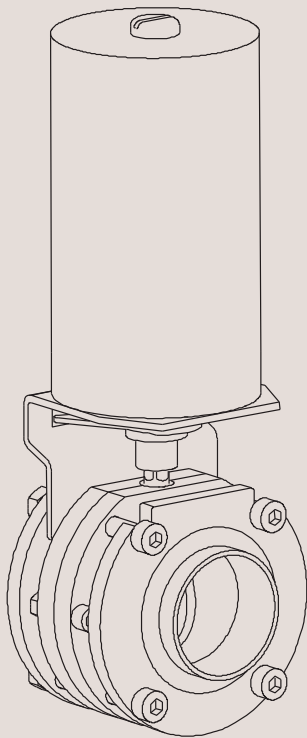

Instruction Manual

LKB Automatic or Manual Butterfly Valve and LKB-LP Low Pressure Butterfly Valve



TD 403-262

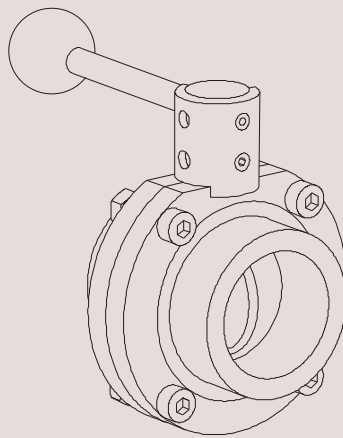

TD 403-263

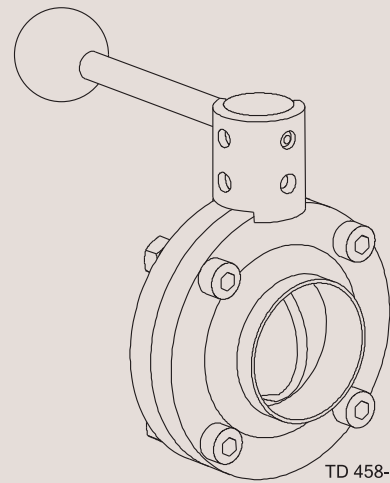

TD 458-002

IM70730-EN7 2012-09

Original Instructions

Declaration of Conformity

The designating company

Alfa Laval

Company Name

Albuen 31, DK-6000 Kolding, Denmark

Address

+45 79 32 22 00

Phone No.

hereby declare that

Automatic or Manual Butterfly Valve

Denomination

LKB

Type

Year

is in conformity with the following directives:

- Machinery Directive 2006/42/EC

DN125-DN150: The valves are in compliance with the Pressure Equipment Directive 97/23/EC and was subjected to the following assessment procedure, Module A, Category I, Fluids group 2.

**Manager, Product Centres,
Compact Heat Exchangers & Fluid Handling**

Title

Bjarne Søndergaard

Name

Alfa Laval

Company



Signature

Designation



Declaration of Conformity

The designating company

Alfa Laval

Company Name

Albuen 31, DK-6000 Kolding, Denmark

Address

+45 79 32 22 00

Phone No.

hereby declare that

Low Pressure Butterfly Valve

Denomination

LKB-LP

Type

Year

is in conformity with the following directives:

- Machinery Directive 2006/42/EC

DN125-DN150: The valves are in compliance with the Pressure Equipment Directive 97/23/EC and was subjected to the following assessment procedure, Module A, Category I, Fluids group 2.

**Manager, Product Centres,
Compact Heat Exchangers & Fluid Handling**

Title

Bjarne Søndergaard

Name

Alfa Laval

Company



Signature

Designation



The information contained herein is correct at the time of issue but may be subject to change without prior notice.

1. Safety	8
1.1 Important information	8
1.2 Warning signs	8
1.3 Safety precautions	9
2. Installation	10
2.1 Unpacking/Delivery	10
2.2 General installation	11
2.3 Welding.....	12
2.4 Fitting actuator/bracket/handle on the valve (optional extras).....	13
3. Operation	14
3.1 Operation.....	14
3.2 Fault finding	15
3.3 Recommended cleaning	16
4. Maintenance	17
4.1 General maintenance	17
4.2 Dismantling of valve - LKB/LKB-2	19
4.3 Assembly of valve - LKB/LKB-2	20
4.4 Dismantling of valve - LKB-F	21
4.5 Assembly of valve - LKB-F	22
4.6 Dismantling of actuator	23
4.7 Assembly of actuator	24
5. Technical data	25
5.1 Technical data	25
6. Parts List / Service kits	26
6.1 LKB, LKB-2, LKB-F Butterfly valves, Drawings	26
6.2 LKB-LP Butterfly Valve, Drawings.....	27
6.3 LKLA and LKLA-T Actuators Ø85 mm, Drawings	28
6.4 LKLA and LKLA-T Actuators Ø133 mm, Drawings	29
6.5 LKB Butterfly valve - Parts list	30
6.6 LKB-F Butterfly valve - Parts list	32
6.7 LKB-2 Butterfly valve - Parts list	34
6.8 LKB-LP Butterfly Valve- Parts list.....	36
6.9 LKLA Actuators ø85 mm (NO/NC) - Parts list	38
6.10 LKLA Actuators ø85 mm (A/A) - Parts list.....	40
6.11 LKLA Actuators DN 125 - 150 ø85 mm (A/A)	42
6.12 LKLA Actuators ø133 mm (NO/NC).....	44
6.13 LKLA Actuators ø133 mm (A/A)	46
6.14 LKLA-T ø85 mm (NO/NC)	48
6.15 LKLA-T ø85 mm (A/A).....	50
6.16 LKLA-T DN 125 - 150 ø85 mm (A/A).....	52
6.17 LKLA-T ø133 mm (NO/NC)	54
6.18 LKLA-T ø133 mm (A/A)	56
6.19 Handles	58

1.1 Important information

1.2 Warning signs

*Unsafe practices and other important information are emphasized in this manual.
Warnings are emphasized by means of special signs.*

Always read the manual before using the valve!

WARNING!

Indicates that special procedures **must** be followed to avoid severe personal injury.

CAUTION!

Indicates that special procedures **must** be followed to avoid damage to the valve.

NOTE!

Indicates important information to simplify or clarify practices.

General warning.



Caustic agents.



Transportation:

Always secure that compressed air is released

Always secure that all connections is disconnected before attempt to remove the valve from the installation

Always drain liquid out of valves before transportation

Always used predesigned lifting points if defined

Always secure sufficient fixing of the valve during transportation - if special designed packaging material is available it must be used

Recycling information.

• **Unpacking**

- Packing material consists of wood, plastics, cardboard boxes and in some cases metal straps.
- Wood and cardboard boxes can be reused, recycled or used for energy recovery.
- Plastics should be recycled or burnt at a licensed waste incineration plant.
- Metal straps should be sent for material recycling.

• **Maintenance**

- During maintenance oil and wear parts in the machine are replaced.
- All metal parts should be sent for material recycling.
- Worn out or defective electronic parts should be sent to a licensed handler for material recycling.
- Oil and all non metal wear parts must be taken care of in agreement with local regulations.

• **Scrapping**

- At end of use, the equipment shall be recycled according to relevant, local regulations. Beside the equipment itself, any hazardous residues from the process liquid must be considered and dealt with in a proper manner. When in doubt, or in the absence of local regulations, please contact the local Alfa Laval sales company.

All warnings in the manual are summarized on this page.

“Mushrooms” = Fastening connections on the end cap.

Pay special attention to the instructions below so that severe personal injury or damage to the valve are avoided.

Installation:

- **Always** observe the technical data (see chapter 5).
- **Always** release compressed air after use.
- **Never** touch the coupling between the valve body and the actuator if compressed air is supplied to the actuator.



Operation:

Always observe the technical data (see chapter 5).

Never touch the valve or the pipelines when processing hot liquids or when sterilizing.

Never touch the coupling between the valve body and the actuator if compressed air is supplied to the actuator.



Always handle lye and acid with great care.



Maintenance:

- **Always** observe the technical data (see chapter 5)
- **Always** release compressed air after use.
- The valve must **never** be hot when servicing it.
- The valve/actuator and the pipelines must **never** be pressurised when servicing the valve/actuator.



Never stick your fingers through the valve ports if the valve is supplied with compressed air.

Never touch the coupling between the valve body and the actuator if compressed air is supplied to the actuator.

The actuator springs are **not** caged (ø85 mm, NC/NO).



- **Never** use compressed air for removing the end cap of the actuator.
- **Always** fit the end cap with the “mushrooms” turned outwards and position it correctly before supplying compressed air to the actuator.



The instruction manual is part of the delivery. Study the instructions carefully.

The items refer to the parts list and service kits section.

The valve is supplied as separate parts as standard (for welding).

The valve is assembled before delivery, if it is supplied with fittings (LKB/LKB-2).

Step 1

NOTE!

Alfa Laval cannot be held responsible for incorrect unpacking.

Check the delivery:

1. Complete valve (see 2).
2. Complete actuator, if supplied (see 3).
3. Bracket for actuator, if supplied (see 3).
4. Complete handle, if supplied.
5. Delivery note.
6. Instruction manual.

Step 2

Standard delivery of valve parts:

1. Two valve body halves (1).
2. Valve disc (2) fitted in seal ring (5).
3. Two bushes (3, 4) fitted on the disc stem.
4. A set of screws and nuts (6).
5. Two flanges (7) and two flange seal rings(8), (LKB-F).

Separate parts for welding!

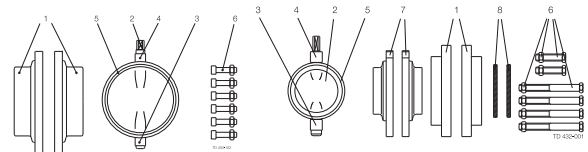

LKB/LKB-2

LKB-F (only for welding)

Step 3

Delivery of actuator and bracket:

1. Complete actuator with coupling and activating ring (ø85mm) or indication pin (ø133mm).
2. Bracket with screws for the actuator.

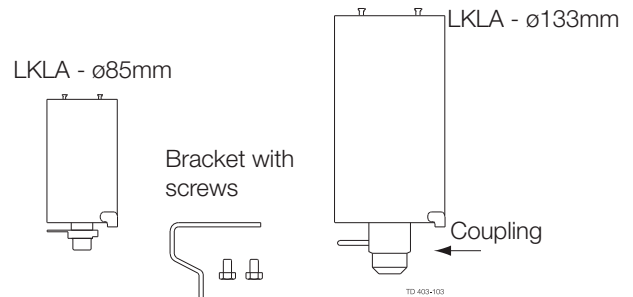

Step 4

1. Clean the valve/valve parts for possible packing materials.
2. Clean the handle or the actuator, if supplied.

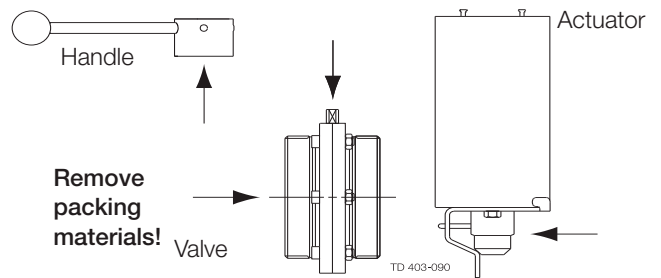

Step 5

Inspection!

1. Inspect the valve/valve parts for visible transport damage.
2. Inspect the handle or the actuator, if supplied.

Caution!

Avoid damaging the valve/valve parts.
 Avoid damaging the handle or the actuator, if supplied.

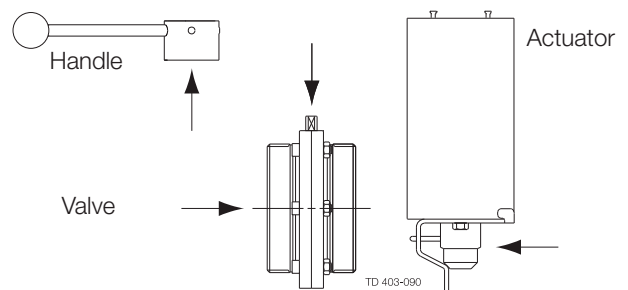

Study the instructions carefully. The valve has welding ends as standard but can also be supplied with fittings (not LKB-F).

NC = Normally closed.

NO = Normally open.

A/A = Air/air activated.

Step 1



- **Always** observe the technical data (see chapter 5).
- **Always** release compressed air after use.
- **Never** touch the coupling between the valve body and the actuator if compressed air is supplied to the actuator.

NOTE!

Alfa Laval cannot be held responsible for incorrect installation.

Step 2

Avoid stressing the valve.

Pay special attention to:

- Vibrations.
- Thermal expansion of the tubes.
- Excessive welding.
- Overloading of the pipelines.

Risk of damage!

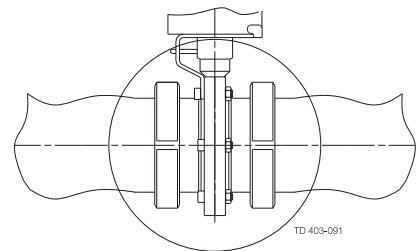

Step 3

Fittings:

Ensure that the connections are tight.

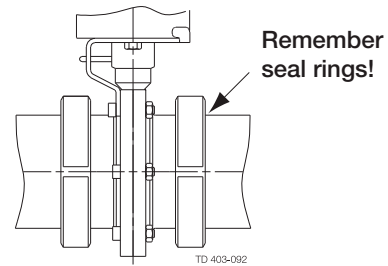

Step 4

Position of actuator:

Position the water rejector on the actuator correctly. (The actuator can be installed in any position).

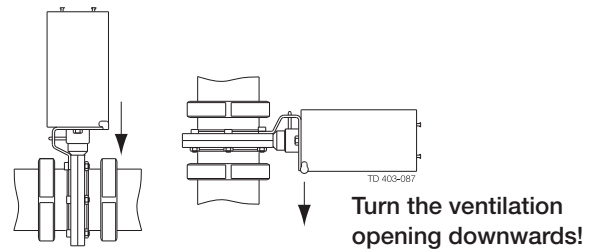

Air connection of actuator:

Connect compressed air correctly.

Pay special attention to the warnings!

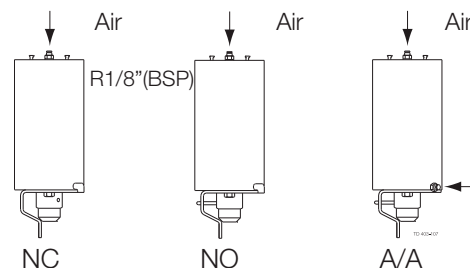

Pre-use check:

Open and close the valve several times to ensure that the valve disc moves smoothly against the sealing.

Pay special attention to the warnings!

Study the instructions carefully. The valve is supplied as separate parts to facilitate the welding.

LKB: For ISO tubes.

LKB-2: For DIN tubes.

LKB-F: With flange connection.

LKB/LKB-2

1. Weld the valve body halves into the pipelines.
2. Maintain the minimum clearance (A) so that the actuator can be removed.
3. If welding both valve body halves, ensure that they can be moved axially B_1 mm, so that the valve parts can be removed.
4. Assemble the valve in accordance with the steps 1-5 in section 4.3 after the welding.

LKB-F

1. Weld the flanges into the pipelines.
2. Maintain the minimum clearances (A and B_2) so that the actuator and the valve parts can be removed.
3. Assemble the valve in accordance with the steps 1-5 in section 4.3 after welding.

Pre-use check - LKB/LKB-2/LKB-F:

Open and close the valve several times to ensure that the valve disc moves smoothly against the seal ring.

Pay special attention to the warnings!

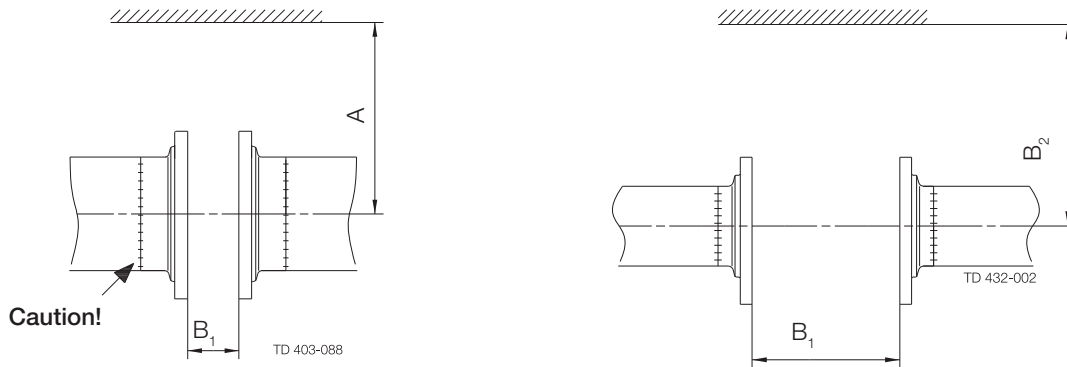

	A(mm)		Ø85 Ø133	
	LKLA	LKLA-T	LKLA	LKLA-T
1"	245			
1½"	245			
2"	255			
2½"	265			
3"	265			
4"	290	+172	420	+172
DN25	245	(incl.		(incl.
DN32	245	top		top
DN40	250	unit)		unit)
DN50	260			
DN65	270			
DN80	275			
DN100	290		420	
DN125	315		440	
DN250	325		445	

	B_1 (mm)	B_2 (mm)
1"	20	43
1½"	20	43
2"	20	47
2½"	24	46
3"	24	59
4"	37	59
DN25	20	43
DN32	20	43
DN40	20	43
DN50	20	47
DN65	24	59
DN80	23	59
DN100	37	59
DN125	40	63
DN250	41	79

Study the instructions carefully and pay special attention to the warnings!

NC = Normally closed.

NO = Normally open.

A/A = Air/air activated.

Bracket/indication:

1. Fit the bracket as shown.
2. Fit and tighten the screws.
3. Fit the activating ring/indication pin as shown.

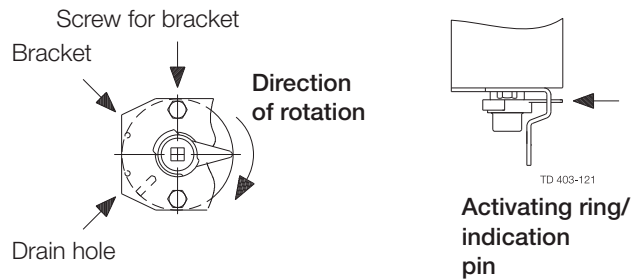

Actuator/bracket - NC:

1. Ensure that the valve is closed by checking the position of the groove of the disc stem top.
2. Fit the actuator/bracket in accordance with step 4 in section 4.3.

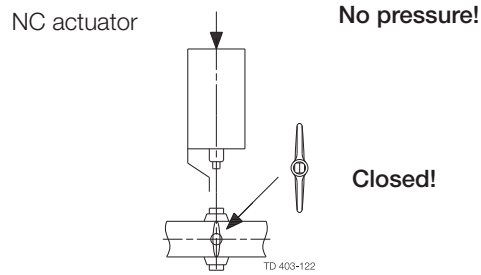

Actuator/bracket - NO:

1. Ensure that the valve is open by checking the position of the groove of the disc stem top.
2. Fit the actuator/bracket in accordance with step 4 in section 4.3.

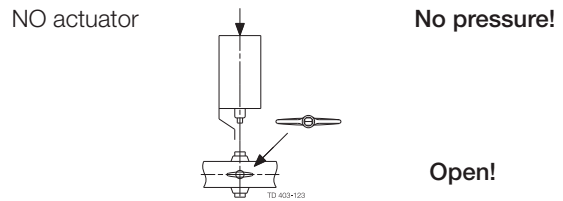

Actuator/bracket - A/A:

1. Ensure that the valve is open by checking the position of the groove of the disc stem top.
2. Supply compressed air to the actuator.
3. Fit the actuator/bracket in accordance with step 4 in section 4.3.

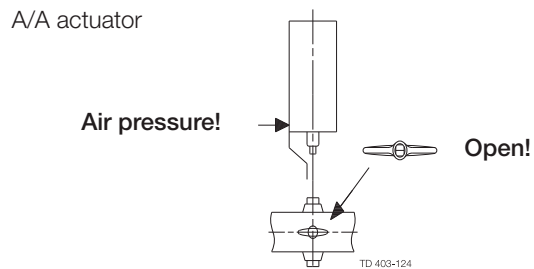

Handle/indication:

1. Fit the standard handle on the valve so that the screw can enter the hole in the disc connection.
2. Fit the handle with position indication as shown and in accordance with the steps 3-4 in section 4.3.

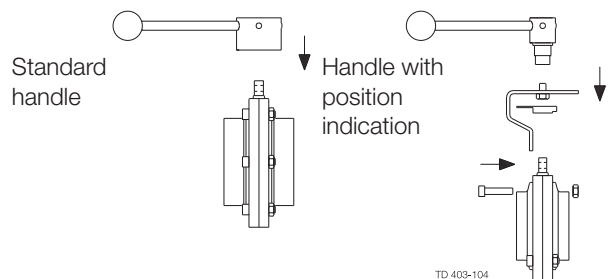

Pre-use check:

Open and close the valve several times to ensure that it operates smoothly.

Pay special attention to the warnings!

Study the instructions carefully and pay special attention to the warnings!
The valve is automatically or manually operated by means of an actuator or a handle.

Step 1



Always observe the technical data (see chapter 5).

NOTE!

Alfa Laval cannot be held responsible for incorrect operation.

Step 2



Never touch the valve or the pipelines when processing hot liquids or when sterilizing.

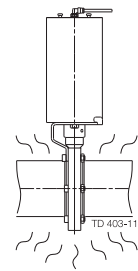

Burning danger!



Step 3



Never touch the coupling between the valve body and the actuator if compressed air is supplied to the actuator.

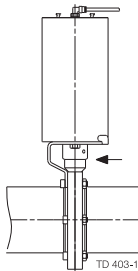

Air

Rotating parts!

Step 4

Operation by means of actuator:

Automatic on/off operation by means of compressed air.

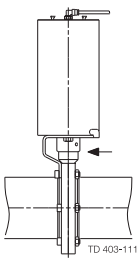

Air

Rotating parts!

Step 5

Operation by means of standard handle:

1. Manual on/off operation.
2. Pull the handle outwards while rotating it.

NOTE!

This also applies for the Lockable Multiposition Handle.

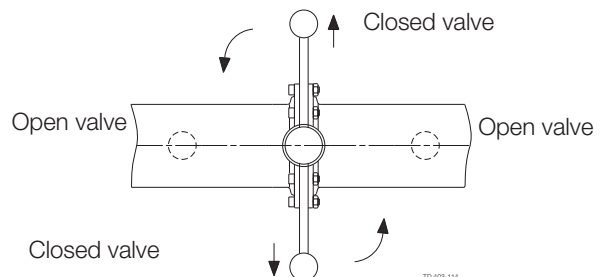

Step 6

Operation by means of regulating handle:

1. Manual flow regulation because of infinite locking positions.
2. Loosen the handle, rotate it and tighten again.

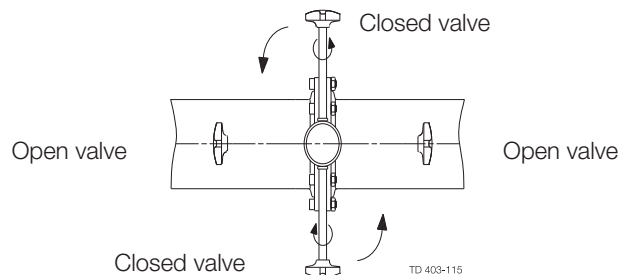

Pay attention to possible break-down. Study the instructions carefully.

LKB-F: With flange connection.

NC = Normally closed. NO = Normally open. A/A = Air/air activated.

NOTE!

Study the maintenance instructions carefully before replacing worn parts. - See section 4.1

Problem	Cause/result	Repair
<ul style="list-style-type: none"> - External leakage - Internal leakage by closed valve (normal wear) 	<ul style="list-style-type: none"> - Worn seal ring - Worn flange seal ring (LKB-F) 	Replace the seal ring and the bushes
<ul style="list-style-type: none"> - External leakage - Internal leakage by closed valve (too early) 	<ul style="list-style-type: none"> - High pressure - High temperature - Aggressive liquids - Many activations 	<ul style="list-style-type: none"> - Change rubber grade - Change the operation conditions
<ul style="list-style-type: none"> - Difficult to open/close - Damage of disc connection (high torque) 	Incorrect seal ring (swelling)	Replace by a seal ring of a different rubber grade
Difficult to open/close	<ul style="list-style-type: none"> - 90° displacement of the actuator - Incorrect actuator function (NC,NO) - Worn actuator bearings - Dirt penetration into the actuator 	<ul style="list-style-type: none"> - Fit correctly (see section 2.4) - Change from NC to NO or vice versa - Replace the bearings - Service the actuator

The valve is designed for cleaning in place (CIP). CIP = Cleaning In Place.
 Study the instructions carefully and pay special attention to the warnings!
 NaOH = Caustic Soda.
 HNO₃ = Nitric acid.

Step 1



Always handle lye and acid with great care.

Caustic danger!



Always use rubber gloves! **Always** use protective goggles!

Step 2



Never touch the valve or the pipelines when sterilizing.

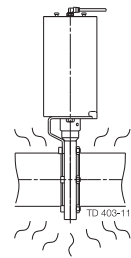

Burning danger!



Step 3

Examples of cleaning agents:
 Use clean water, free from chlorides.

1. 1% by weight NaOH at 70°C (158°F).

1 kg (2.2 lbs) NaOH	+	100 l (26.4 gal) water	= Cleaning agent.
------------------------	---	---------------------------	-------------------

2.2 l (0.6 gal) 33% NaOH	+	100 l (26.4 gal) water	= Cleaning agent.
-----------------------------	---	---------------------------	-------------------

2. 0.5% by weight HNO₃ at 70°C (158°F).

0.7 l (0.2 gal) 53% HNO ₃	+	100 l (26.4 gal) water	= Cleaning agent.
---	---	---------------------------	-------------------

Step 4

1. Avoid excessive concentration of the cleaning agent
 ⇒ **Dose gradually!**
2. Adjust the cleaning flow to the process
 ⇒ **Sterilization of milk/viscous liquids**
 ⇒ **Increase the cleaning flow!**

Always rinse well with clean water after the cleaning.

Always!

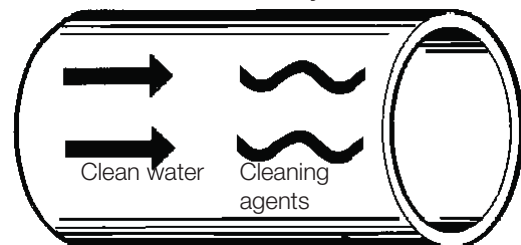

Step 6

NOTE!

The cleaning agents must be stored/discharged in accordance with current rules/directives.

Maintain the valve and the actuator carefully. Study the instructions carefully and pay special attention to the warnings!

Always keep spare seal rings, rubber seals, bushes and actuator bearings in stock.
 "Mushrooms" = Fastening connections on the end cap.

Step 1



- **Always** observe the technical data (see chapter 5).
- **Always** release compressed air after use.

NOTE!

All scrap must be stored/discharged in accordance with current rules/directives.

Step 2



- The valve must **never** be hot when servicing it.
- The valve/actuator and the pipelines must **never** be pressurised when servicing the valve/actuator.

Atmospheric pressure required!

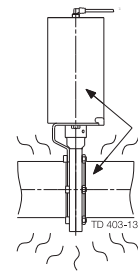

Step 3



Never stick your fingers through the valve ports if compressed air is supplied to the actuator.

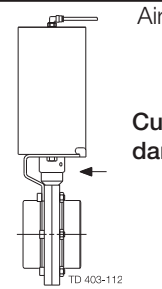

Cutting danger!



Step 4



Never touch the coupling between the valve body and the actuator if compressed air is supplied to the actuator.

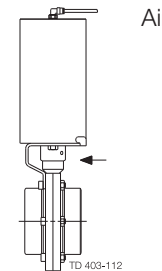

Rotating parts!

Step 5



Actuator size ø85mm (NC/NO):
 The actuator springs are **not** caged.

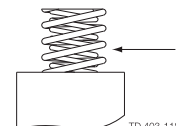

Springs - Caution!

Step 6



End cap of actuator:

- **Never** remove the end cap by using compressed air.
- **Always** fit the end cap with the "mushrooms" turned outwards and position it correctly before supplying compressed air to the actuator.

Caution!

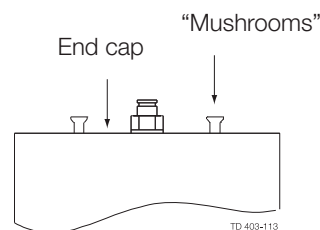

Maintain the valve and the actuator carefully.
 Study the instructions carefully.
 Always keep spare seal rings, rubber seals, bushes and actuator bearings in stock.

Recommended spare parts: Service kits (see chapter 6).
 Order service kits from the service kits list (see chapter 6)

Ordering spare parts
 Contact the Sales Department.

	Valve seal rings	Valve bushes	Actuator rubber seals	Actuator bearings
Preventive maintenance	Replace after 12 months	Replace when replacing the valve seal rings	Replace after 24 months	
Maintenance after leakage (leakage normally starts slowly)	Replace by the end of the day	Replace when replacing the valve seal rings	Replace when possible	
Planned maintenance	<ul style="list-style-type: none"> - Regular inspection for leakage and smooth operation - Keep a record of the valve - Use the statistics for planning of inspections Replace after leakage	Replace when replacing the valve seal rings	<ul style="list-style-type: none"> - Regular inspection for leakage and smooth operation - Keep a record of the actuator - Use the statistics for planning of inspections Replace after air leakage	Replace when they become worn
Lubrication	Before fitting (use USDA-H1 approved) - Unisilcon L641(*) - Paraliq (*) GTE 703 - Molycote 111 (D)	None	Before fitting - Molycote Long term 2 Plus (Δ) - Molycote 1132(Δ) (for aggressive environment)	When replacing actuator rubber seals - Molycote Long term 2 Plus (Δ) - Molycote 1132 (Δ) (for aggressive environment)

Study the instructions carefully. The items refer to the parts list and service kits section.

Handle scrap correctly.

LKB: For ISO tubes.

LKB-2: For DIN tubes.

Step 1

Valve with actuator:

1. Remove screws and nuts (6).
2. Remove the bracket with the actuator.

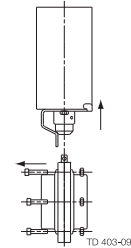

Step 2

Valve with handle:

1. Remove the complete handle.
2. Remove screws and nuts (6).

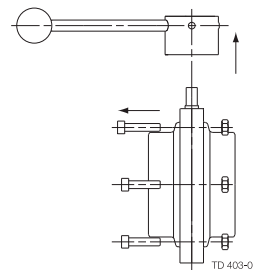

Step 3

Remove seal ring (5) together with valve disc (2).

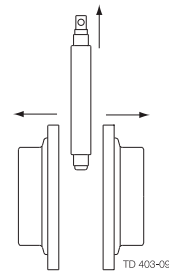

Step 4

Remove bushes (3,4) from the disc stems.

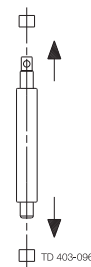

Step 5

Remove valve disc (2) from seal ring (5).

NOTE!

For the valve sizes 25-38mm and DN25-40 it is recommended to remove the valve disc by using a special service tool.

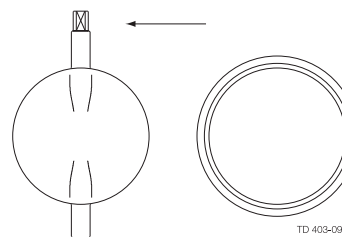

Study the instructions carefully. The items refer to the parts list and service kits section.

LKB: For ISO tubes. LKB-2: For DIN tubes.

Lubricate the seal ring before fitting it.

Lubricate the disc stem before fitting the bushes.

Step 1

1. Lubricate the pin holes in seal ring (5), (important for Silicone and Viton).
2. Fit valve disc (2) in the seal ring (5).

NOTE!

For the valve sizes 25-38mm and DN25-40 it is recommended to fit the valve disc by using a special service tool.

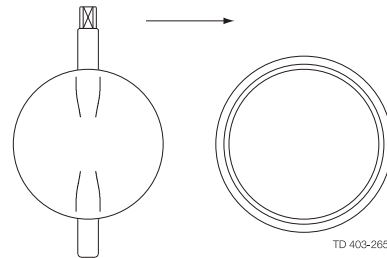

Step 2

1. Fit bushes (3,4) on the disc stem.
2. Fit seal ring (5) together with valve disc (2) between the two valve body halves (1).

CAUTION!

Rotate the valve disc so that the valve is open before tightening screws and nuts (6).

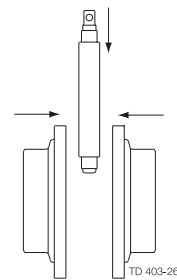

Step 3

Valve with handle:

1. Fit screws and nuts (6) and torque tighten in accordance with the requirements (see 5).
2. Fit the complete handle on the disc connection and tighten the screw on the handle.

NOTE!

This also applies for the Lockable Multiposition Handle.

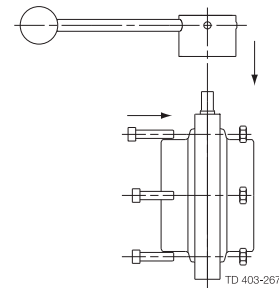

Step 4

Valve with actuator:

1. Fit the actuator with the bracket so that the disc connection enters the coupling (see section 2.4).
2. Fit screws and nuts (6) and torque tighten in accordance with the requirements so that the bracket is fixed to the valve (see 5).

**Fit correctly!
(See section 2.4)**

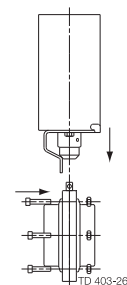

Step 5

Pre-use check:

Check that the valve disc moves smoothly against the seal ring.

Pay special attention to the warnings!

Tools/torque values for assembly of the valve body halves:

Valve size	25mm DN 25	38mm DN32	51mm DN40	63.5mm DN50	76mm DN65	101.6mm DN80	101.6mm DN100	101.6mm DN125	101.6mm DN150
Allen Key	5mm (0,2")	5mm (0,2")	5mm (0,2")	6mm (0,24")	6mm (0,24")	6mm (0,24")	8mm (0,3")	8mm (0,3")	8mm (0,3")
Recomm.Torque	18Nm (13 lbf-ft)	18Nm (13 lbf-ft)	18Nm (13 lbf-ft)	20Nm (15 lbf-ft)	20Nm (15 lbf-ft)	20Nm (15 lbf-ft)	38Nm (28 lbf-ft)	38Nm (28 lbf-ft)	38Nm (28 lbf-ft)

Study the instructions carefully.

The items refer to the parts list and service kits section.

Handle scrap correctly.

LKB-F: With flange connection.

Step 1

1. Loosen the two upper screws and nuts (6).
2. Loosen and remove the two lower screws and nuts (6).
3. Remove the valve unit from flanges (7).

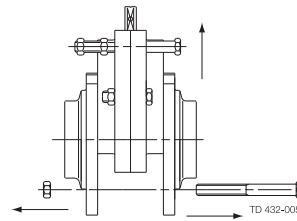

Step 2

1. Remove the two upper screws and nuts (6), (4 nuts)
2. If supplied, remove the actuator from the valve body unit.
3. If supplied loosen the screw and remove the handle from the valve body unit.

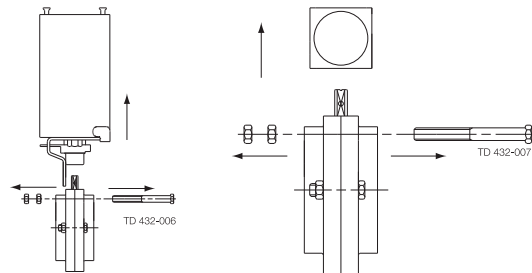

Step 3

1. Loosen and remove the two center screws and nuts (6).
2. Remove seal ring (5) together with valve disc (2).
3. Remove flange seal rings (8).

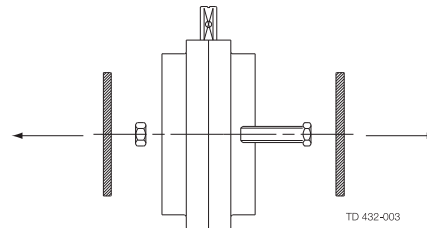

Step 4

Remove bushes (3,4) from the disc stems.

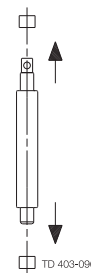

Step 5

Remove valve disc (2) from seal ring (5).

NOTE!

For the valve sizes 25-38mm and DN25-40 it is recommended to remove the valve disc by using a special service tool.

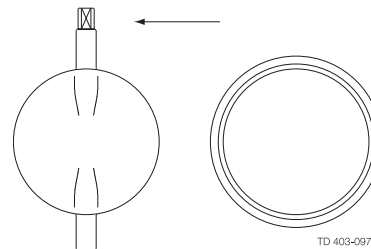

Study the instructions carefully. The items refer to the parts list and service kits section.

LKB-F: With flange connection,
Lubricate the seal rings before fitting them.

Lubricate the disc stem before fitting the bushes.

Step 1

1. Lubricate the pin holes in seal ring (5), (important for Silicone and Viton).
2. Fit valve disc (2) on seal ring (5).
3. Fit bushes (3,4) in the disc stem.

NOTE!

For the valve size 25-38mm and DN25-40 it is recommended to fit the valve disc by using a special service tool.

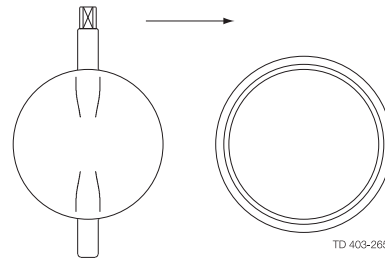

Step 2

1. Lubricate flange seal rings (8) with water and fit them.
2. Fit seal ring (5) together with valve disc (2) between the valve body halves (1).
3. Fit and tighten the two center screws and nuts (6).

CAUTION!

Rotate the valve disc so that the valve is open before tightening screws and nuts (6).

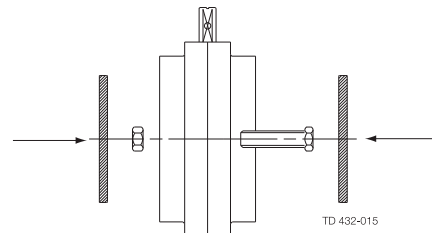

Step 3

1. If supplied, fit the handle and tighten the screw.
2. If supplied, fit the actuator.
3. Fit the two upper screws and nuts (6), (4 nuts).

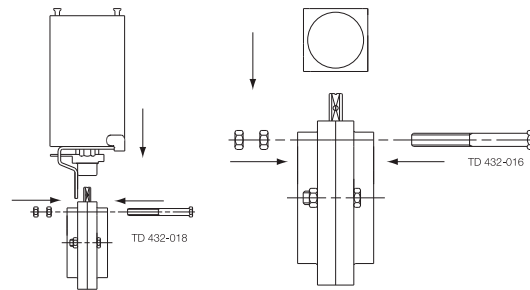

Step 4

1. Fit the valve unit between flanges (7).
2. Fit and tighten the two lower screws and nuts (6).
3. Tighten the two upper screws and nuts (6).

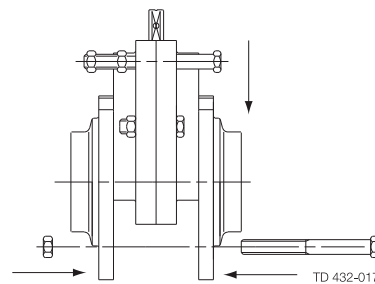

Step 5

Pre-use check:

Check that the valve disc moves smoothly against the seal ring.

Pay special attention to the warnings!

Tools/torque values for assembly of the valve body halves:

Valve size	25mm DN 25	32mm DN32	38mm DN40	51mm DN50	63.5mm DN65	76mm DN80	101.6mm DN100	125mm DN125	150mm DN150
Spanner flats	10mm (0.4")	10mm (0.4")	10mm (0.4")	13mm (0.5")	13mm (0.5")	13mm (0.5")	17mm (0.67")	17mm (0.67")	17mm (0.67")
Recomm.Torque	18Nm (13 lbf-ft)	18Nm (13 lbf-ft)	18Nm (13 lbf-ft)	20Nm (15 lbf-ft)	20Nm (15 lbf-ft)	20Nm (15 lbf-ft)	38Nm (28 lbf-ft)	38Nm (28 lbf-ft)	38Nm (28 lbf-ft)

Study the instructions carefully. The items refer to the parts list and service kits section.
 Handle scrap correctly.
 NC = Normally closed. NO = Normally open. A/A = Air/air activated.

Step 1

1. Press end cap (5) into air cylinder (1).
2. Remove retaining ring (6).

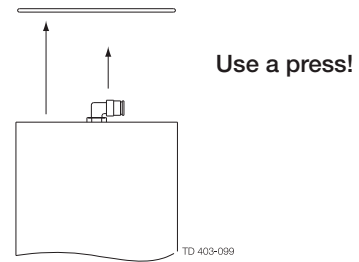

Step 2

NC/NO actuator:

Release the pressure on end cap (5) carefully and remove the end cap.

Pay special attention to the warning!

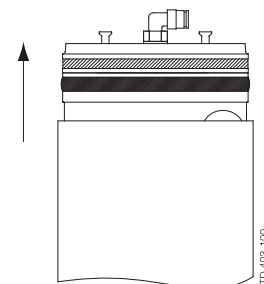

Step 3

A/A actuator:

Remove end cap (5) by hand.

Pay special attention to the warning!

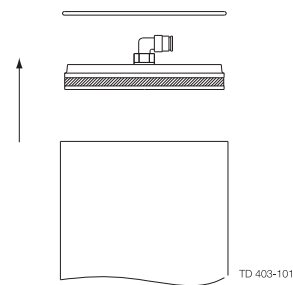

Step 4

Remove piston (3) and the springs.

NOTE!

- The actuator size $\varnothing 133\text{mm}$ has a caged spring assembly.
- The air/air actuator has no springs.

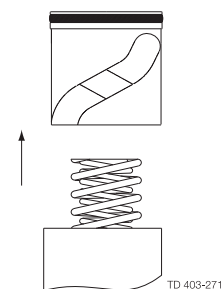

Step 5

Remove connex pin (16) and coupling (17) from rotating cylinder stem (2).

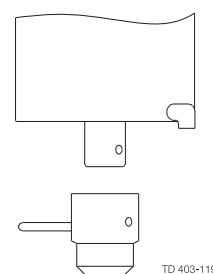

Step 6

Remove rotating cylinder (2) and the remaining internal parts from air cylinder (1).

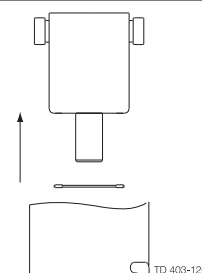

Study the instructions carefully.

NC = Normally closed. NO = Normally open. A/A = Air/air activated.

Lubricate the rubber seals before fitting them. Lubricate the bearings.

Clean the piston before assembly.

Step 1

Fit rotating cylinder (2) in air cylinder (1).

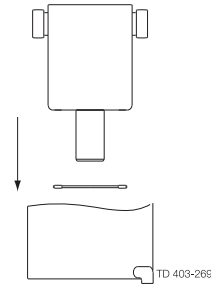

Step 2

Fit coupling (17) on rotating cylinder stem (2) and fit connex pin (16).

Fit the connex pin correctly!

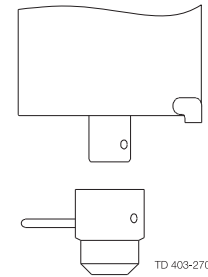

Step 3

Fit the springs in rotating cylinder (2) and fit piston (3) carefully.

CAUTION!

Fit the piston correctly in relation to the bearings.

NOTE!

The air/air actuator is has no springs.

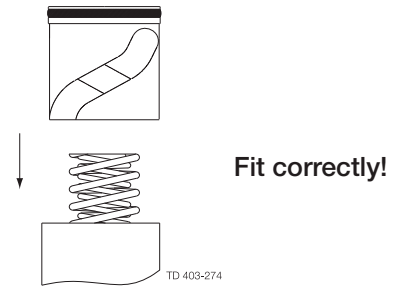

Step 4

A/A actuator:

1. Fit end cap (5) sufficiently into air cylinder (1) so that retaining ring (6) can be fitted in the air cylinder.
2. Position the end cap correctly by hand.

Pay special attention to the warning!

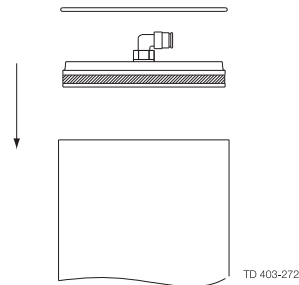

Step 5

1. Fit end cap (5) in air cylinder (1) and press sufficiently down so that retaining ring (6) can be fitted in the air cylinder.
2. Release the pressure on the end cap.

Pay special attention to the warning!

Use a press!
NC/NO actuator

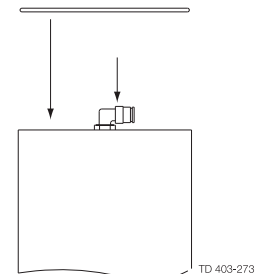

Step 6

Pre-use check:

1. Supply compressed air to the actuator.
2. Activate the actuator several times to ensure that it operates smoothly.

Pay special attention to the warnings!

It is important to observe the technical data during installation, operation and maintenance.

Inform the personnel about the technical data.

NC = Normally closed. NO = Normally open. A/A = Air/air activated.

Valve - data	
Max. product pressure.....	1000kPa (10bar) (145 psi)
Min. product pressure.....	Full vacuum
Temperature range	-10° C to +95° C (14°F to 203°F)
Product acc. to PED 97/23/EC	Fluids group 2
Valve - materials	
Product wetted steel parts.....	AISI 304 or AISI 316L
Other steel parts.....	AISI 304
Rubber grades	EPDM, Silicone (Q), Viton (FPM), HNBR, PFA
Bushes for valve disc.....	PVDF
Finish.....	Semi bright
Actuator - data	
Max. air pressure	700kPa (7bar) (101.5 psi)
Min. air pressure, NC or NO.....	400kPa (4bar) (58 psi)
Temperature range	-25° C to +90° C (-13°F to + 94°F)
Air consumption (litres free air) - ø85 mm	0.24 x p (bar)
- ø133 mm	0,95 x p (bar)
Actuator - materials	
Actuator body.....	AISI 304
Piston.....	Light alloy, bronze for ø85mm A/A
Seals	Nitrile (NBR)
Housing for switches	Noryl (PPO)
Finish.....	Semi bright

Noise

One meter away from - and 1.6 meter above the exhaust the noise level of a valve actuator will be approximately 77db(A) without noise damper and approximately 72 db(A) with damper - Measured at 7 bars air-pressure.

The drawings include all parts of the valves.
For parts list, please see section 6.5 - 6.7

LKB/LKB-2

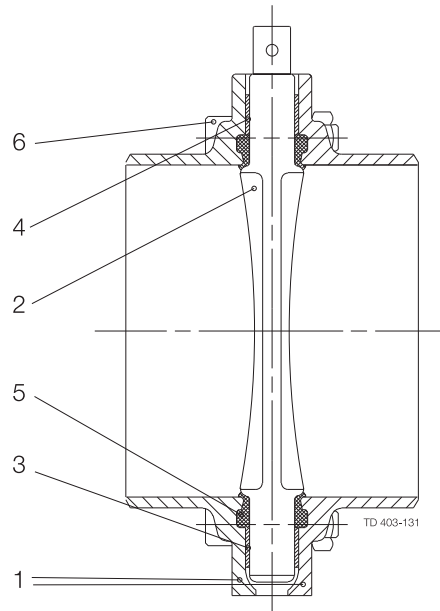

LKB-F

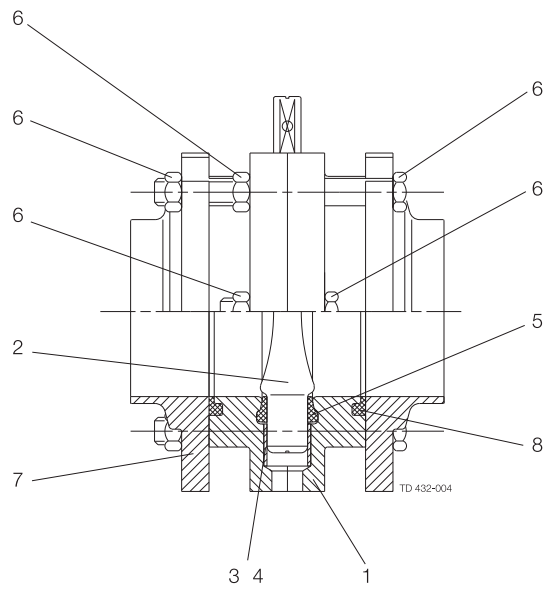

*The drawings include all parts of the actuators.
For parts list, please see section 6.8.*

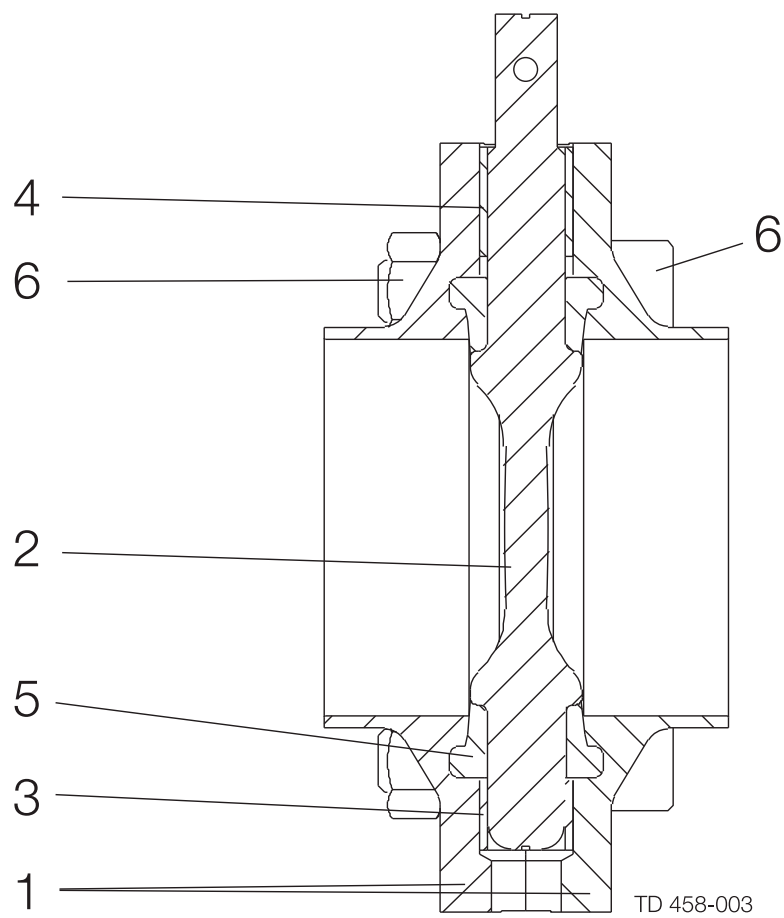

The drawings include all parts of the actuators.
For parts list, please see section 6.9 - 6.18.

LKLA-T (NC-NO)

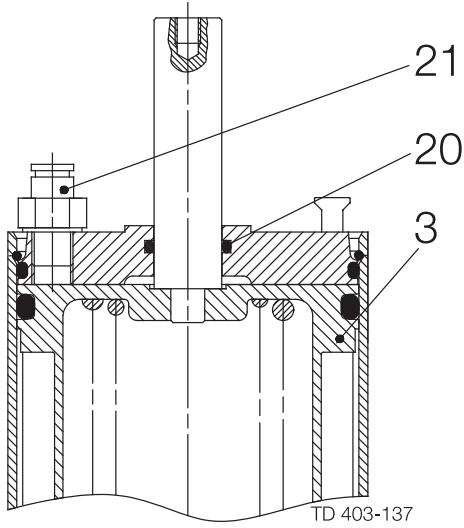

LKLA-T (A/A)

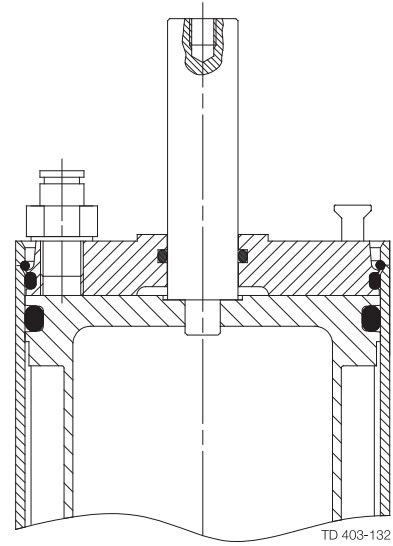

LKLA (NC-NO)

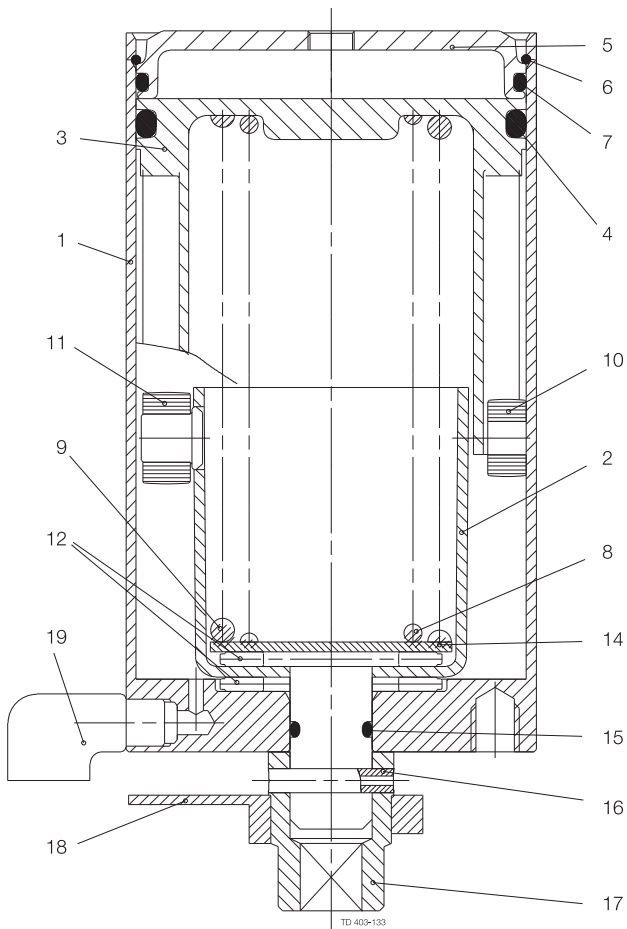

LKLA (A/A)

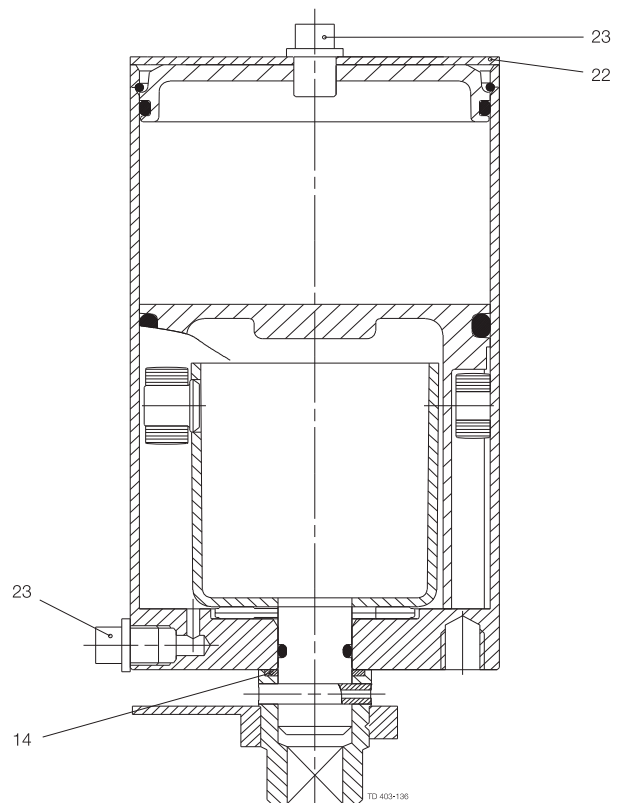

DN 125-150 (A/A)

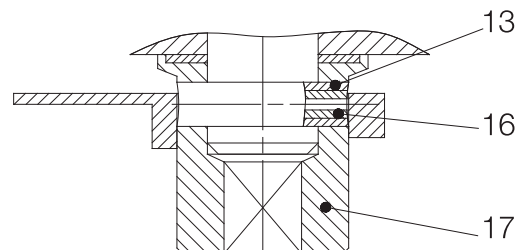

The drawings include all parts of the actuators.
For parts list, please see section 6.9 - 6.18.

LKLA-T (NC-NO)

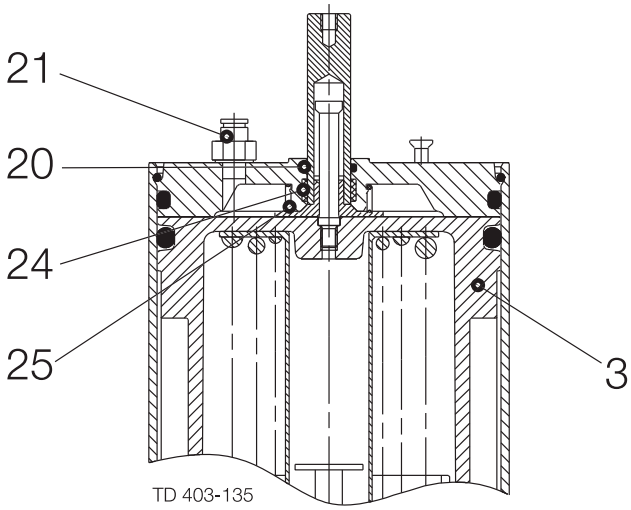

LKLA-T (A/A)

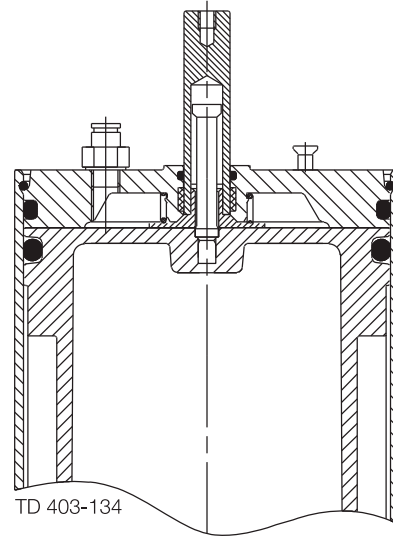

LKLA (NC-NO)

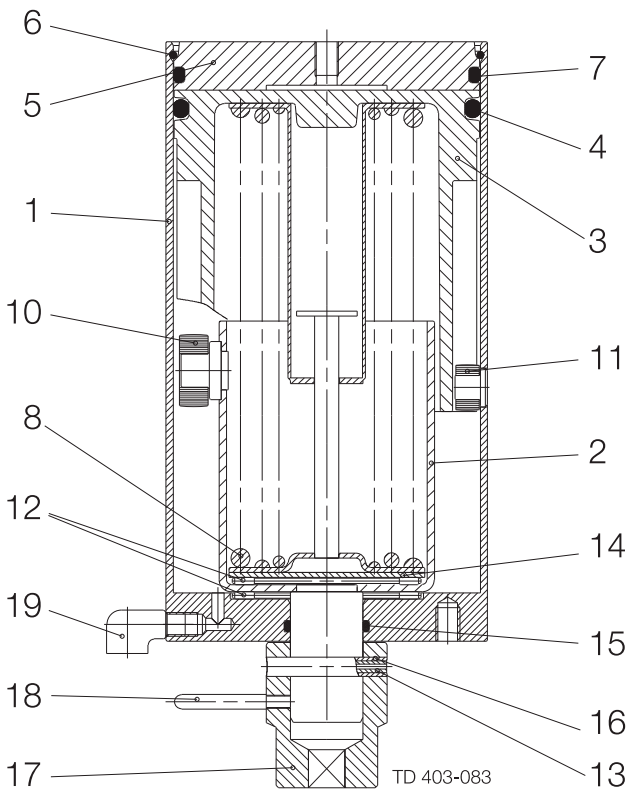

LKLA (A/A)

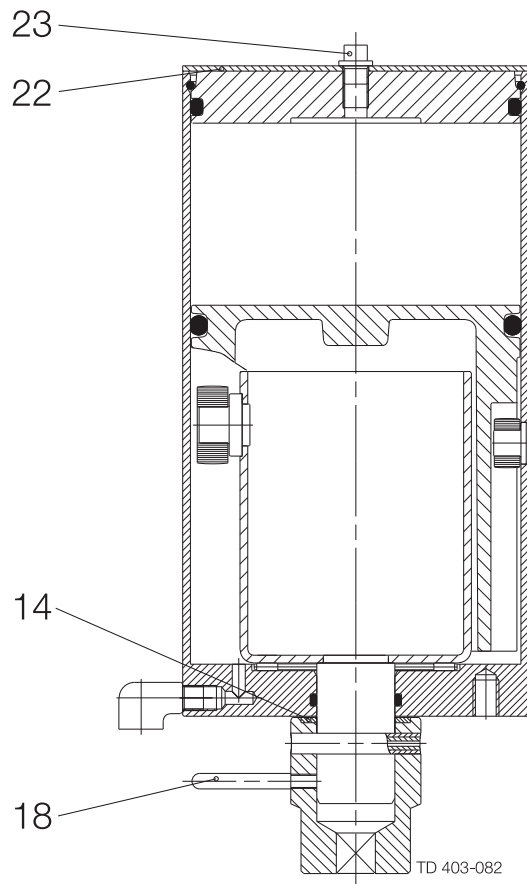

The drawings show all items of the valves.

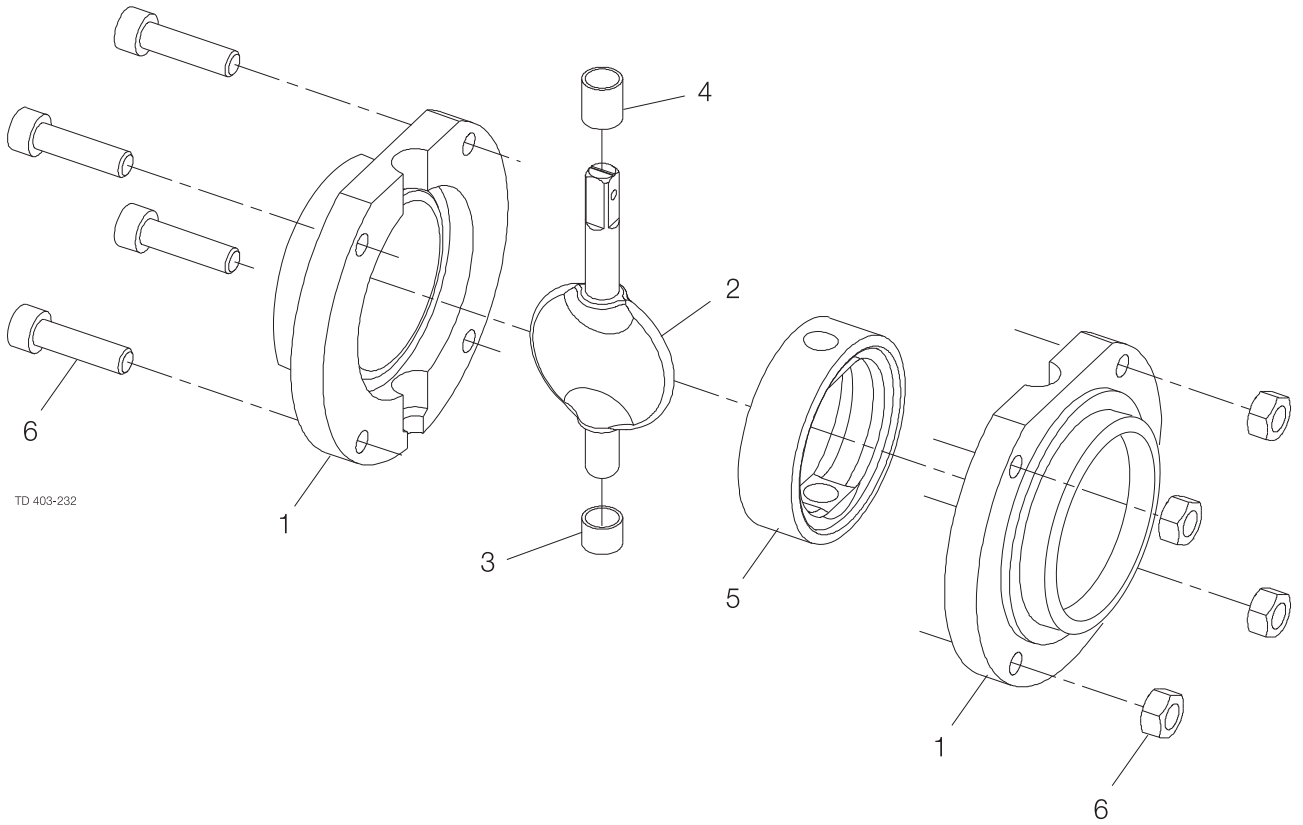

TD 403-232

The drawing and parts list include all items.

Parts List for LKB

Pos.	Qty.	Denomination
1	2	Valve body half, welding
1a	2	Valve body half, male
2	1	Valve disc
3 Δ	1	Bush
4 Δ	1	Bush
5 Δ	1	Seal ring
6	1	Set of screws and nuts

Δ: Service Kit - EPDM, Q, FPM, HNBR, PFA
(See Spare Parts List)

Service Kits for LKB

Denomination	Item number
Product wetted parts	
□ 8 - 25mm/DN 25	
EPDM.....	9611-92-3028
Q.....	9611-92-3034
FPM.....	9611-92-3040
HNBR.....	9611-92-3160
□ 8 - 38mm/DN 40	
EPDM.....	9611-92-3029
Q.....	9611-92-3035
FPM.....	9611-92-3041
HNBR.....	9611-92-3161
PFA.....	9611-92-3183
□ 8 - 51mm/DN 50	
EPDM.....	9611-92-3030
Q.....	9611-92-3036
FPM.....	9611-92-3042
HNBR.....	9611-92-3162
PFA.....	9611-92-3184
□ 8 - 63.5mm/DN 65	
EPDM.....	9611-92-3031
Q.....	9611-92-3037
FPM.....	9611-92-3043
HNBR.....	9611-92-3163
PFA.....	9611-92-3185
□ 10 - 76mm	
EPDM.....	9611-92-3032
Q.....	9611-92-3038
FPM.....	9611-92-3044
HNBR.....	9611-92-3164
PFA.....	9611-92-3186
□ 10 - DN 80	
EPDM.....	9611-92-3051
□ 10 - □ 12 - 101.6mm/DN 100	
EPDM.....	9611-92-3033
Q.....	9611-92-3039
FPM.....	9611-92-3045
HNBR.....	9611-92-3165
PFA.....	9611-92-3187
□ 15 - DN 150	
EPDM.....	9611-92-3046
Q.....	9611-92-3047
FPM.....	9611-92-3048
HNBR.....	9611-92-3197

The drawings show all items of the valves.

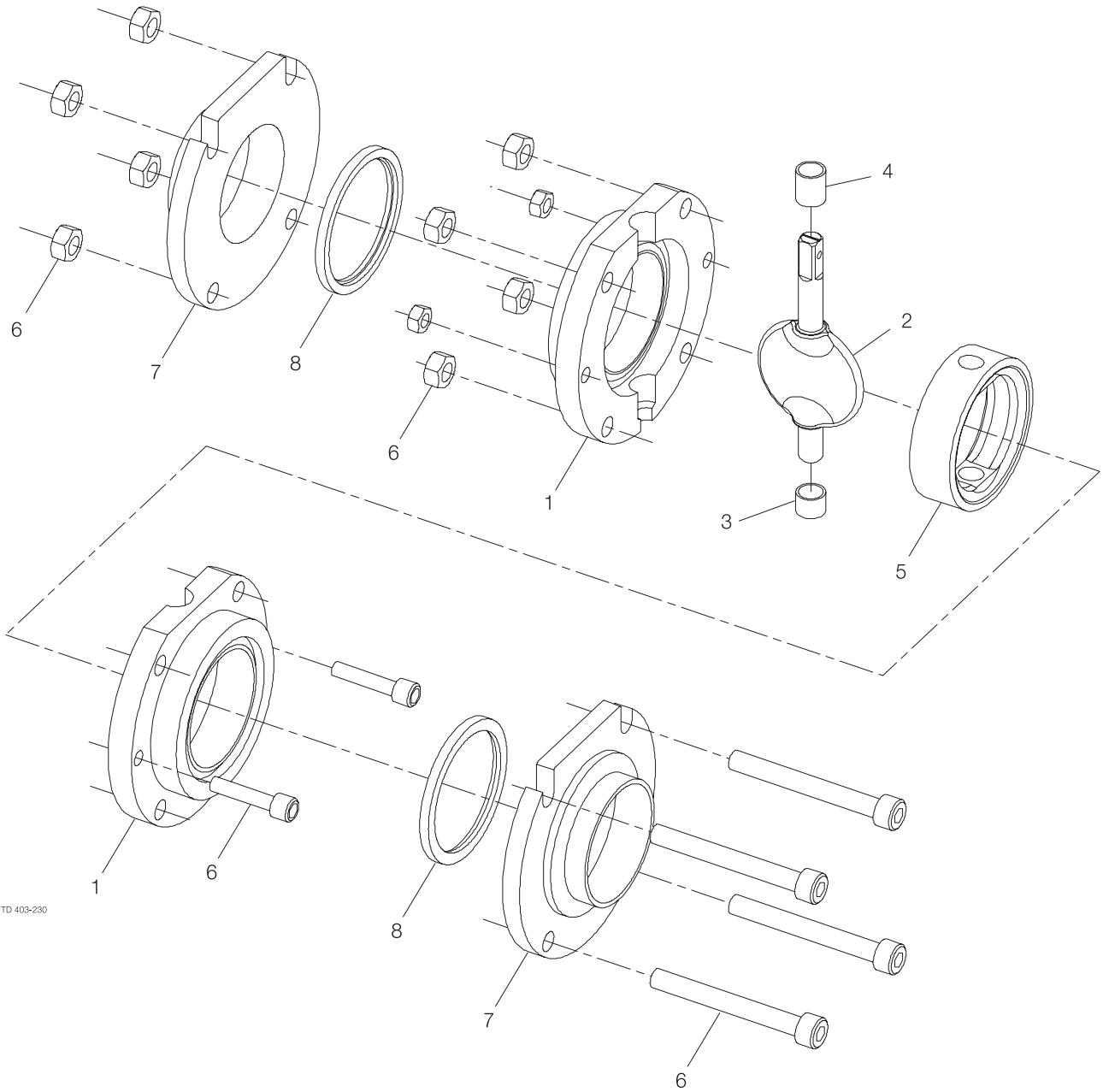

TD 408-230

The drawing and parts list include all items.

Parts List for LKB-F

Pos.	Qty.	Denomination
1	2	Valve body half, welding
1a	2	Valve body half, male
2	1	Valve disc
3 Δ	1	Bush
4 Δ	1	Bush
5 Δ	1	Seal ring
6	1	Set of screws and nuts
7	2	Flange
8 Δ	2	Flange seal ring

Δ: Service Kit - EPDM, Q, FPM, HNBR, PFA
(See Spare Parts List)

Service Kits for LKB-F - ISO

Denomination	Item number
Product wetted parts	
25mm	
EPDM.....	9611-92-3058
Q.....	9611-92-3064
FPM.....	9611-92-3070
38mm	
EPDM.....	9611-92-3059
Q.....	9611-92-3065
FPM.....	9611-92-3071
51mm	
EPDM.....	9611-92-3060
Q.....	9611-92-3066
FPM.....	9611-92-3072
63.5mm	
EPDM.....	9611-92-3061
Q.....	9611-92-3067
FPM.....	9611-92-3073
76mm	
EPDM.....	9611-92-3062
Q.....	9611-92-3068
FPM.....	9611-92-3074
101.6mm	
EPDM.....	9611-92-3063
Q.....	9611-92-3069
FPM.....	9611-92-3099

Service Kits for LKB-F - DIN

Denomination	Item number
Product wetted parts	
25mm	
EPDM.....	9611-92-3100
Q.....	9611-92-3109
FPM.....	9611-92-3118
38mm	
EPDM.....	9611-92-3101
Q.....	9611-92-3110
FPM.....	9611-92-3119
DN 40	
EPDM.....	9611-92-3102
Q.....	9611-92-3111
FPM.....	9611-92-3120
DN 50	
EPDM.....	9611-92-3103
Q.....	9611-92-3112
FPM.....	9611-92-3121
DN 65	
EPDM.....	9611-92-3104
Q.....	9611-92-3113
FPM.....	9611-92-3122
DN 80	
EPDM.....	9611-92-3105
Q.....	9611-92-3114
FPM.....	9611-92-3123
DN 100	
EPDM.....	9611-92-3106
Silicone (Q).....	9611-92-3115
FPM.....	9611-92-3124
DN 125	
EPDM.....	9611-92-3107
Silicone (Q).....	9611-92-3116
FPM.....	9611-92-3125
DN 150	
EPDM.....	9611-92-3108
Silicone (Q).....	9611-92-3117
FPM.....	9611-92-3126

The drawings show all items of the valves.

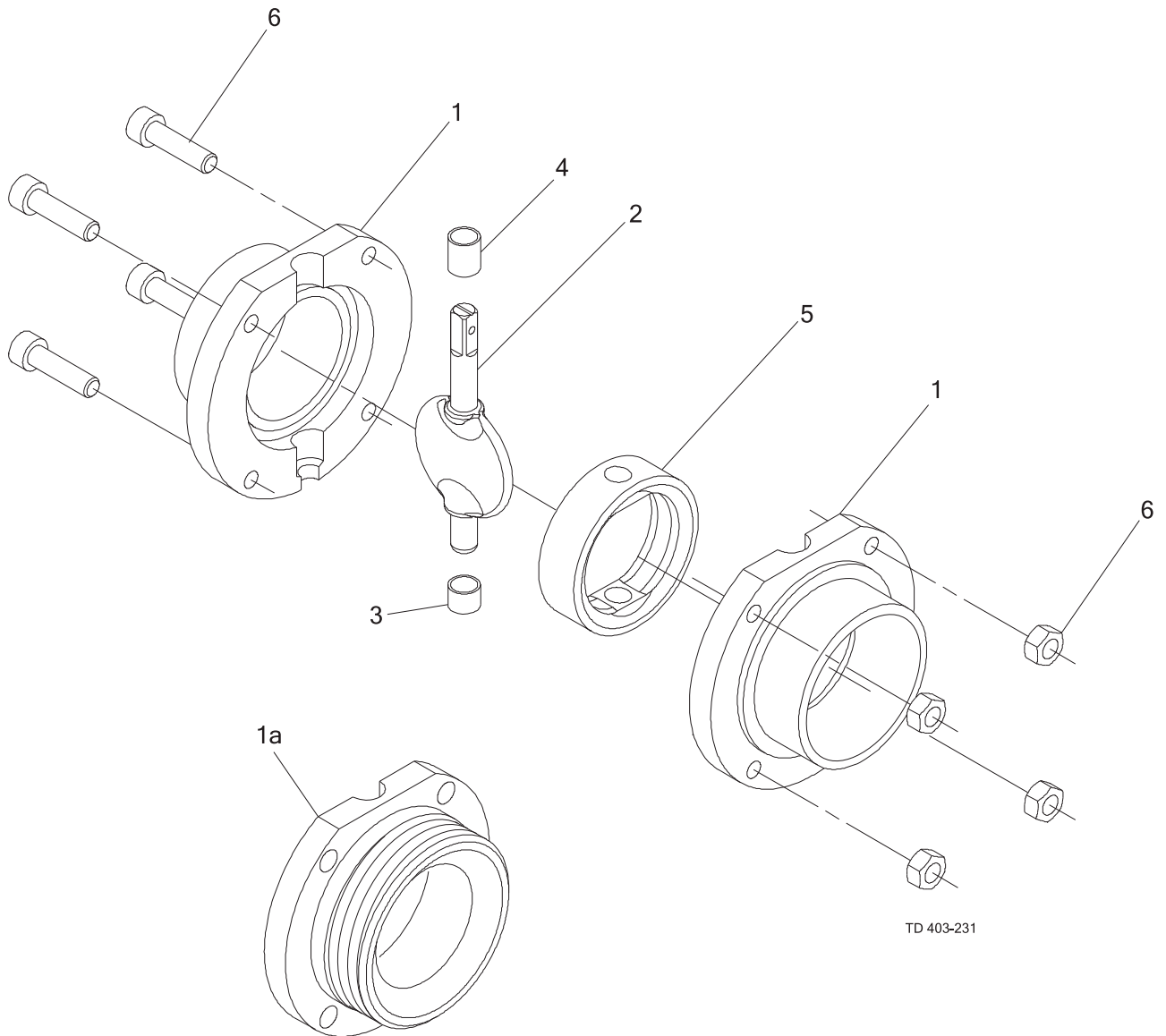

TD 403-231

The drawing and parts list include all items.

Parts List for LKB-2

Pos.	Qty.	Denomination
1	2	Valve body half, welding
1a	2	Valve body half, male
2	1	Valve disc
3 Δ	1	Bush
4 Δ	1	Bush
5 Δ	1	Seal ring
6	1	Set of screws and nuts

Δ: Service Kit - EPDM, Q, FPM, HNBR, PFA
(See Spare Parts List)

Service Kits for LKB-2

Denomination	Item number
□ 8 - DN 25	
EPDM.....	.9611-92-3075
Q.....	.9611-92-3083
FPM.....	.9611-92-3091
HNBR.....	.9611-92-3210
□ 8 - DN 32	
EPDM.....	.9611-92-3076
Q.....	.9611-92-3084
FPM.....	.9611-92-3092
HNBR.....	.9611-92-3211
□ 8 - DN 40	
EPDM.....	.9611-92-3077
Q.....	.9611-92-3085
FPM.....	.9611-92-3093
HNBR.....	.9611-92-3212
PFA.....	.9611-92-3191
□ 8 - DN 50	
EPDM.....	.9611-92-3078
Q.....	.9611-92-3086
FPM.....	.9611-92-3094
HNBR.....	.9611-92-3213
PFA.....	.9611-92-3192
□ 10 - DN 65	
EPDM.....	.9611-92-3079
Q.....	.9611-92-3087
FPM.....	.9611-92-3095
HNBR.....	.9611-92-3214
PFA.....	.9611-92-3193
□ 10 - DN 80	
EPDM.....	.9611-92-3080
Q.....	.9611-92-3088
FPM.....	.9611-92-3096
HNBR.....	.9611-92-3215
PFA.....	.9611-92-3194
□ 12 - DN 100	
EPDM.....	.9611-92-3081
Q.....	.9611-92-3089
FPM.....	.9611-92-3097
HNBR.....	.9611-92-3216
PFA.....	.9611-92-3195
□ 14 - DN 125	
EPDM.....	.9611-92-3082
Q.....	.9611-92-3090
FPM.....	.9611-92-3098
HNBR.....	.9611-92-3217

The drawings show all items of the valves.

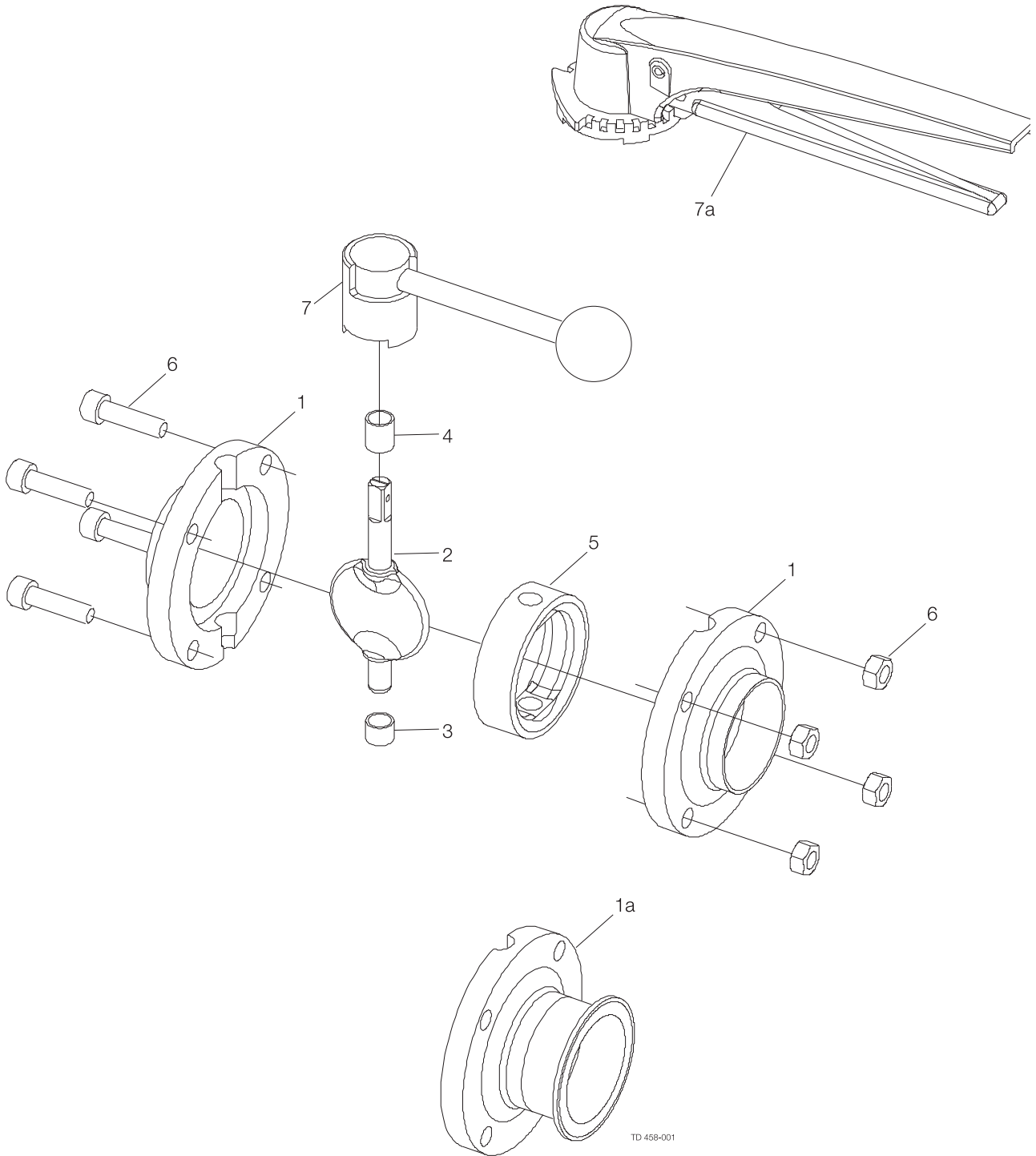

TD 458-001

The drawing and parts list include all items.

Parts List for LKB-LP

Pos.	Qty.	Denomination
1	2	Valve body half, clamp
1a	2	Valve body half, welding
2	1	Disc
3 Δ	1	Bush
4 Δ	1	Bush
5 Δ	1	Sealring (EPDM)
6	1	Set screw
7	1	Handle

Service Kits for LKB-LP ISO

Denomination	Item number
25mm	
EPDM.....	9611-92-3028
38mm	
EPDM.....	9611-92-3204
51mm	
EPDM.....	9611-92-3205
63.5mm	
EPDM.....	9611-92-3031
76.1 mm	
EPDM.....	9611-92-3032
101.6	
EPDM.....	9611-92-3033

Service Kits for LKB-LP DIN

Denomination	Item number
DN25	
EPDM.....	9611-92-3206
DN40	
EPDM.....	9611-92-3207
DN50	
EPDM.....	9611-92-3208
DN65	
EPDM.....	9611-92-3079
DN80	
EPDM.....	9611-92-3209
DN100	
EPDM.....	9611-92-3210

The drawings show all items of the valves.

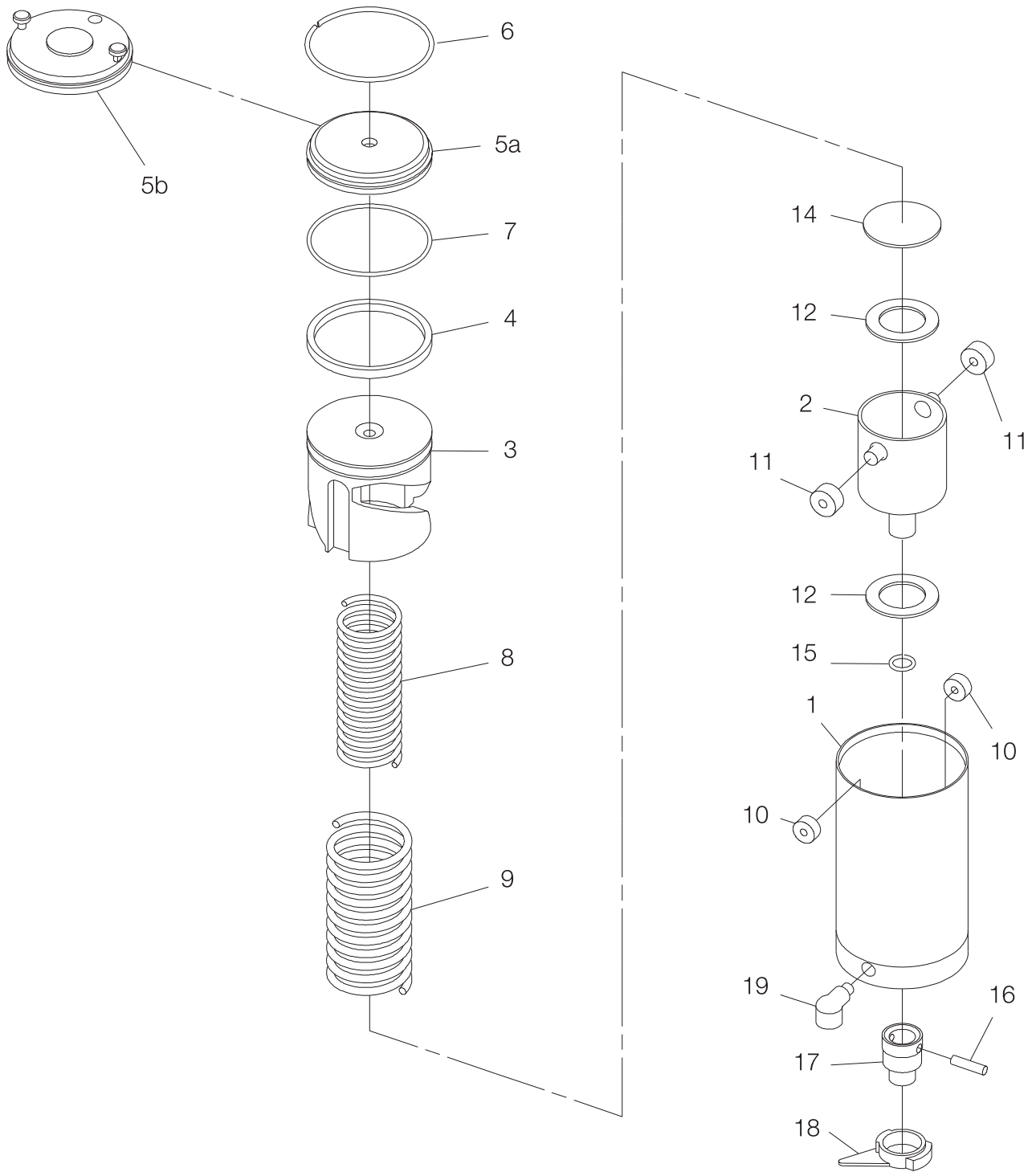

TD 407-025

The drawing and the parts list include all items.
 NO = Normally open.
 NC = Normally closed.

Parts List			Service Kits LKLA ø85 mm (NO/NC)	
Pos.	Qty.	Denomination	Denomination	Item number
1	1	Air cylinder		
2	1	Rotating cylinder	Actuator	
3	1	Piston	LKLA NO/NC	
4 Δ	1	O-ring, NBR	Kit	9611-92-3010
5a	1	End cap (Period 0011-)		
6	1	Retaining ring	Δ: Service kits - actuator	
7 Δ	1	O-ring, NBR		
8	1	Inner spring		
9	1	Outer spring		
10Δ	2	Needle bearing		
11Δ	2	Needle bearing		
12Δ	2	Thrust bearing		
14	1	Thrust plate		
15Δ	1	O-ring, NBR		
16	1	Connex pin		
17	1	Coupling		
18	1	Activating ring, Noryl with screw		
19	1	Water rejector (Period 8310-)		

The drawings show all items of the valves.

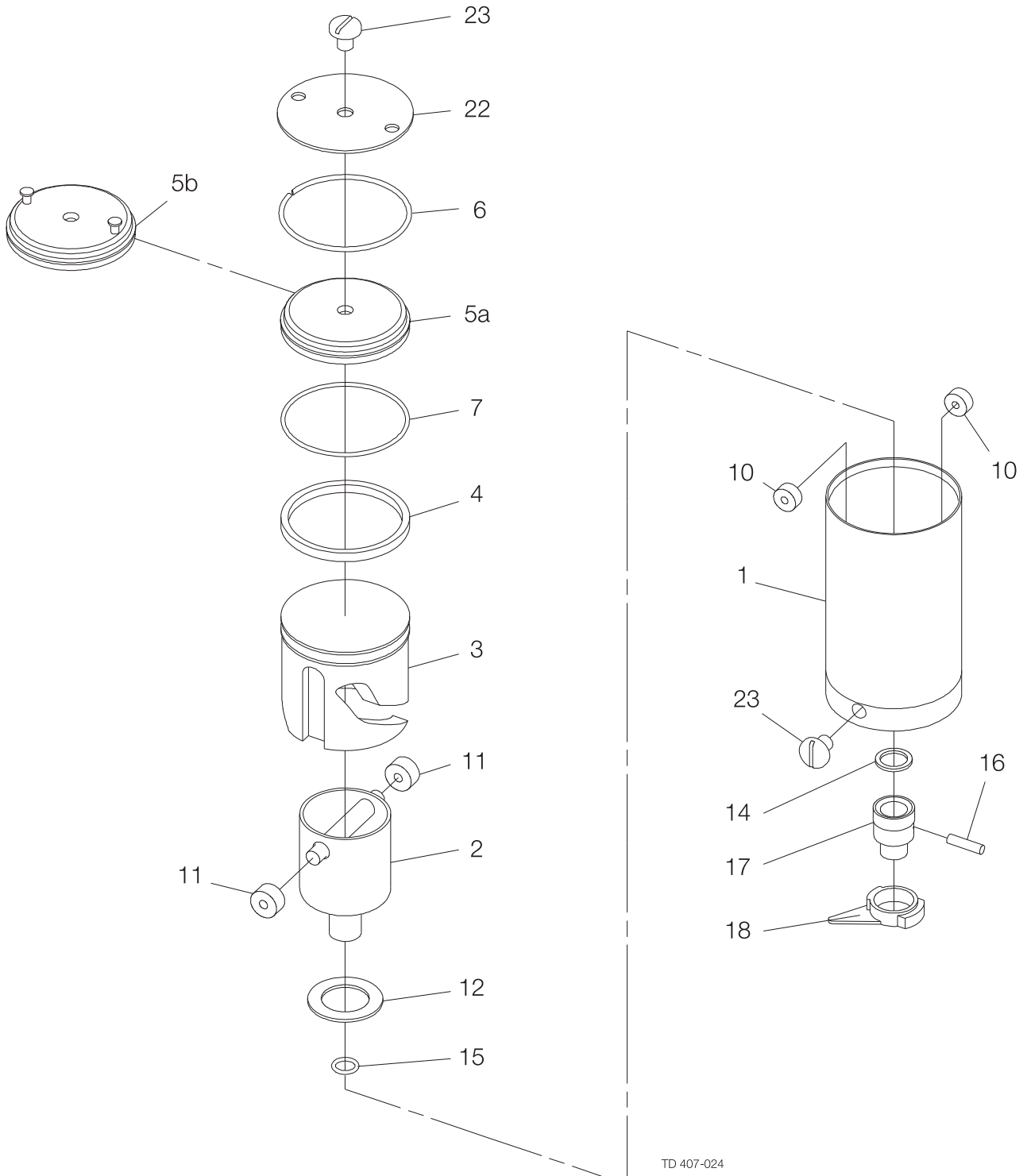

TD 407-024

The drawing and parts list include all items.

Parts List			Service Kits LKLA ø85 mm (A/A)	
Pos.	Qty.	Denomination	Denomination	Item number
1	1	Air Cylinder	Actuator	
2	1	Rotating cylinder	LKLA A/A	
3	1	Piston	Kit	9611-92-3011
4 Δ	1	O-ring, NBR		
5a	1	End cap (Period 0011-)	Δ: Service kits - actuator	
6	1	Retaining ring		
7 Δ	1	O-ring, NBR		
10Δ	2	Needle bearing		
11Δ	2	Needle bearing		
12Δ	1	Thrust bearing		
13	1	Connex pin		
14	1	Thrust plate		
15Δ	1	O-ring, NBR		
16	1	Connex pin		
17	1	Coupling		
18	1	Activating ring with screw		
22***	1	Retaining plate		
23	2	Threaded plug		

The drawings show all items of the valves.

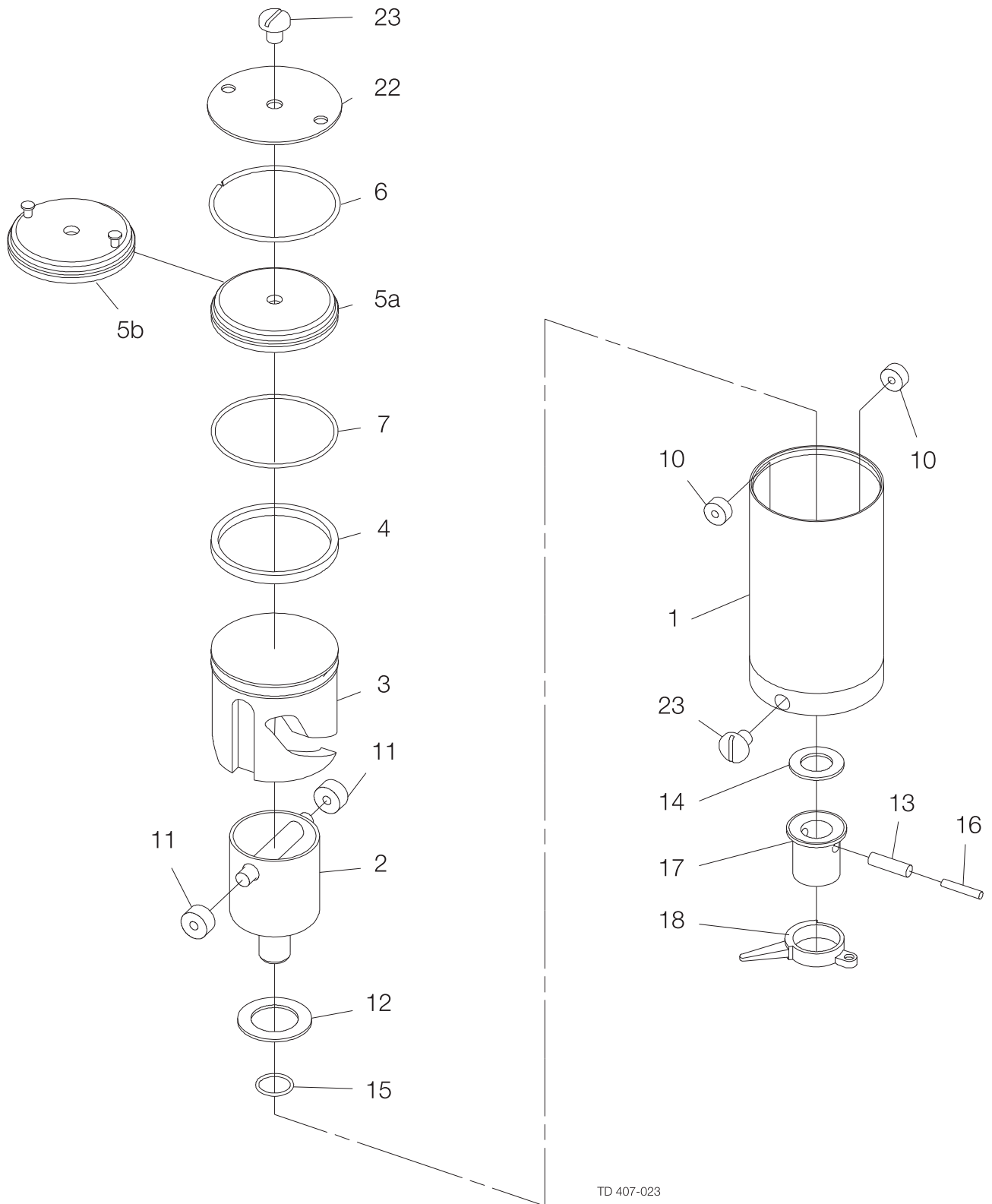

The drawing and parts list include all items.

Parts List			Service Kits LKLA DN125-150 ø85 mm (A/A)	
Pos.	Qty.	Denomination	Denomination	Item number
1	1	Air Cylinder	Actuator	
2	1	Rotating cylinder	LKLA A/A	
3	1	Piston	Kit	9611-92-3012
4 Δ	1	O-ring, NBR		
5a	1	End cap (Period 0011-)	Δ: Service kits - actuator	
6	1	Retaining ring		
7 Δ	1	O-ring, NBR		
10Δ	2	Needle bearing		
11Δ	2	Needle bearing		
12Δ	1	Thrust bearing		
13	1	Connex pin		
14	1	Thrust plate		
15Δ	1	O-ring, NBR		
16	1	Connex pin		
17	1	Coupling		
18	1	Activating ring with screw		
22***	1	Retaining plate		
23	2	Threaded plug		

The drawings show all items of the valves.

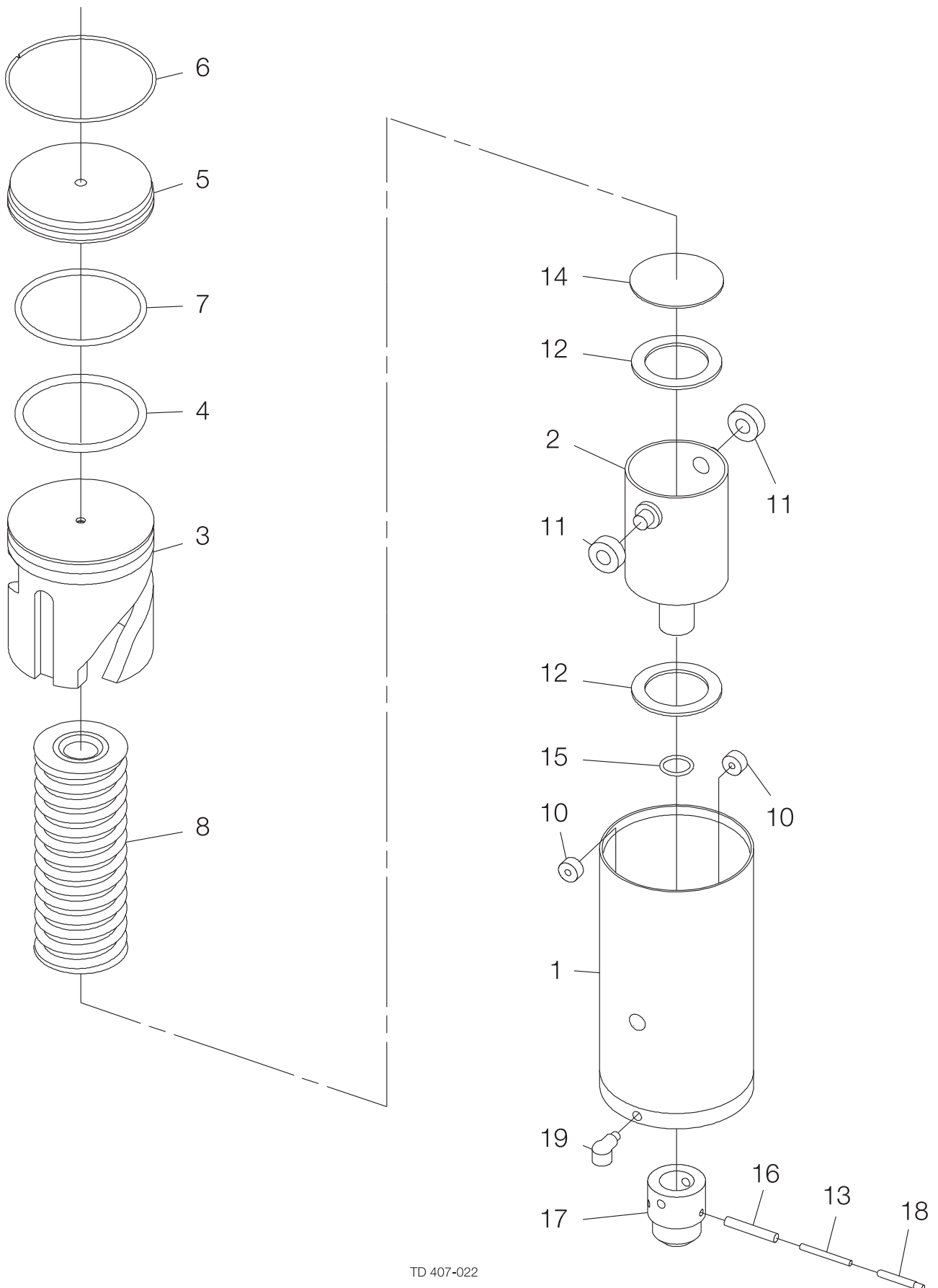

TD 407-022

The drawing and the parts list include all items.
 NO = Normally open.
 NC = Normally closed.

Parts List			Service Kits LKLA ø133 mm (NO/NC)	
Pos.	Qty.	Denomination	Denomination	Item number
1	1	Air cylinder	Actuator	
2	1	Rotating cylinder	LKLA NO/NC	
3	1	Piston	Kit	9611-92-3020
4 Δ	1	O-ring, NBR		
5	1	End cap (Period: 0011-)		
6	1	Retaining ring		
7 Δ	1	O-ring, NBR	Δ: Service kits - actuator	
8	1	Spring assembly		
10Δ	2	Needle bearing		
11Δ	2	Needle bearing		
12Δ	2	Thrust bearing		
13	1	Connex pin		
14	1	Thrust plate		
15Δ	1	O-ring, NBR		
16	1	Connex pin		
17	1	Coupling		
18	1	Indication pin		
19	1	Water rejector		

The drawings show all items of the valves.

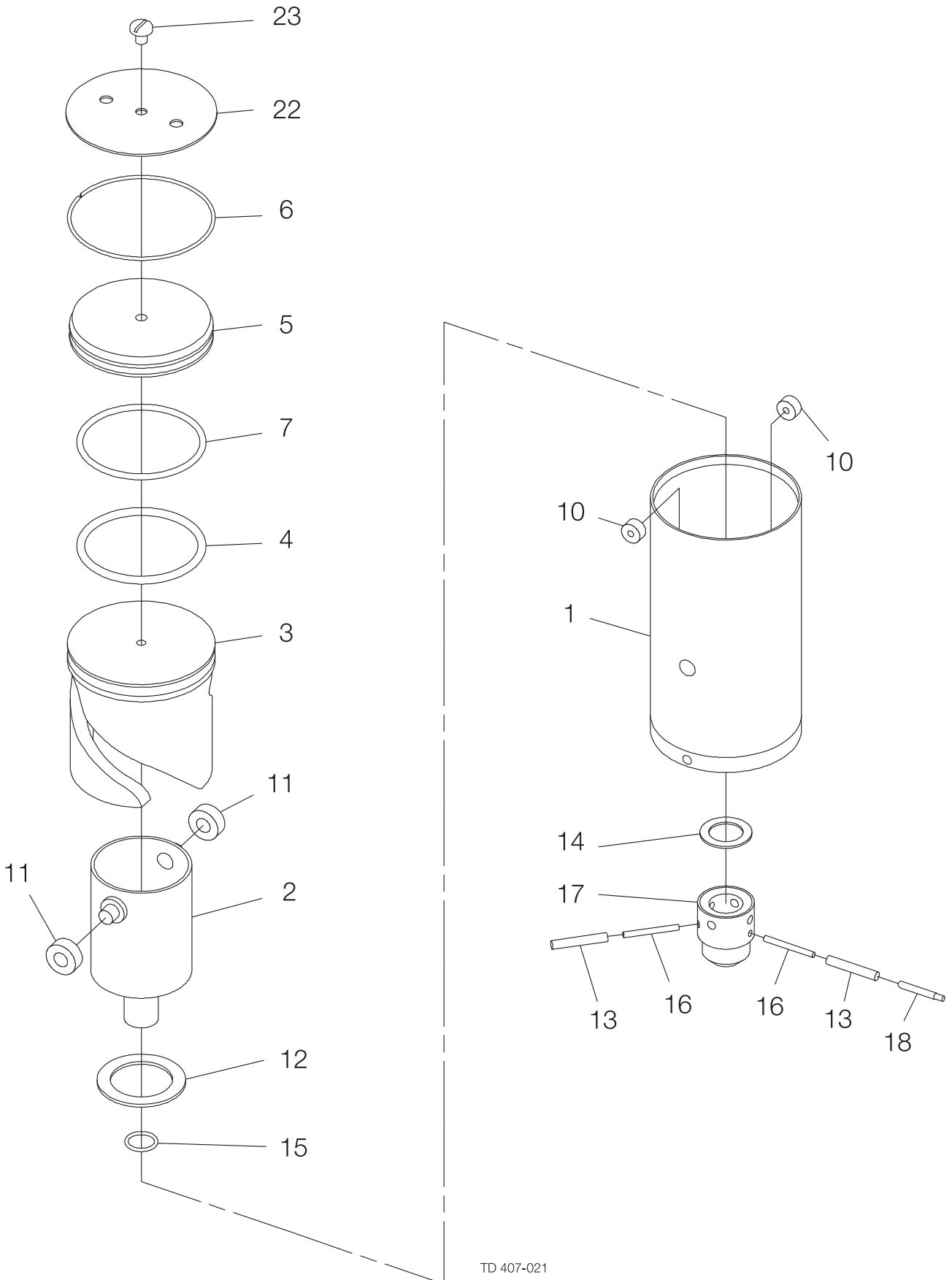

TD 407-021

The drawing and parts list include all items.

Parts List			Service Kits LKLA \varnothing 133 mm (A/A)	
Pos.	Qty.	Denomination	Denomination	Item number
1	1	Air Cylinder	Actuator	
2	1	Rotating cylinder	LKLA A/A	
3	1	Piston	Kit	9611-92-3022
4 Δ	1	O-ring, NBR		
5	1	End cap (Period: 0011-)		
6	1	Retaining ring	Δ : Service kits - actuator	
7 Δ	1	O-ring, NBR		
10 Δ	2	Needle bearing		
11 Δ	2	Needle bearing		
12 Δ	1	Thrust bearing		
13	2	Connex pin		
14	1	Thrust plate		
15 Δ	1	O-ring, NBR		
16	2	Connex pin		
17	1	Coupling		
18	1	Indication pin		
22	1	Retaining plate		
23	1	Threaded plug		

The drawings show all items of the valves.

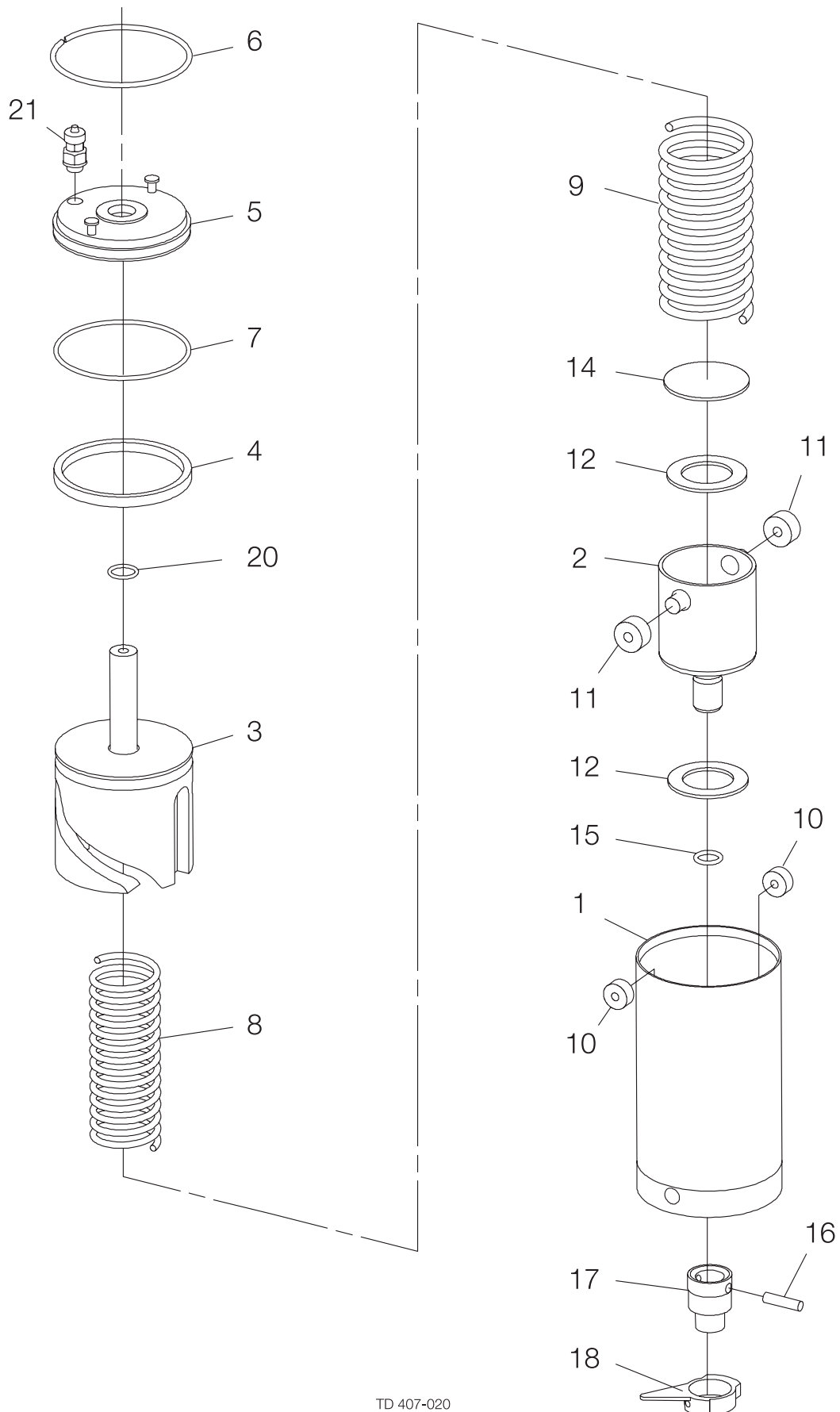

TD 407-020

The drawing and the parts list include all items.
 NO = Normally open.
 NC = Normally closed.

Parts List			Service Kits LKLA-T ø85 mm (NO/NC)	
Pos.	Qty.	Denomination	Denomination	Item number
1	1	Air cylinder	Actuator	
2	1	Rotating cylinder	LKLA-T NO/NC	
3	1	Piston	Kit	9611-92-3021
4 Δ	1	O-ring, NBR		
5	1	End cap	Δ: Service kits - actuator	
6	1	Retaining ring		
7 Δ	1	O-ring, NBR		
8	1	Inner spring		
9	1	Outer spring		
10Δ	2	Needle bearing		
11Δ	2	Needle bearing		
12Δ	2	Thrust bearing		
14	1	Thrust plate		
15Δ	1	O-ring, NBR		
16	1	Connex pin		
17	1	Coupling		
18	1	Activating ring with screw		
20Δ	1	O-ring, NBR		
21	1	Air fitting		

The drawings show all items of the valves.

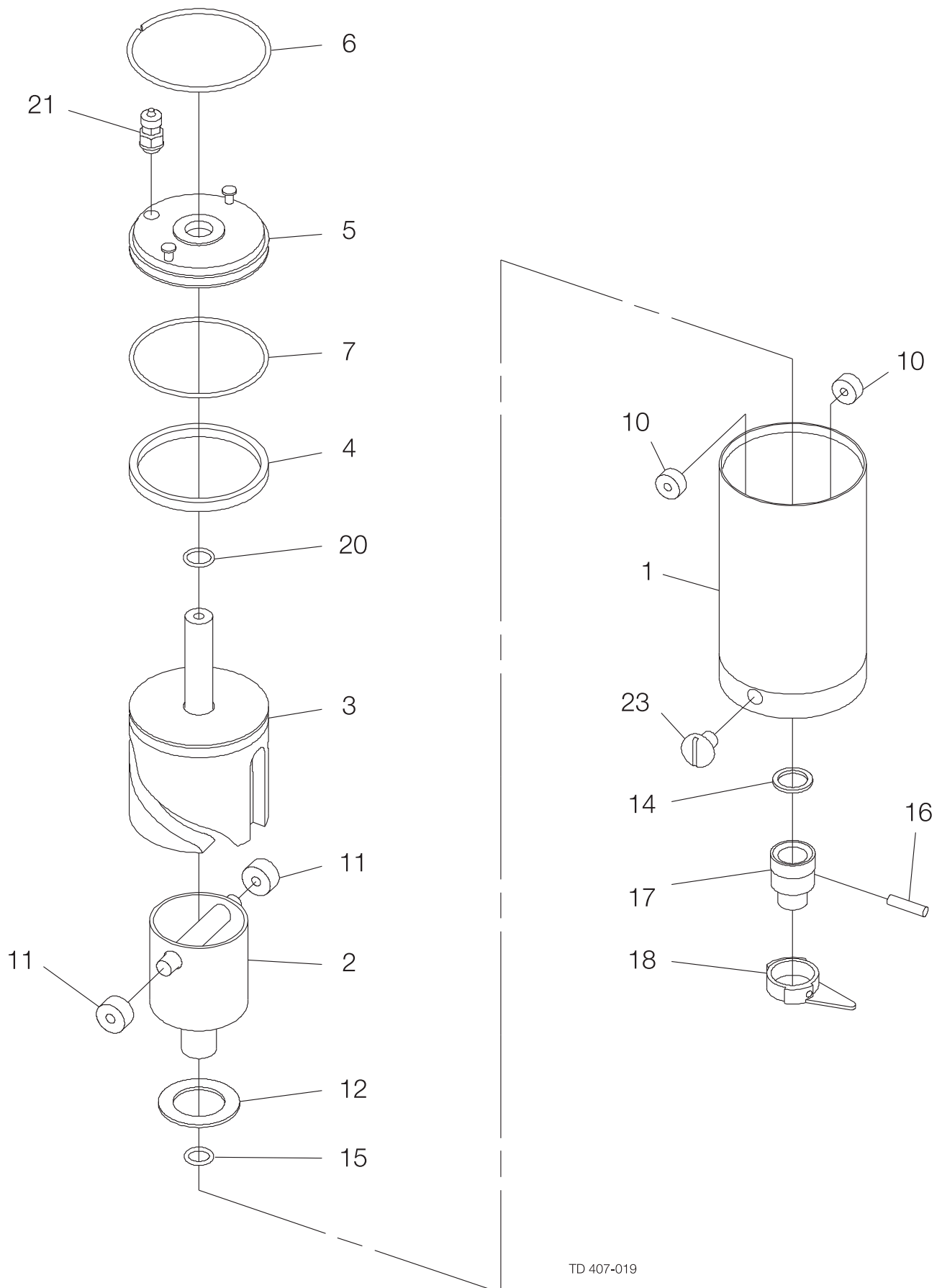

TD 407-019

The drawing and the parts list include all items.

Parts List			Service Kits LKLA-T ø85 mm (A/A)	
Pos.	Qty.	Denomination	Denomination	Item number
11	1	Air cylinder	Actuator	
2	1	Rotating cylinder	LKLA-T A/A	
3	1	Piston	Kit	9611-92-3023
4 Δ	1	O-ring, NBR		
5	1	End cap	Δ: Service kits - actuator	
6	1	Retaining ring		
7 Δ	1	O-ring, NBR		
10Δ	2	Needle bearing		
11Δ	2	Needle bearing		
12Δ	1	Thrust bearing		
14	1	Thrust plate		
15Δ	1	O-ring, NBR		
16	1	Connex pin		
17	1	Coupling		
18	1	Activating ring with screw		
20Δ	1	O-ring, NBR		
21	1	Air fitting		
23	1	Threaded plug		

The drawings show all items of the valves.

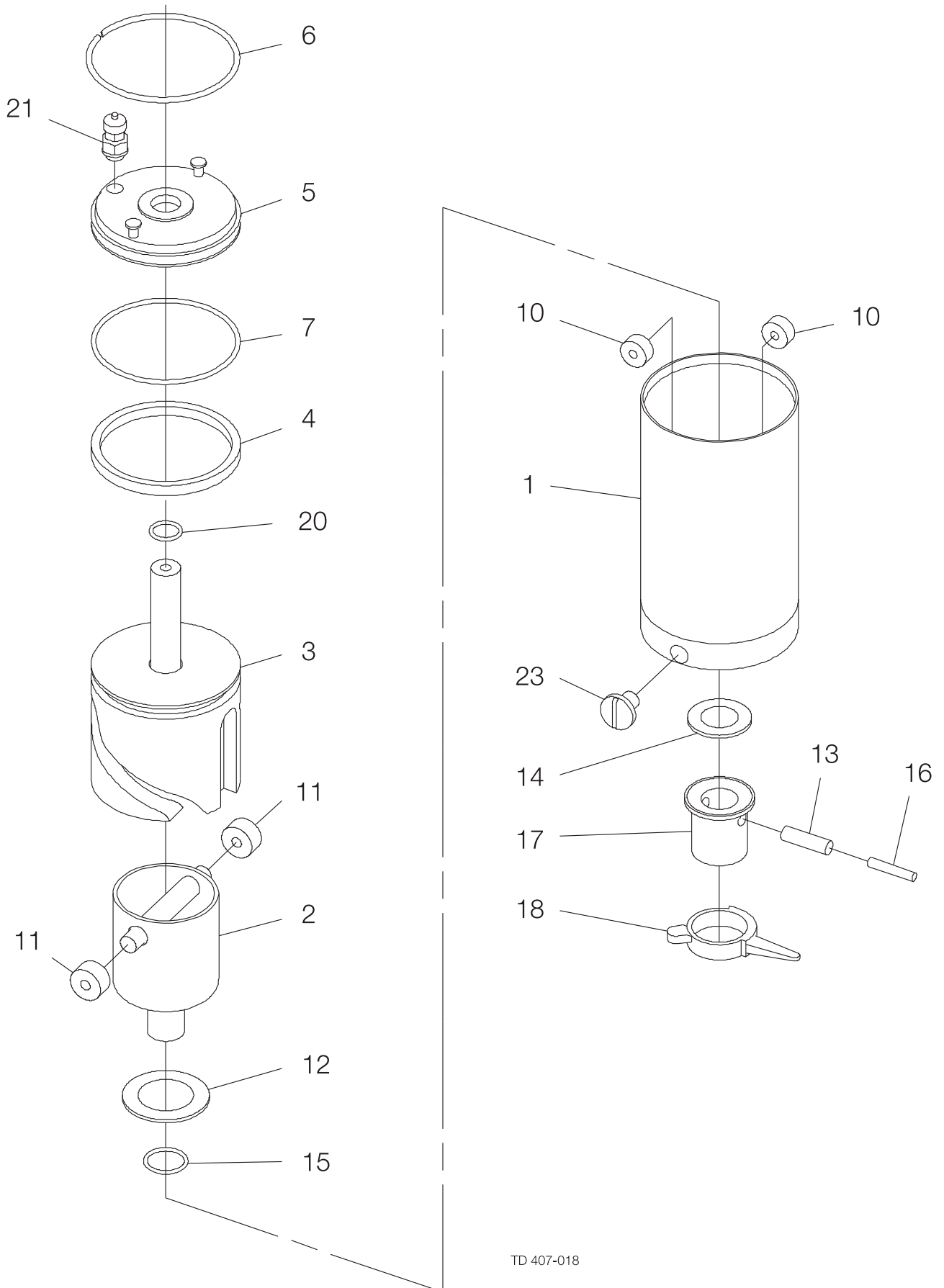

TD 407-018

The drawing and the parts list include all items.

Parts List			Service Kits LKLA-T DN 125-150 ø85 mm (A/A)	
Pos.	Qty.	Denomination	Denomination	Item number
1	1	Air cylinder	Actuator	
2	1	Rotating cylinder	LKLA-T A/A	
3	1	Piston	Kit	9611-92-3024
4 Δ	1	O-ring, NBR		
5	1	End cap	Δ: Service kits - actuator	
6	1	Retaining ring		
7 Δ	1	O-ring, NBR		
10Δ	2	Needle bearing		
11Δ	2	Needle bearing		
12Δ	1	Thrust bearing		
13	1	Connex pin		
14	1	Thrust plate		
15Δ	1	O-ring, NBR		
16	1	Connex pin		
17	1	Coupling		
18	1	Activating ring with screw		
20Δ	1	O-ring, NBR		
21	1	Air fitting		
23	1	Threaded plug		

The drawings show all items of the valves.

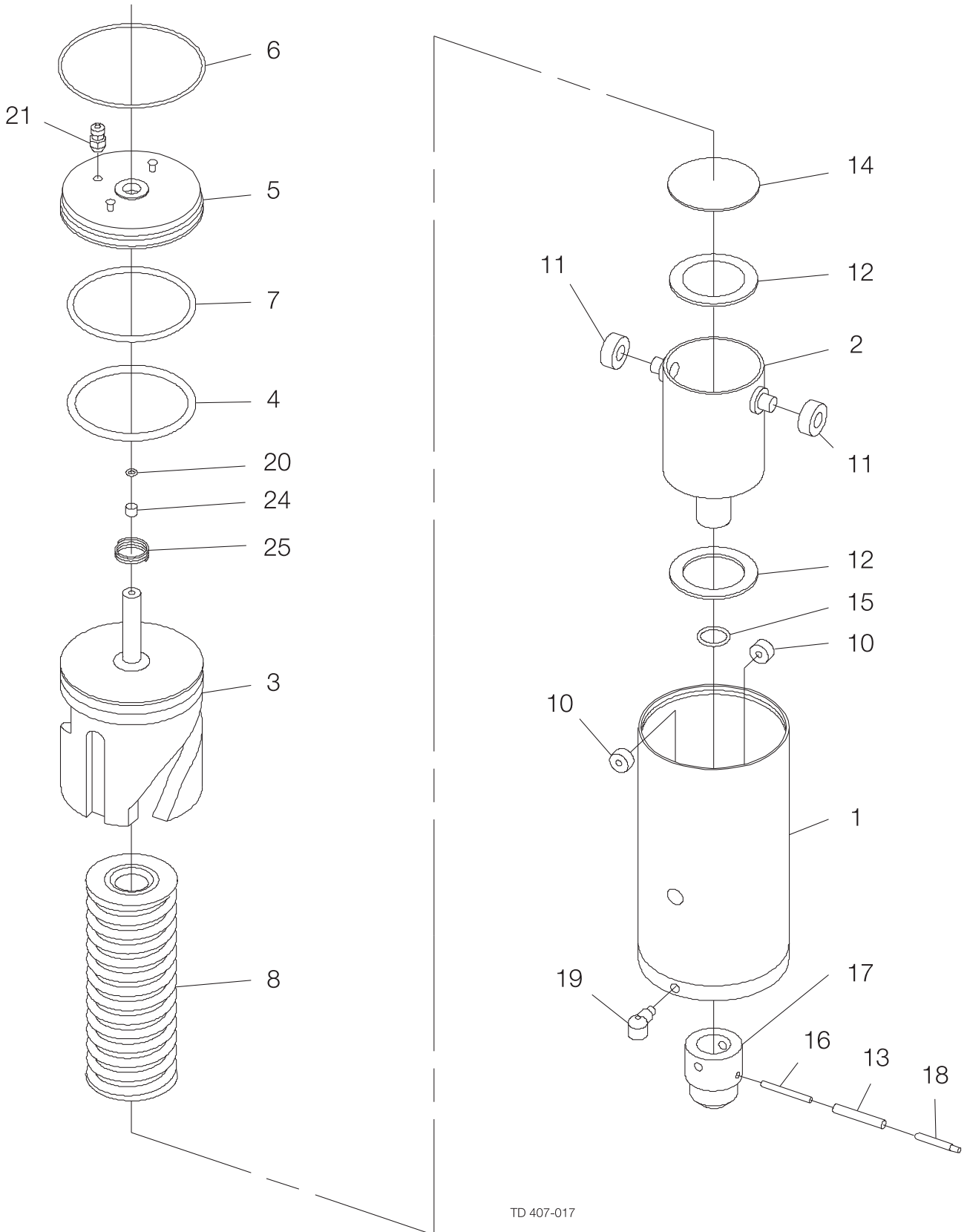

TD 407-017

The drawing and the parts list include all items.
 NO = Normally open.
 NC = Normally closed.

Parts List			Service Kits LKLA-T ø133 mm (NO/NC)	
Pos.	Qty.	Denomination	Denomination	Item number
1	1	Air cylinder	Actuator	
2	1	Rotating cylinder	LKLA-T NO/NC	
3	1	Piston	Kit	9611-92-3056
4 Δ	1	O-ring, NBR		
5	1	End cap	Δ: Service kits - actuator	
6	1	Retaining ring		
7 Δ	1	O-ring, NBR		
8	1	Spring assembly		
10Δ	2	Needle bearing		
11Δ	2	Needle bearing		
12Δ	2	Thrust bearing		
13	1	Connex pin		
14	1	Thrust plate		
15Δ	1	O-ring, NBR		
16	1	Connex pin		
17	1	Coupling		
18	1	Indication pin		
19	1	Water rejector		
20Δ	1	O-ring		
21	1	Air fitting		
24Δ	1	Guiding ring		
25	1	Spring		

The drawing and the parts list include all items.

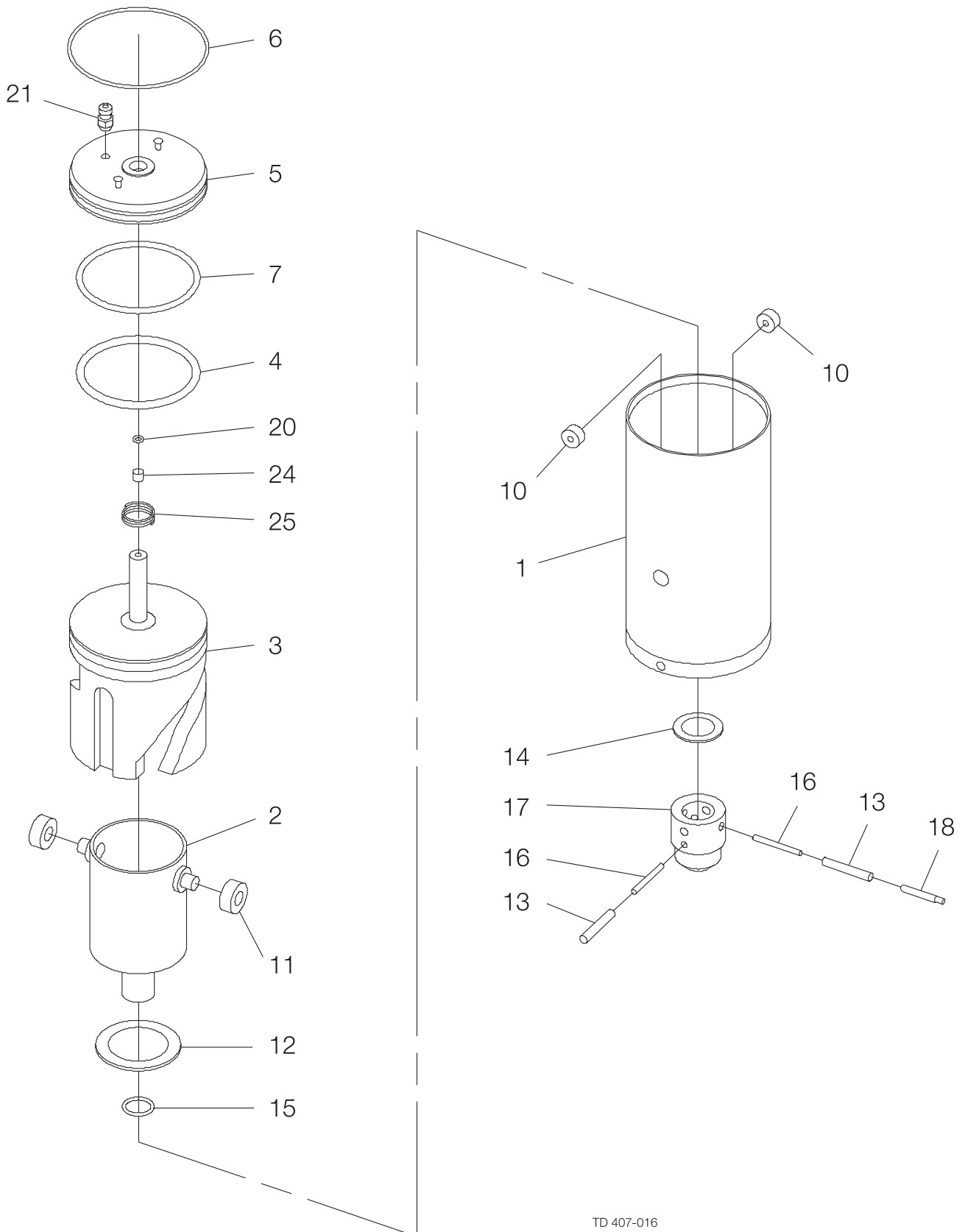

TD 407-016

The drawing and the parts list include all items.

Parts List			Service Kits LKLA-T ø133 mm (A/A)	
Pos.	Qty.	Denomination	Denomination	Item number
1	1	Air cylinder	Actuator	
2	1	Rotating cylinder	LKLA-T A/A	
3	1	Piston	Kit	9611-92-3057
4Δ	1	O-ring, NBR		
5	1	End cap	Δ: Service kits - actuator	
6	1	Retaining ring		
7Δ	1	O-ring, NBR		
10Δ	2	Needle bearing		
11Δ	2	Needle bearing		
12Δ	1	Thrust bearing		
13	2	Connex pin		
14	1	Thrust plate		
15Δ	1	O-ring, NBR		
16	2	Connex pin		
17	1	Coupling		
18	1	Indication pin		
20Δ	1	O-ring, NBR		
21	1	Air fitting		
24Δ	1	Guiding band		
25	1	Spring		

This page shows exploded drawings of the standard handle, the handle for indication unit, the regulating handle and the Lockable Multiposition Handle. The drawings and the parts list include all items.

Standard handle

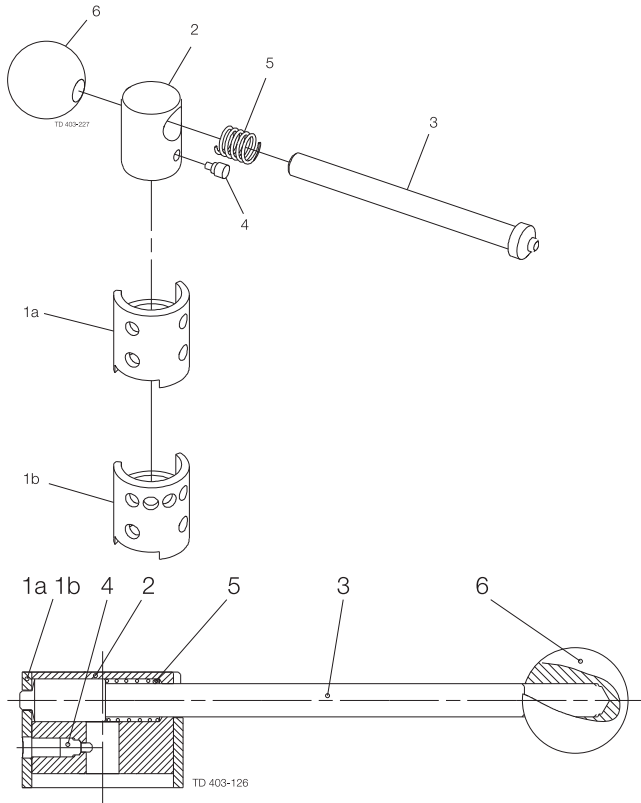

Handle for indication unit

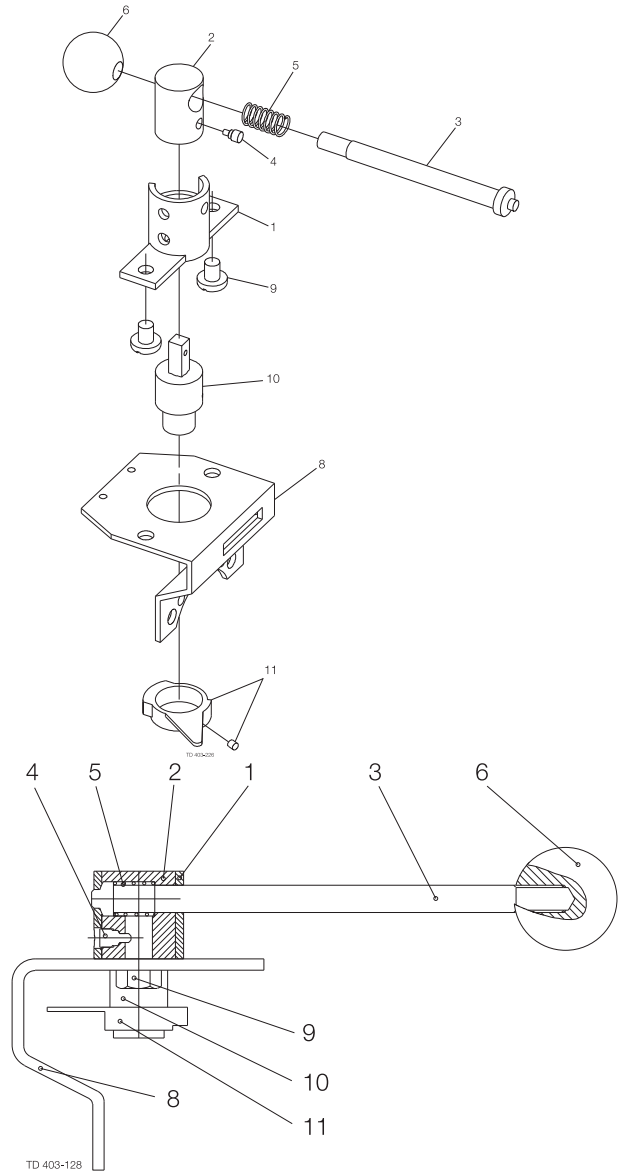

Regulating handle with infinite positions

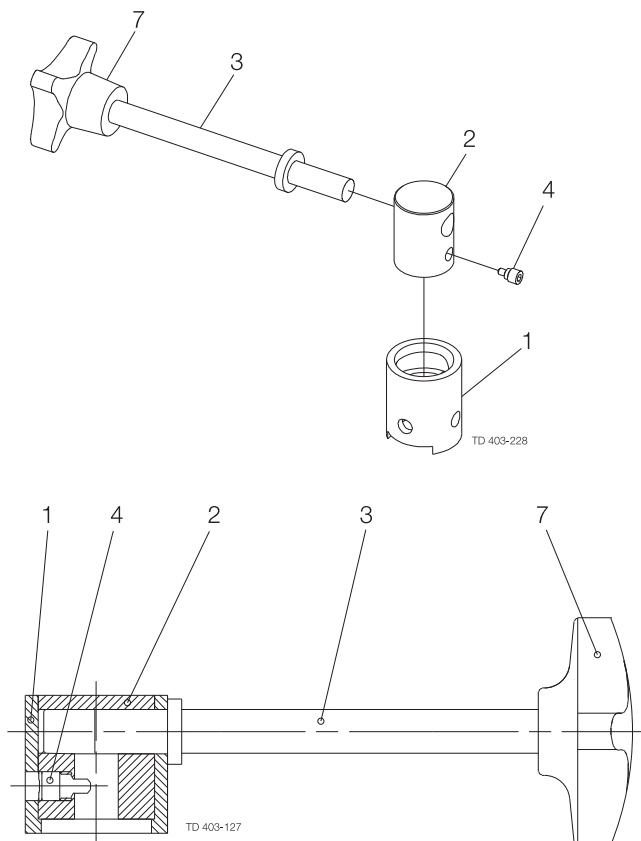

Lockable Multiposition Handle

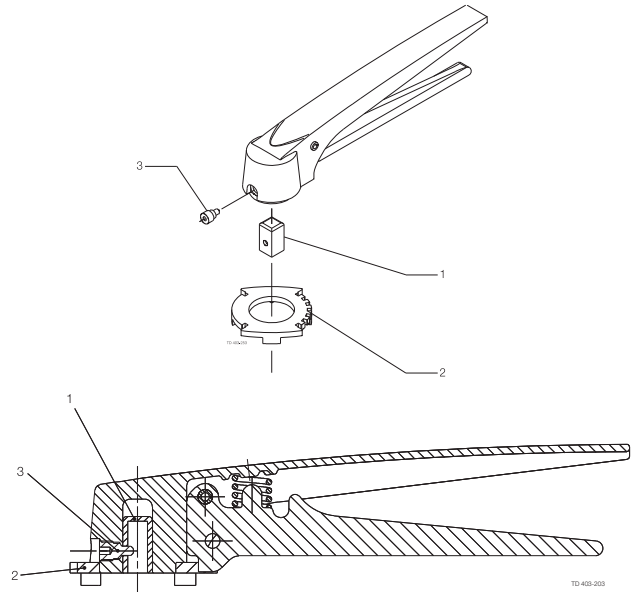

The drawings and the parts list include all items.

Parts list Handles

Standard handle, handle for indication unit and regulating handle with infinite positions:

Item	Qty.	Denomination
1	1	Location cap
1a	1	Location cap with 2 pos.
1b	1	Location cap with 4 pos.
2	1	Transfer block
3	1	Handle
4	1	Screw with pin
5	1	Spring
6	1	Ball
7	1	Crosshead
8	1	Bracket
9	1	Screw
10	1	Coupling
11	1	Activating ring with screw

Parts list Handles

Lockable Multiposition Handle:

Item	Qty.	Denomination
1	1	Insert
2	1	Location cap (76-101.6 mm/DN65-100)
		Location cap (25-63.5 mm/DN25-50)
3	1	Screw

How to contact Alfa Laval

Contact details for all countries are continually updated on our website. Please visit www.alfalaval.com to access the information directly.