



Instruction Manual

Toftejorg™ TZ-74

- Covering**
- **Standard Machines**
 - **Machines delivered with ATEX Certification in accordance with Directive 94/9/EC**

IM-TE91A150-EN5
ESE01797EN
Date of issue: December 31, 2011

Contents

Contents	1
Introduction	3
Intended Use	4
Patents and trademarks	4
ATEX Marking	5
General Description	7
Functioning	7
Standard Configurations for Toftejorg TZ-74	8
Standard Configurations for Toftejorg TZ-74 with Self-cleaning Nozzle	8
Standard Configurations for Toftejorg TZ-74 with w. Hub-deflector 180° Down	9
Standard Configurations for Toftejorg TZ-74 with w. Hub-deflector 180° Up	9
Available add-ons	9
Technical Data for Toftejorg TZ-74	10
Principal dimensions in mm	10
Flow rate	11
Throw length	12
Cleaning time, f. complete pattern (= 8 cycles)	13
Technical Data for Toftejorg TZ-74 Self-cleaning	14
Principal dimensions in mm	14
Flow rate	15
Throw length	16
Cleaning Time, f. complete Pattern (= 8 cycles)	17
Installation and Normal Operation	18
General Safety and Installation Instructions	18
Normal operation	19
Special Conditions for Safe Use in accordance with the ATEX Certification, Directive 94/9/EC	21
Maintenance and repair	23
Service and Repair of ATEX Approved Machines	23
Maintenance and Repair	24
Preventive Maintenance	24
Top Assembly	26
Bottom Assembly	28
Hub Subassembly	30
Stem Subassembly	32
Gear Subassembly	34
Replacement of Collar Bushes	36
Replacement of Ball Races	38
Replacement of Main Collars	40
Tools	42
Standard Tool kit for Toftejorg TZ-74	42
Sketch of tools for replacement of Main collars	43
Trouble Shooting Guide	44
Reference List of Parts for Toftejorg TZ-74	46
Cross Sectional Drawing for Toftejorg TZ-74	47

Reference List of Parts for Toftejorg TZ-74 Self-cleaning.....	48
Cross Sectional Drawing for Toftejorg TZ-74 Self-cleaning.....	49
Reference List of Parts for Toftejorg TZ-74 w. Hub deflector.....	50
Cross Sectional Drawing for Toftejorg TZ-74 w. Hub deflector.....	51
Service Kits.....	52
Service Kit for Toftejorg TZ-74 & TZ-74 Self-cleaning, article no. TE21D299.....	52
Major Service Kit for Toftejorg TZ-74 & TZ-74 Self-cleaning, article no. TE21D286.....	52
Standard Tool kit for Toftejorg TZ-74, article no. TE81B055.....	52
How to order Spare Parts and Claim Procedure.....	53
How to contact Alfa Laval Tank Equipment A/S.....	53
Service Card.....	54
Claim Report Working Conditions.....	55
EC Declaration of conformity.....	57

Introduction

This manual has been prepared as a guide for the persons who will be operating and maintaining your tank cleaning machine. The key to long life for your tank cleaning machine will always be a system of carefully planned maintenance; you will appreciate that a tank cleaning machine which has a rough and dirty job to do will need more frequent attention than one working in ideal conditions.

Note: Get the best and most economical performance from your tank cleaning machine. Insufficient preventive maintenance means poor performance, unscheduled stops, shorter lifetime and extra costs. Good preventive maintenance on the contrary means good performance, no unscheduled stops and superior total economy.

You will find the information contained in this manual simple to follow, but should you require further assistance, our Customer Service Department and world-wide net of Distributors will be pleased to help you. Please quote the type and serial number with all your enquiries; this will help us to help you. The type and serial number are placed on the gear house of the tank cleaning machine.

Note: The illustrations and specifications contained in this manual were effective at the date of printing. However, as continuous improvements are our policy, we reserve the right to alter or modify any unit specification on any product without prior notice or any obligation.

© 2011 Alfa Laval Corporate AB

This document and its contents is owned by Alfa Laval Corporate AB and protected by laws governing intellectual property and thereto related rights. It is the responsibility of the user of this document to comply with all applicable intellectual property laws. Without limiting any rights related to this document, no part of this document may be copied, reproduced or transmitted in any form or by any means (electronic, mechanical, photocopying, recording, or otherwise), or for any purpose, without the expressed permission of Alfa Laval Corporate AB. Alfa Laval Corporate AB will enforce its rights related to this document to the fullest extent of the law, including the seeking of criminal prosecution.

Intended Use

It is to be verified by the end-user:

- that the tank cleaning machine is in conformity with respect to tank, vessel or container size in which it will be used.
- that the construction materials (both metallic and non-metallic) are compatibility with product, flushing media, cleaning media, temperatures and pressure under the intended use.

Patents and trademarks

This Instruction Manual is published by Alfa Laval Tank Equipment A/S without any warranty. Improvements and changes to this Instruction Manual may at any time be made by Alfa Laval Tank Equipment A/S without prior notice. Such changes will, however, be incorporated in new editions of this Instruction Manual.

© Alfa Laval Tank Equipment A/S, 2011. All rights reserved.

The Alfa Laval logotype is a trademark or a registered trademark of Alfa Laval Corporate AB. "Toftejorg" is a trademark or registered trademark of Alfa Laval Tank Equipment A/S. Other products or company names mentioned herein may be the trademarks of their respective owners. Any rights not expressly granted herein are reserved

If ordered with ATEX certificate: ATEX Marking

The Toftejorg TZ-74 is certified as category I components. The certification is carried out by the notified body Baseefa, who has issued the certificate no. 10ATEX0188X. The marking on the ATEX certified Toftejorg TZ-74 is as follows:

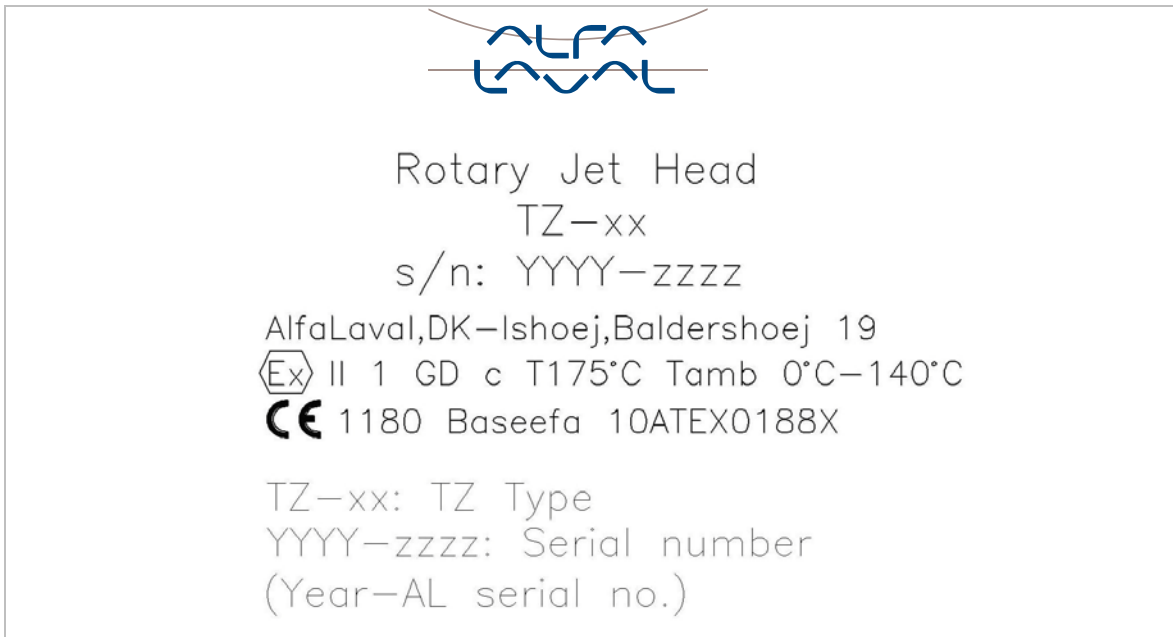

Changes to the machine are not allowed without approval by the person responsible for the ATEX certification at Alfa Laval Tank Equipment A/S. If changes are made – or spare parts other than Alfa Laval original spare parts are used - the EC Type Examination certification (the ATEX Directive) is no longer valid.

**Important
ATEX
information:**



Also see page 23 regarding special conditions for repair of ATEX certified machines.

- Blank page -

General Description

The Toftejorg TZ-74 is a media driven and media lubricated tank cleaning machine. As it is self-lubricating, there are no lubricating substances such as oil grease etc. in the machine which need to be regularly changed.

The Toftejorg TZ-74 is available in a version with a self-cleaning nozzle on the body for better cleaning of the down pipe and the body.

Functioning

The flow of the cleaning fluid passes through a guide and a turbine, which accordingly is set into rotation. The turbine rotation is through a gearbox transformed into a combined horizontal rotation of the machine body and a vertical rotation of the nozzles.

The combined motion of the machine body and the nozzles ensures a fully indexed tank cleaning coverage. After $5 \frac{5}{8}$ revolutions of the Hub with nozzles ($5 \frac{3}{8}$ revolutions of the machine body) one coarse cleaning pattern is laid out on the tank surface. During the following rounds, this pattern is repeated 7 times, each of which is displaced $\frac{1}{8}$ of the mesh in the pattern. After a total of 45 revolutions of Hub with nozzles (43 revolutions of the machine body), a complete cleaning pattern has been laid out, and the first pattern is repeated.

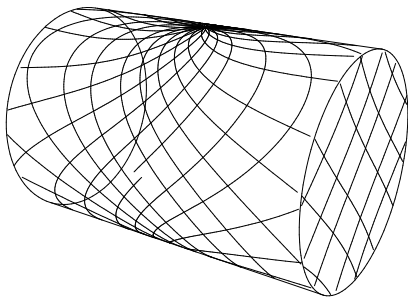

First cycle

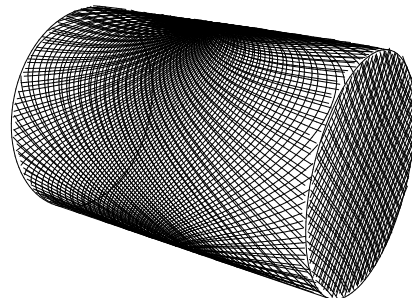

Full pattern

The speed of rotation of the turbine depends on the flow rate through the machine. The higher the flow rate the higher the speed of rotation will be. In order to control the RPM of the machine for a wide range of flow rates, the efficiency of the turbine can be changed (100% and 0% Turbine/Inlet guide).

Apart from the jet flow through the nozzles, fluid is leaking through the top of the machine, at the hub and through the bottom cover. The leakage between the moving parts at the top and at the hub are cleaning the gabs and thus preventing build-up of material that might cause the friction. The flow through the bottom cover is due to the fact that the machine is media lubricated and that accordingly a flow through the gearbox is needed.

General Description (continued)

The machine is equipped with a clutch in the hub, which gives the possibility of rotation by hand the nozzles, when the machine is to be lifted out through a tank opening.

Standard Configurations for Toftejorg TZ-74

Connection	Turbine/ Inlet Guide	Nozzles (mm) (½" thread conn.)	Article No.	
			Standard machines	ATEX certified machines
<u>Top Cone:</u> 1½"NPT, Female	100%	4 x ø6	TE21D108	TE21D108-70
		4 x ø7	TE21D110	TE21D110-70
		4 x ø8	TE21D112	TE21D112-70
	0%	4 x ø7	TE21D128	TE21D128-70
		4 x ø8	TE21D130	TE21D130-70
		2 x ø10	TE21D132	TE21D132-70
<u>Top Cone:</u> 1½" BSP, Female	100%	4 x ø6	TE21D208	TE21D208-70
		4 x ø7	TE21D210	TE21D210-70
		4 x ø8	TE21D212	TE21D212-70
	0%	4 x ø7	TE21D228	TE21D228-70
		4 x ø8	TE21D230	TE21D230-70
		2 x ø10	TE21D232	TE21D232-70
<u>Top Cone:</u> 2" NPT, Female	100%	4 x ø6	TE21D108-05	TE21D108-75
		4 x ø7	TE21D110-05	TE21D110-75
		4 x ø8	TE21D112-05	TE21D112-75
	0%	4 x ø7	TE21D128-05	TE21D128-75
		4 x ø8	TE21D130-05	TE21D130-75
		2 x ø10	TE21D132-05	TE21D132-75

Standard Configurations for Toftejorg TZ-74 with Self-cleaning Nozzle

Connection	Turbine/ Inlet Guide	Nozzles (mm) (½" thread conn.)	Article No.	
			Standard machines	ATEX certified machines
<u>Top Cone:</u> 1½"NPT, Female	100%	4 x ø6	TE21D008	TE21D008-70
		4 x ø7	TE21D010	TE21D010-70
		4 x ø7	TE21D028	TE21D028-70
	0%	4 x ø8	TE21D030	TE21D030-70
		2 x ø10	TE21D032	TE21D032-70
<u>Top Cone:</u> 1½" BSP, Female	100%	4 x ø6	TE21D058	TE21D058-70
		4 x ø7	TE21D060	TE21D060-70
		4 x ø7	TE21D078	TE21D078-70
	0%	4 x ø8	TE21D080	TE21D080-70
		2 x ø10	TE21D082	TE21D082-70
<u>Top Cone:</u> 2" BSP, Female	100%	4 x ø6	TE21D008-05	TE21D008-75
		4 x ø7	TE21D010-05	TE21D010-75
		4 x ø7	TE21D028-05	TE21D028-75
	0%	4 x ø8	TE21D030-05	TE21D030-75
		2 x ø10	TE21D032-05	TE21D032-75

General Description (continued)

Standard Configurations for Toftejorg TZ-74 with w. Hub-deflector 180° Down

Connection	Turbine/ Inlet Guide	Nozzles (mm) (½" thread conn.)	Article No.	
			Standard machines	ATEX certified machines
<u>Top Cone:</u>	100%	4 x ø7	TE21D110-03	TE21D110-73
		4 x ø8	TE21D112-03	TE21D112-73
1½"NPT, Female	0%	4 x ø8	TE21D130-03	TE21D130-73
<u>Top Cone:</u>	100%	4 x ø7	TE21D210-03	TE21D210-73
		4 x ø8	TE21D212-03	TE21D212-73
1½"BSP, Female	0%	4 x ø8	TE21D230-03	TE21D230-73

Standard Configurations for Toftejorg TZ-74 with w. Hub-deflector 180° Up

Connection	Turbine/ Inlet Guide	Nozzles (mm) (½" thread conn.)	Article No.	
			Standard machines	ATEX certified machines
<u>Top Cone:</u>	100%	4 x ø7	TE21D110-04	TE21D110-74
		4 x ø8	TE21D112-04	TE21D112-74
1½"NPT, Female	0%	4 x ø8	TE21D130-04	TE21D130-74
<u>Top Cone:</u>	100%	4 x ø7	TE21D210-04	TE21D210-74
		4 x ø8	TE21D212-04	TE21D212-74
1½"BSP, Female	0%	4 x ø8	TE21D230-04	TE21D230-74

Available add-ons

- ATEX, category 1 for installation in zone 0/20
TE21DXXX-XX ATEX

Explanation to Add-ons

ATEX, category 1 for installation in zone 0/20 in accordance with Directive 94/9/EC

Technical Data for Toftejorg TZ-74

Weight of machine	:	6,1 kgs (13,6 lb)
Working pressure	:	3-12 bar (45-175 psi)
Recommended inlet pressure	:	3-8 bar (45-120 psi)
Working temperature max.	:	95° C (200 F)
Ambient temperature	:	0 – 140°C (95°C - 140°C when not operated)
Materials	:	Stainless steel AISI 316/316L, A4, PTFE, Tefzel 200, PEEK, Teflon TFM

Principal dimensions in mm

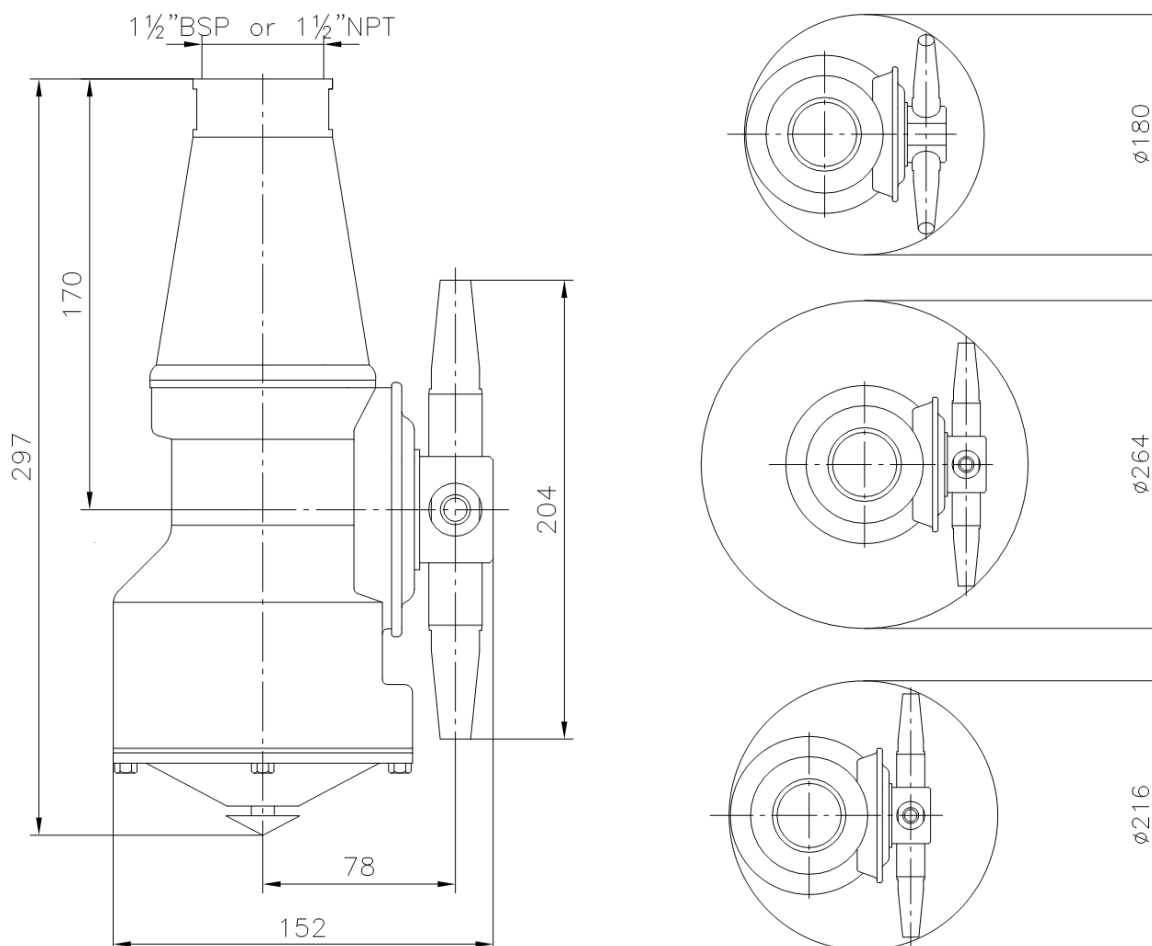

Technical Data for Toftejorg TZ-74 (continued)

Flow rate

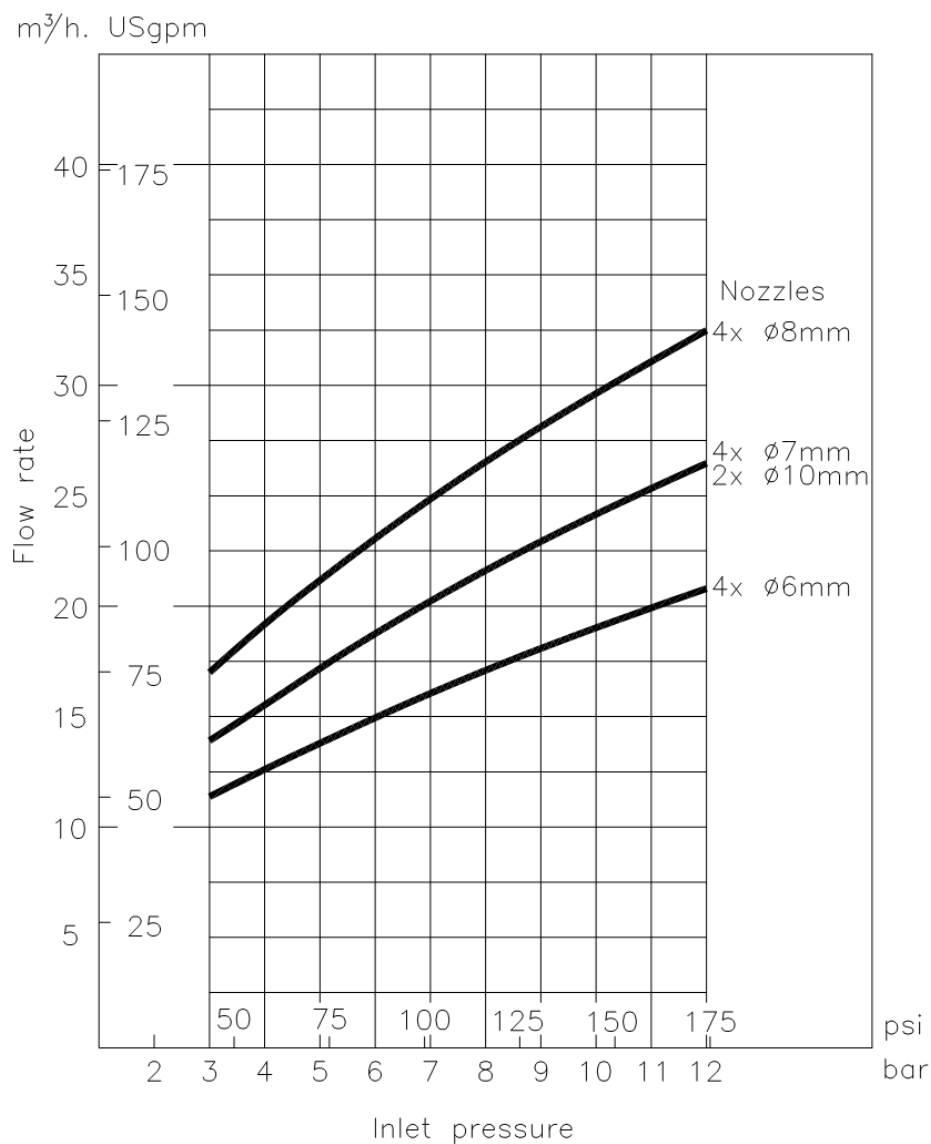

Technical Data for Toftejorg TZ-74 (continued)

Throw length

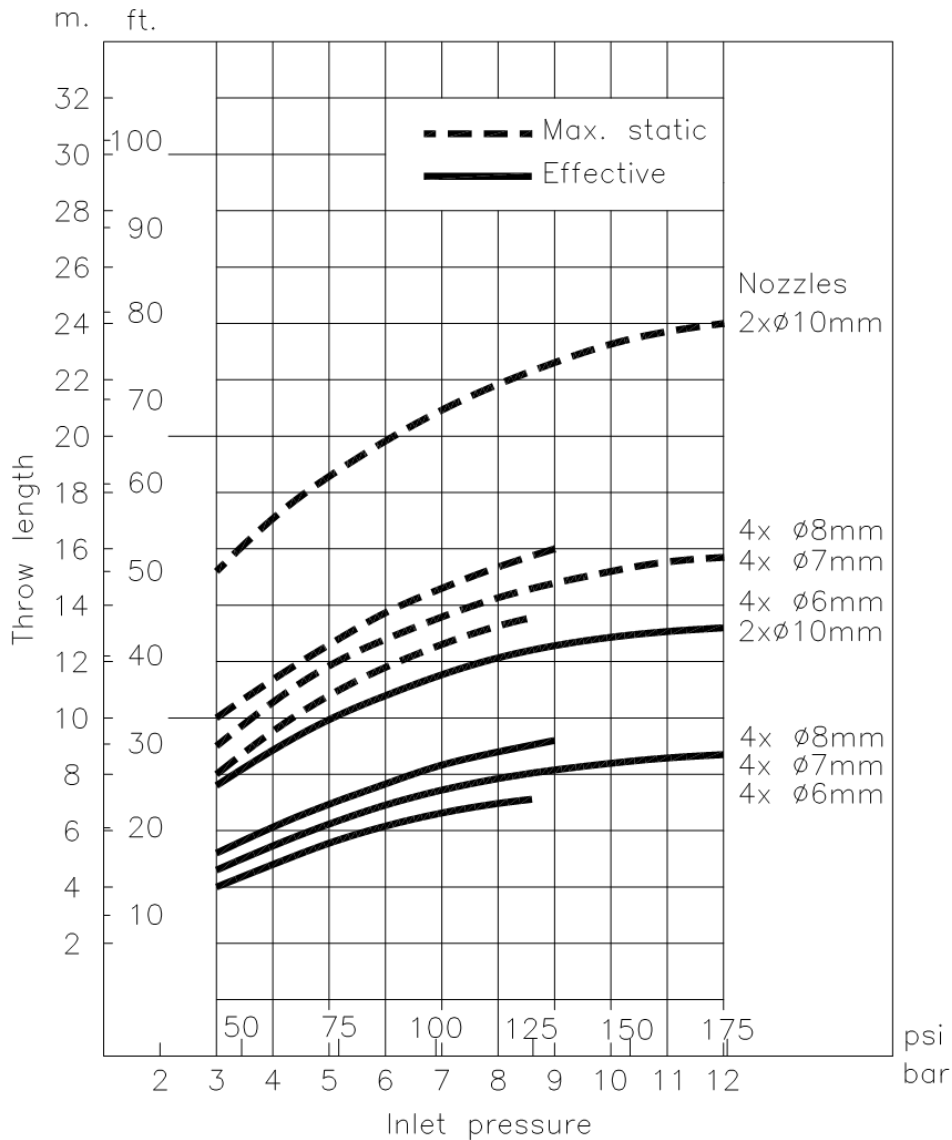

Note: Throw lengths are measured as max. horizontal throw length at static condition. Vertical throw length upwards is approx. 1/3 less.

Effective throw length is defined as impact centre of jet 250 mm water column (50 lbs/sq.ft) Effective throw length varies depending on jet transverse speed over surface, substance to be removed, cleaning procedure and agent.

The inlet pressure has been taken immediately before the machine inlet. In order to achieve the performance indicated in the curves, the pressure drop in the supply lines between pump and machine must be taken into consideration.

Technical Data for Toftejorg TZ-74 (continued)

Cleaning time, f. complete pattern (= 8 cycles)

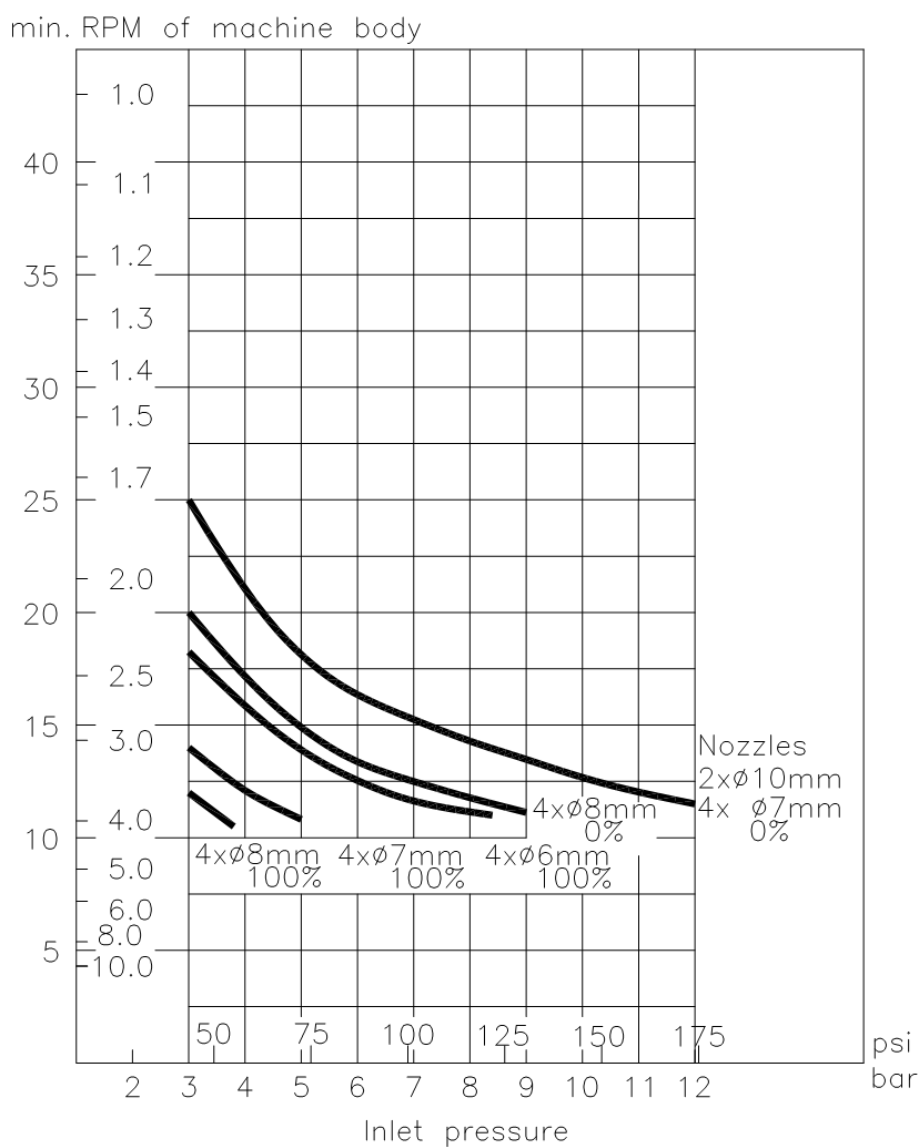

Technical Data for Toftejorg TZ-74 Self-cleaning

Weight of machine	:	6,1 kgs (13,6 lb)
Working pressure	:	3-12 bar (45-175 psi)
Recommended inlet pressure	:	3-8 bar (45-120 psi)
Working temperature max.	:	95° C (200 F)
Ambient temperature	:	0 – 140°C (95°C - 140°C when not operated)
Materials	:	Stainless steel AISI 316/316L, A4, PTFE, Tefzel 200, PEEK, Teflon TFM

Principal dimensions in mm

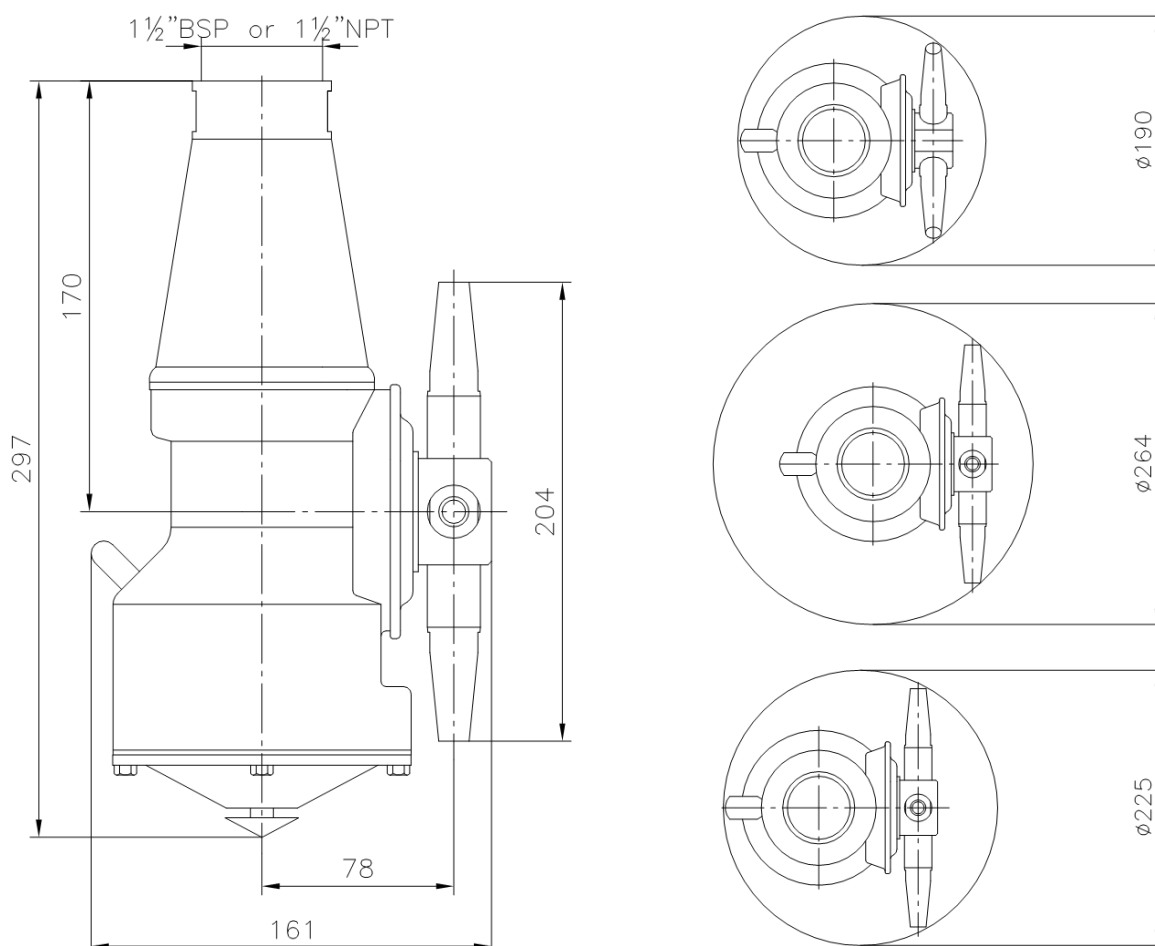

Technical Data for Toftejorg TZ-74 Self-cleaning (continued)

Flow rate

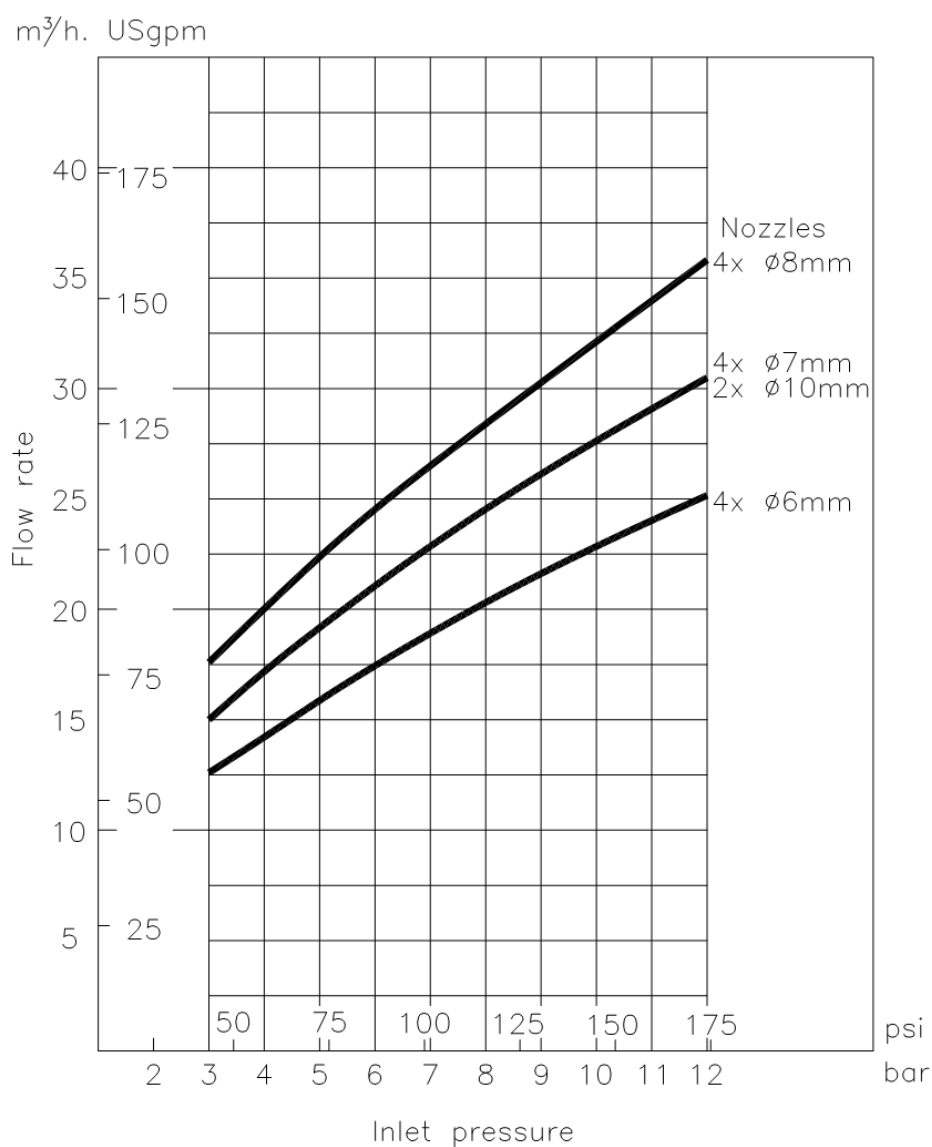

Technical Data for Toftejorg TZ-74 Self-cleaning (continued)

Throw length

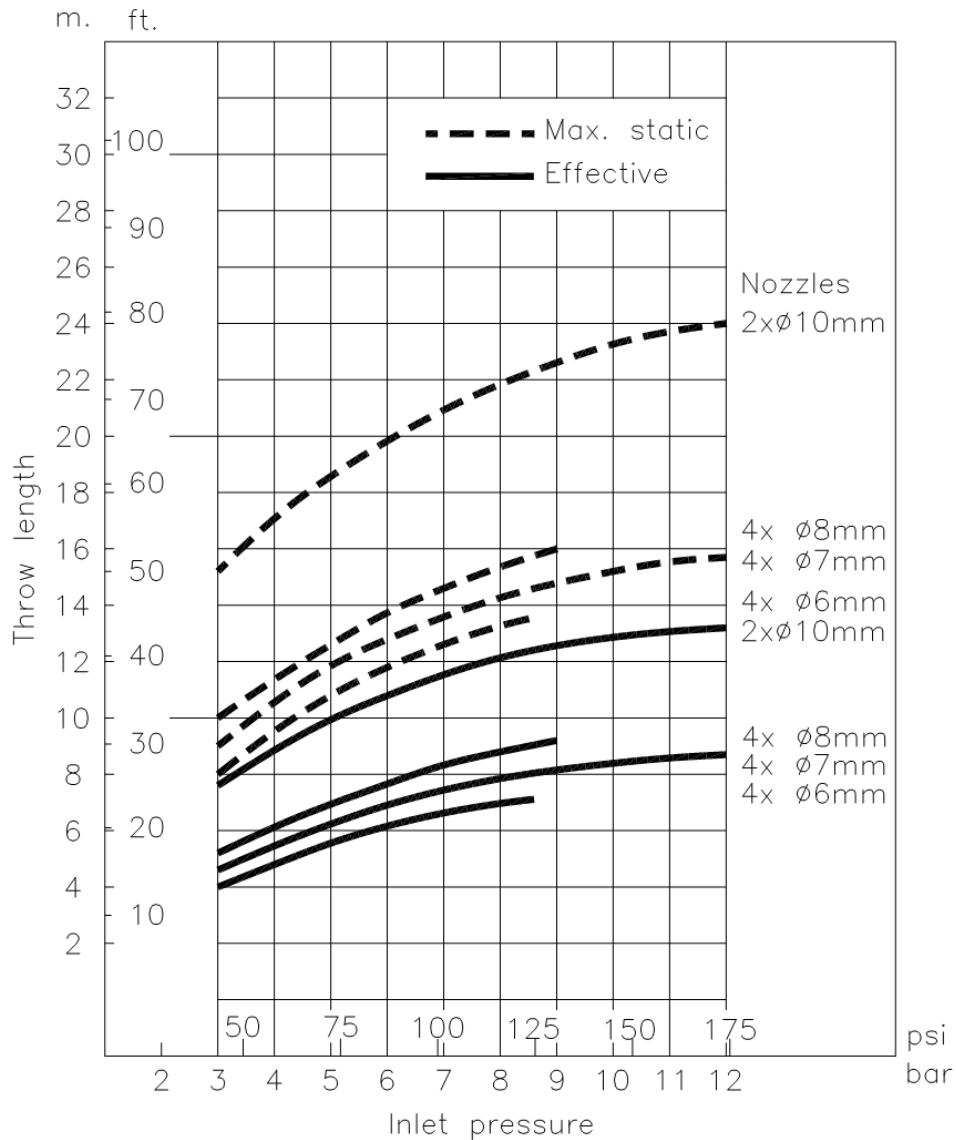

Note: Throw lengths are measured as max. horizontal throw length at static condition. Vertical throw length upwards is approx. 1/3 less.

Effective throw length is defined as impact centre of jet 250 mm water column (50 lbs/sq.ft) Effective throw length varies depending on jet transverse speed over surface, substance to be removed, cleaning procedure and agent.

The inlet pressure has been taken immediately before the machine inlet. In order to achieve the performance indicated in the curves, the pressure drop in the supply lines between pump and machine must be taken into consideration.

Technical Data for Toftejorg TZ-74 Self-cleaning (continued)

Cleaning Time, f. complete Pattern (= 8 cycles)

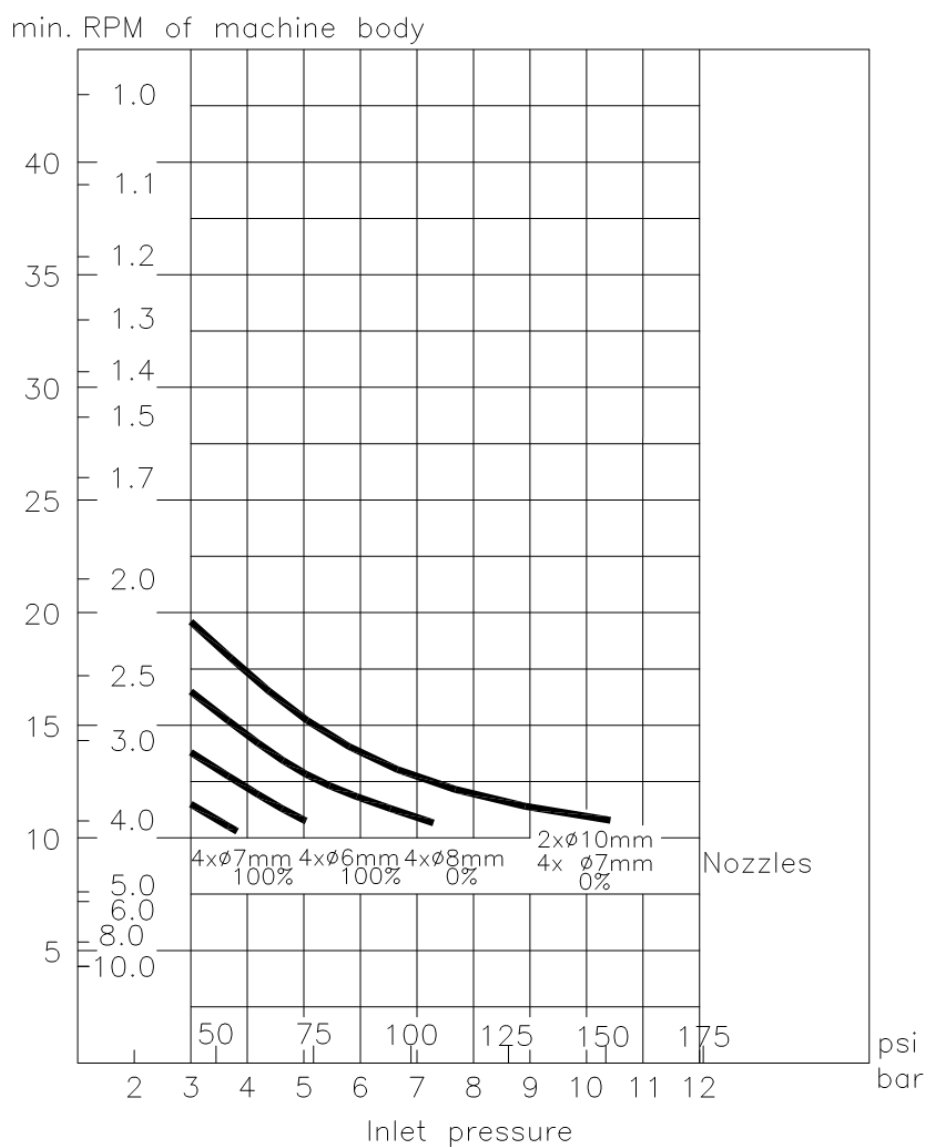

Installation and Normal Operation

General Safety and Installation Instructions

The tank cleaning machine should be installed in a vertical position (upright or upside down). It is recommended to install a filter in the supply line in order to avoid large particles to clog inside the machine. Before connecting the machine into the system, all supply lines and valves should be flushed to remove foreign matter.

For devices with tapered thread connections to the down pipe, it is recommended that you secure the connection in a manner appropriate for the application. Subject to the intended use environment and any inhouse user requirements or policies, a liquid threadlocking adhesive such as Loctite No. 243 or equivalent could be used. Other methods could be acceptable and subject to customer preference.

Note: The machine shall be installed in accordance with national regulations for safety and other relevant regulations and standards.

Precautions shall be made to prevent starting of the cleaning operation, while personnel are inside the tank or otherwise can be hit by jets from the nozzles.

In EU-countries the complete system must fulfil the EU-Machine Directive and depending of application, the EU-Pressure Equipment Directive, the EU-ATEX Directive and other relevant Directives and shall be CE-marked before it is set into operation.

**ATEX
Warning:**



If the machine is used in potential explosive atmospheres, tapes or joint sealing compounds which are electrical insulators must not be used on threads or joints, unless an electrical connection is otherwise established to ensure an effective earthing. In addition, connecting pipe work, must be electrically conductive and earthed to the tank structure. The resistance between the nozzles and the tank structure should not exceed 20,000 Ohm. This is essential to avoid the build-up of static electricity on the machine.

For further information see DS/CLC/TR 50404:2003 Safety of Machinery, guidance and recommendations for the avoidance of hazards due to static electricity.

The machine as delivered has been tested at the factory before shipping. For transportation reasons, the nozzles have been screwed off after the test. In order to secure the nozzles against falling off due to vibrations and other external strains it is important that the nozzles are tightened properly after mounting. If not, the nozzles may be blown off during tank cleaning and cause severe damage on tank, valves and pump. This is especially important if machines are fixed installed in tanks and vessels within the transportation sector in trucks, railcars and onboard ships.

Normally, it is sufficient to tighten the nozzles with the specified torque. However, depending on the application and local policies an extra securing may be preferred.

Subject to the intended use, environment and any inhouse user requirements or policies, a liquid threadlocker such as Loctite No. 243 or equivalent could be used. Other methods could be acceptable and subject to customer preference. For detailed instruction on pre-cleaning and application of the product carefully follow the instruction on the used locking system.

Installation and Normal Operation (continued)

1. Clamp machine firmly in a vice. Protect machine with rubber pad under the machine and use rubber jaws on the vice. Mount jaws upside down to ensure firm grip on the machine. Set torque wrench at the specified tightening torque.
2. Hold one nozzle with flat spanner to counteract while tightening the opposite nozzle with the torque wrench.

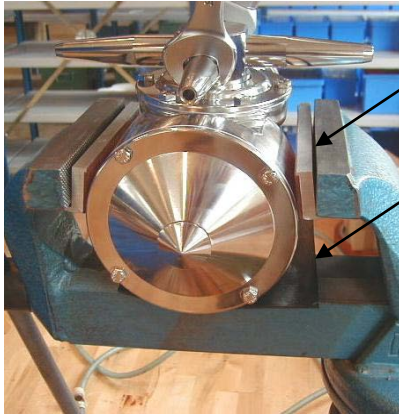

Rubber jaw mounted upside down

Protect with rubber pad



Recommended tightening torque: 40 Nm

3. Check that the machine is in operating condition by inserting 3/16" hex Screwdriver (tool No. TE134A) in screw in top of Turbine shaft and easily turn Turbine shaft clockwise. If any resistance is recognised, the machine should be disassembled to localise the cause.

Normal operation

Cleaning Media

Use only cleaning media compatible with stainless steel AISI 316/316L, A4, PTFE, Tefzel 200, PEEK, Teflon TFM. Please note that PEEK is not resistant to concentrated sulfuric acid. Normal detergents, moderate solutions of acids and alkalis will be acceptable. Aggressive chemicals, excessive concentrations of chemicals at elevated temperatures as well as hydrochlorides should be avoided. If you are in doubt, contact your distributor.

After Use Cleaning

After use flush the machine with fresh water. Cleaning solutions should never be allowed to dry or set-up in the system due to possible "salting out" or "scaling" of the cleaning ingredient. If cleaning media contains volatile chloride solvents, it is recommended not to flush with water after use, in case this can create hydrochloric acid.

Installation and Normal Operation (continued)

Normal Operation (continued)

Pressure

Avoid hydraulic shocks. Put on pressure gradually. Do not exceed 12 bar inlet pressure. Recommended inlet pressure appears from Technical Data (page 10-14). High pressure in combination with high flow rate will increase consumption of wear parts.

ATEX Warning: If stream cleaning is done through the machine, the steam pressure must not cause the machine to rotate.



ATEX Warning: If the machine is drained using compressed air, then the compressed air pressure must not cause the machine to rotate.



Temperature

In accordance with the ATEX specifications regarding special conditions for safe use, see page 21.

ATEX Warning: Tanks with capacities greater than 100 m³ that could contain a flammable atmosphere should not be steam cleaned, as steam issuing from a nozzle could contain charged droplets.



Tanks smaller than this may be steam cleaned providing that: the steam nozzles and other metal parts of the system are reliably earthed and grounded to the tank structure.

ATEX Warning: In potentially explosive atmospheres, the temperature must not exceed the maximum surface temperature according to the temperature class for the combustible gas or liquid.



Installation and Normal Operation (continued)

Special Conditions for Safe Use in accordance with the ATEX Certification, Directive 94/9/EC

ATEX Warning: The unit may be operated, in a hazardous area, only when filled with the process fluid.



ATEX Warning: The maximum permitted process fluid temperature and ambient temperature, when the machine is operating is 95°C.



When the machine is **not** operating, the maximum permitted ambient temperature is 140°C.

ATEX Warning: The maximum permitted process fluid pressure is 12 bar.



In addition to the above mentioned precautions relating to the ATEX guidelines Directive 94/9/EC of March 23 1994, the Safety Precautions on page 18 must be observed.

Installation and Normal Operation (continued)

Special Conditions for Safe Use in accordance with the ATEX Certification, Directive 94/9/EC

ATEX Warning: The unit must not be operated in a vessel having an enclosed volume of greater than 100m³.

Tanks larger than 100 m³

To use Tank Cleaning Machines in tanks larger than 100m³ is possible under certain conditions.

It is necessary to know the current factors such as tank size, cleaning solvent and product.

Additives can be used in the cleaning solvent, or, for example, the tank can be filled with nitrogen. The basic rules are described in the guide "CLC / TR 50404:2003".

Following a guidance document such as "CLC / TR 50404:2003" to establish safe use of machinery and process is the users own responsibility and is not covered by the ATEX certification for this product.

ATEX Warning: The user must address the electrostatic hazards generated from the process of the equipment in accordance with guidance document CLC/TR 50404:2003.





In addition to the above mentioned precautions relating to the ATEX guidelines Directive 94/9/EC of March 23 1994, the Safety Precautions on page 18 must be observed.

Maintenance and repair

Service and Repair of ATEX Approved Machines

In order to ensure compliance with the ATEX regulations for service and repair in accordance with EN 60079-19, all service and repair of ATEX approved machines should be performed by Alfa Laval Tank Equipment A/S, Ishoej, Denmark.

ATEX Warning:	ATEX requirements regarding repair of ATEX approved machines according to EN 60079-19.
	<p>A tag with the following labelling information must be attached to the machine:</p> <ul style="list-style-type: none">- Repair symbol - Alfa Laval logo and address- Repair number- Date of repair- Machine serial number <p>The tag must be laminated and attached to the machine-downpipe outside the tank using a cable tie.</p>

If a customer wishes to carry out service or repair himself, it is the responsibility of the repair shop to ensure that the ATEX requirements are met in any way possible. After performing service or repair, the repair shop thus carries the full responsibility for the ATEX approval of the machine.

Maintenance and Repair

Preventive Maintenance

In order to keep your tank cleaning machine servicing you as an efficient tool in your tank cleaning operations, it is essential to maintain its high performance by following a simple preventive maintenance programme, which will always keep your tank cleaning machine in good condition.

Good maintenance is careful and regular attention!

The following recommended preventive maintenance is based on tank cleaning machines working in average conditions. However, you will appreciate that a tank cleaning machine, which has a rough and dirty job to do, will need more frequent attention than one working in ideal conditions. We trust that you will adjust your maintenance programme to suit.

Always use only proper tools. Use Toftejorg TZ-74 standard tool kit. Never force, hammer or pry components together or apart. Always perform all assembly/disassembly steps in the order described in this manual.

Never assemble components without previous cleaning. This is especially important at all mating surfaces. Work in a clear well lighted work area.

Note: Recommended tightening torque for all screws: 4-5 Nm.

Every 300 working hours

1. Disassemble machine as described on the following pages.
2. Clean material build-up and deposits from internal parts with Scotch-brite, S-Ultrafine, eventually chemical cleaner and fine abrasive cloth.
3. Check Slide bearings (pos. 28 on the cross sectional drawings, page 47 and 49) for wear. If hole is worn oval to max. diameter more than 10.4 mm, Slide bearings should be replaced. If end face of Slide bearing is worn more than x mm into Slide bearing, it should be replaced.

Under Turbine shaft	:	x = 1.5 mm
At Horizontal shaft	:	x = 0.5 mm

4. Check Collar bushes (pos. 10) in Gear frame. If holes are worn oval to max. diameter more than 13.4 mm, Collar bush should be replaced. How to replace Collar bushes, see page 36.

Note: Timely replacement of Slide bearings and Collar bushes will prevent costly damage to the gear box.

Maintenance and Repair (continued)

Preventive Maintenance

5. Check Worm wheels (pos. 11 and pos. 33). If extremely worn, they should be replaced.
6. Check Main bush (pos. 5). If worn it should be replaced.
7. Assemble machines as described in the following pages.
8. Check that the machine is in operating condition by inserting 3/16" hex Screw-driver (tool No. TE134A) in screw in top of Turbine shaft and easily turn Turbine shaft clockwise. If any resistance is recognised, the machine should be disassembled to localise the cause.

Apart from the parts specifically mentioned above, all the remaining wear parts should regularly be inspected for wear. Which parts that are wear parts appear from Reference Lists of Parts, page 46, 48, and 50.

Service Card

For your registration of maintenance carried out, fill in service card which you will find at the back of this manual.

Maintenance and Repair (continued)

Top Assembly

Disassembly

1. Remove 3/16" Screws (pos. 17). Loosen and unscrew with a socket wrench (tool No. TE462A).
2. Lift off Top Cone (pos. 1).
3. Remove Guide /Guide ring (pos. 2). The Guide has a groove in the outer diameter. The Guide is easily lifted out of the Stem by means of two ordinary Screwdrivers inserted into the groove.
4. Remove 3/16" Screw (pos. 15), Spring washer (pos. 16) and Washer (pos. 13). To secure Impeller against rotation, insert carefully Screwdriver (tool No. TE134A), through Impeller (pos. 4) into a hole in the Stem.
5. Pull off Impeller (pos. 4).

Reassembly

1. Reinstall Impeller (pos. 4). Make sure that Impeller is correctly rotated to be pushed onto Turbine shaft. Do not try to hammer Impeller in position, as this will damage Slide bearing under Turbine shaft.
2. Mount Washer (pos. 13), Spring washer (pos. 16) and 3/16" Screw (pos. 15) and tighten. To secure Impeller against rotation insert carefully Screwdriver (tool No. TE134A) through Impeller (pos. 4) into a hole in the Stem.
3. Reinstall Guide /Guide ring (pos. 2).
4. Mount Top Cone (pos. 1). Make sure that it is in correct position over Guide/Guide ring (pos. 2) Rotate Top cone to align holes in Top cone and Stem.
5. Mount and tighten 3/16" Screws (pos. 17) with a socket wrench (tool No. TE462A).

Maintenance and Repair (continued)

Top Assembly

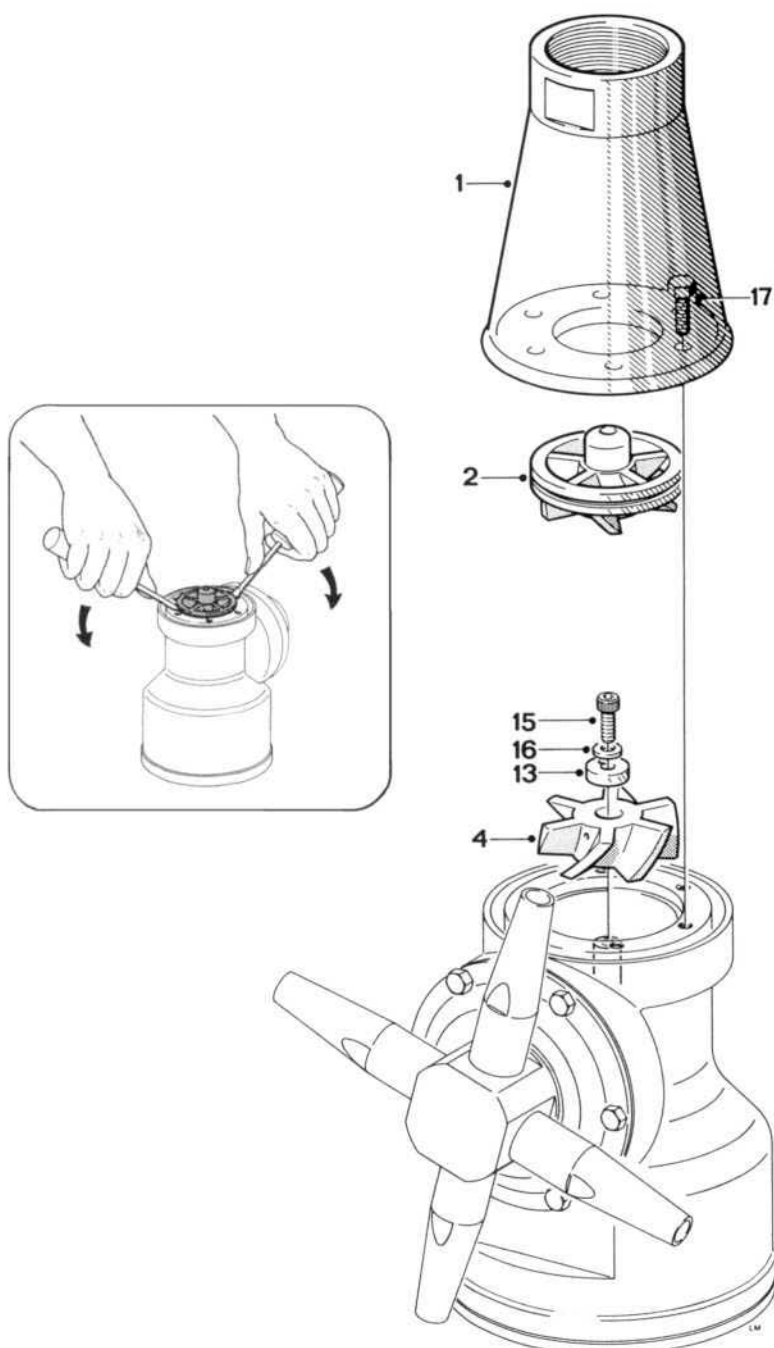

Maintenance and Repair (continued)

Bottom Assembly

Disassembly

1. Turn machine upside down.
2. Remove 3/16" Screws (pos. 31) from Bottom cover (pos. 30).
3. Remove Bottom cover (pos. 30) and Gasket (pos. 32).
4. Remove 3/16" Screws (pos. 15) in Bearing cover (pos. 14). Carefully push out Turbine shaft (pos. 6) from opposite end. Do not try to hammer out Turbine shaft, since this can damage Slide bearing.
5. Remove 3/16" Screws (pos. 15) and Spring Washers (pos. 16) along the circumference of Gear frame (pos. 29). Turn Gear frame about 1 cm ($\frac{1}{2}$ "). Draw out Gear Subassembly (holes in Gear frame are excellent for holding Gear Subassembly).

Reassembly

1. Reinsert Gear subassembly in bottom of machine body. Turn Gear Frame (pos. 29) to align holes in Gear frame and 3/16" threads in body. Mount Spring washers (pos. 16) and 3/16" Screws (pos. 15) along circumference of Gear frame (pos. 29). Tighten screw crosswise.

Note: To secure meshing between Gear wheel (pos. 7) and Pinion (pos. 9). It might be necessary to rotate slightly either the whole Gear Subassembly or the Gear wheel.

2. Reinsert Turbine shaft (pos. 6) with Slide bearing carefully through Gear wheel (pos. 7). Push carefully Slide bearing (pos. 28) into position. Mount Bearing cover (pos. 14) with 3/16" Screws (pos. 15). Tighten crosswise.
3. Place Bottom gasket (pos. 32) and Bottom cover (pos. 30).
4. Mount 3/16" Screws (pos. 31) and tighten crosswise.

Maintenance and Repair (continued)

Bottom Assembly

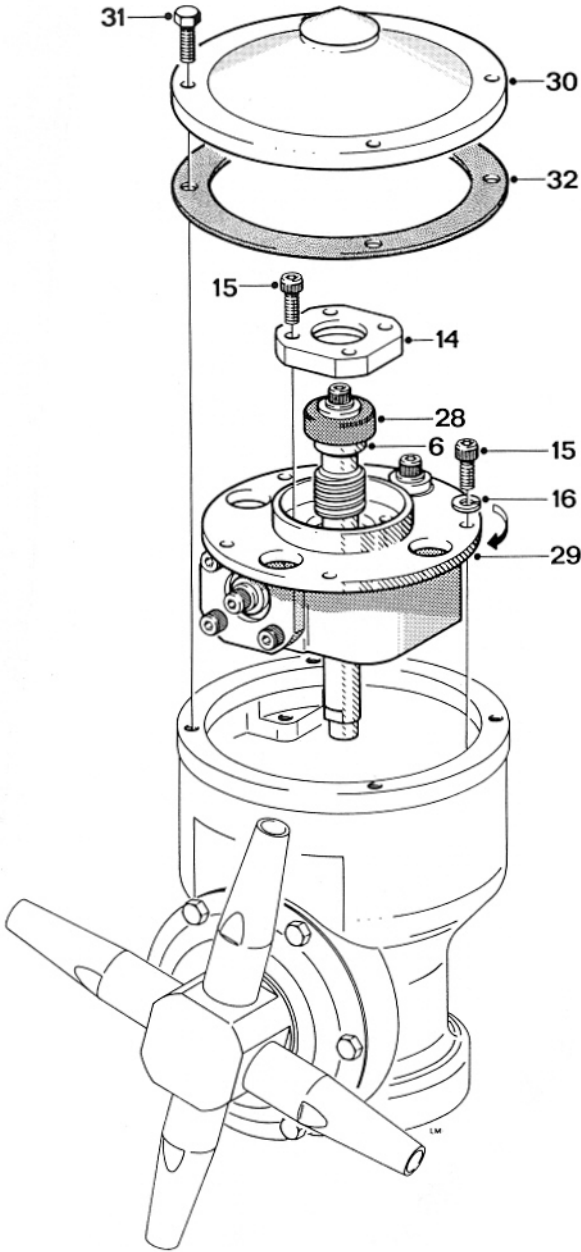

Maintenance and Repair (continued)

Hub Subassembly

Disassembly

1. Remove Nozzles (pos. 20). Nozzles are untightened with a wrench on the faces of the Nozzles.
2. Remove 3/16" Screws (pos. 31), Hub cover (pos. 19), and Gasket (pos. 25).
3. Draw out Hub (pos. 21) together with Ball retainer with balls (pos. 24) and Bevel gear (pos. 18).

If Ball races (pos. 18.1 and 19.1) in Hub cover and in Bevel gear are extremely worn, they should be replaced as well as the Ball retainer with balls (pos. 24). How to replace Ball races see page 38).

Reassembly

1. Slide on Hub (pos. 21). Reinsert Bevel gear with race (pos. 18) and Ball retainer with balls (pos. 24).
2. Mount Gasket (pos. 25) and Hub cover with race (pos. 19), and set with 3/16" Screws (pos. 31). Tighten clockwise.
3. Screw on Nozzles (pos. 20) and tighten with wrench.

Maintenance and Repair (continued)

Hub Subassembly

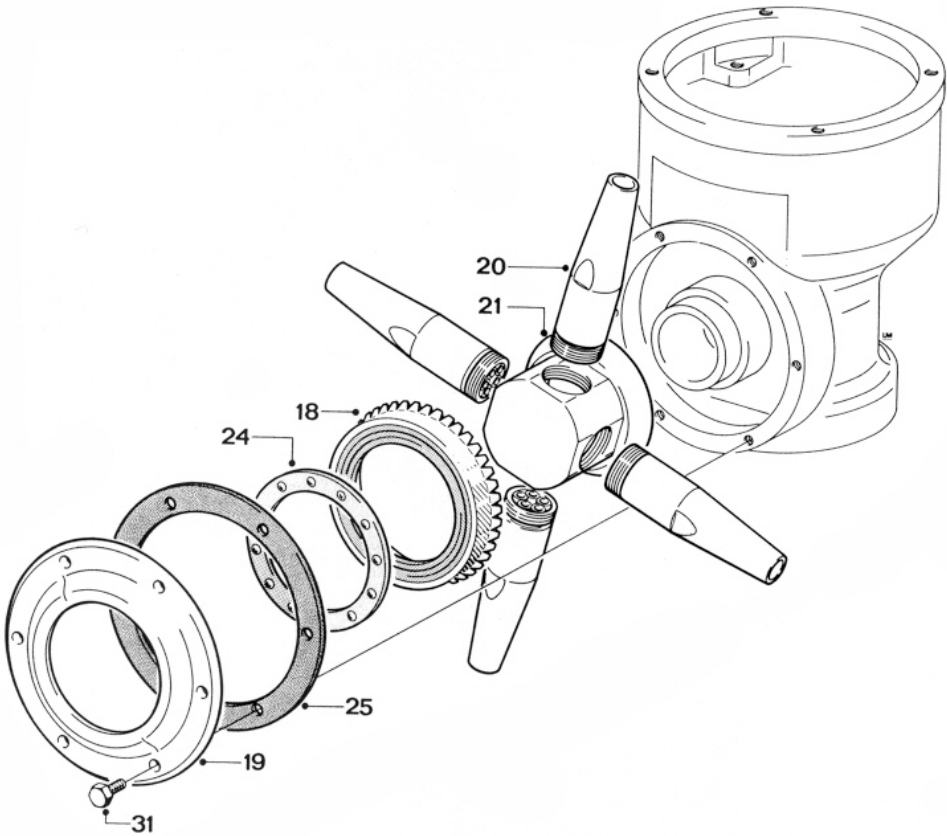

Maintenance and Repair (continued)

Stem Subassembly

Disassembly

1. Place machine in upside-down position.
2. Remove 3/16" Screws (pos. 15) in Gear wheel (pos. 7). To prevent rotation of Stem (pos. 3) mount two 3/16" screws in two holes opposite one another in BIG end of Stem. Place Stem in a vice held by the heads of the two screws.
3. Draw out Gear wheel with ball races (pos. 7) and Ball retainer with balls (pos. 24).
4. Push out Stem (pos. 3).
5. If worn, press out Main bush (pos. 5).

If Ball races in Body (pos. 26.3) and on Gearwheel (pos. 7.1) are extremely worn they should be replaced together with Ball retainer with balls (pos. 24). How to replace Ball races see page 38.

Reassembly

1. If replaced press Main bush (pos. 5) into Stem (pos. 3).
2. Push Stem into Body. Turn machine upside-down.
3. Place Ball retainer with balls (pos. 24) and Gear wheel (pos. 7) into Body on Ball race. Rotate Gearwheel to check free rotation. Mount Gearwheel with 3/16" Screws (pos. 15) and tighten crosswise. To prevent rotation of Stem (pos. 3) mount two 3/16" screws in two holes opposite one another in BIG end of Stem. Place Stem in a vice held by the heads of the two screws.

Maintenance and Repair (continued)

Stem Subassembly

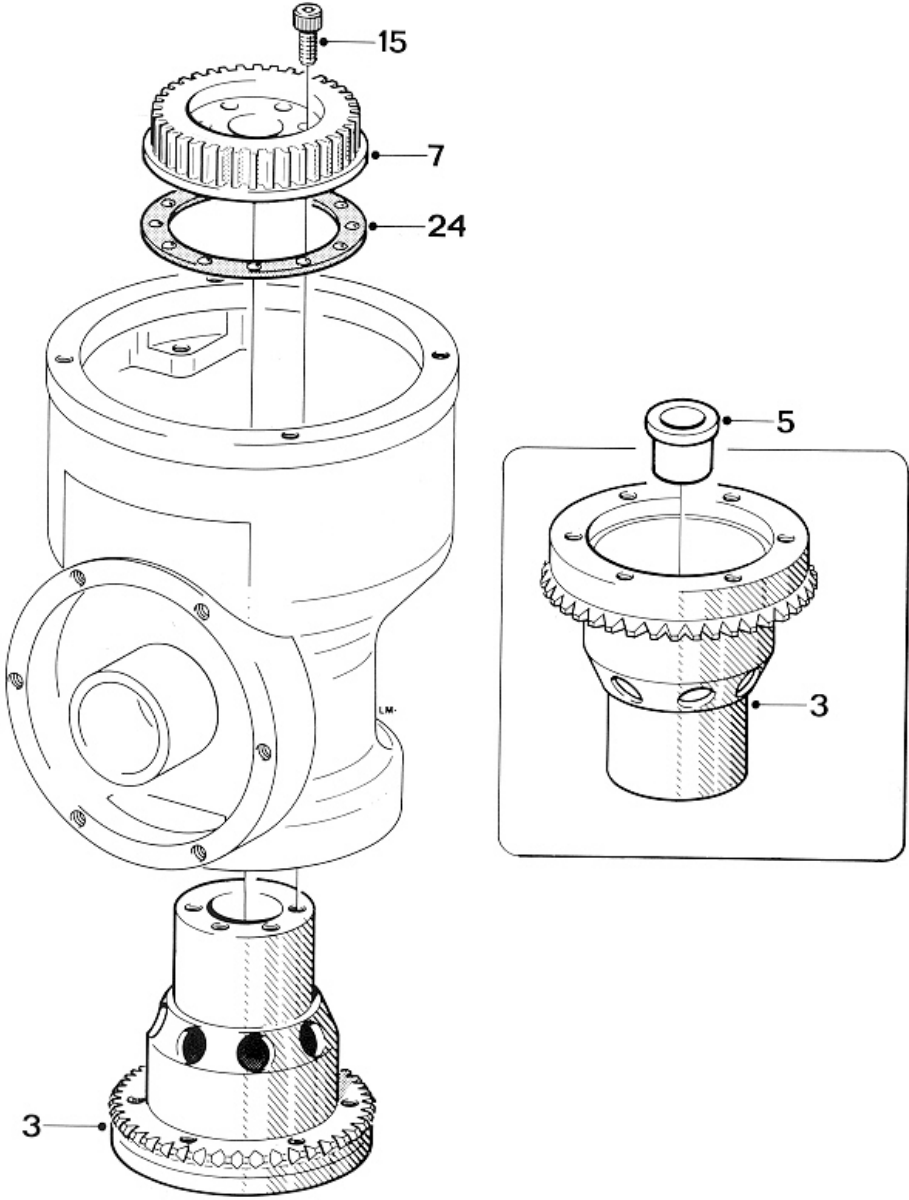

Maintenance and Repair (continued)

Gear Subassembly

Disassembly

1. To make a backstop, remount Turbine shaft (pos. 6) with Slide bearing (pos. 28) into Gear frame (pos. 29). Mount Bearing cover (pos. 14) with 3/16" Screws (pos. 15).
2. Hold Turbine shaft (pos. 6) against 1st stage Worm wheel (pos. 33) with one hand and loosen 3/16" Screws (pos. 15) in Pinion (pos. 9) and Horizontal shaft (pos. 27) with the other hand.
3. Remove 3/16" Screws (pos. 15) in Bearing cover (pos. 14) and take out Turbine shaft (pos. 6).
4. Draw out Horizontal shaft (pos. 27) and 1st stage Worm wheel (pos. 33) after removal of 3/16" Screw (pos. 15), Spring washer (pos. 16) and Washer (pos. 13).
5. Draw out Pinion (pos. 9) and 2nd stage Worm wheel (pos. 11), also freeing Journal (pos. 12) after removal of 3/16" Screw (pos. 15), Spring washer (pos. 16) and Washer (pos. 13).
6. Remove Bearing cover (pos. 14) and Slide bearing (pos. 28) after removal of 3/16" Screw (pos. 15).
7. Remove 3/16" Screw (pos. 15), Spring washer (pos. 16), Washer (pos. 13) and Slide bearing (pos. 28) from Turbine shaft (pos. 6). Use faces on Turbine shaft to hold against rotation.

Warning: Do not damage driver faces on Turbine shaft. Use only proper tools providing a firm grip such as a wrench or a vice.



How to replace Collar bushes (pos. 10), see page 36.

Reassembly

1. Mount Slide bearing (pos. 28) on Turbine shaft (pos. 6) and secure with Washer (pos. 13), Spring washer (pos. 16) and 3/16" Screw (pos. 15). Hold Turbine shaft in a vice or with wrench on driver faces and tighten.
2. Push Slide bearing (pos. 28) for Horizontal shaft (pos. 27) into Gear frame (pos. 29) and fix Bearing cover (pos. 14) with 3/16" Screws (pos. 15). Tighten crosswise.
3. Insert 2nd stage Worm wheel (pos. 11), Pinion (pos. 9) and Journal (pos. 12). Mount Washer (pos. 13), Spring washer (pos. 16) and fix with 3/16" Screw (pos. 15). Check rotation.

Maintenance and Repair (continued)

Gear Subassembly

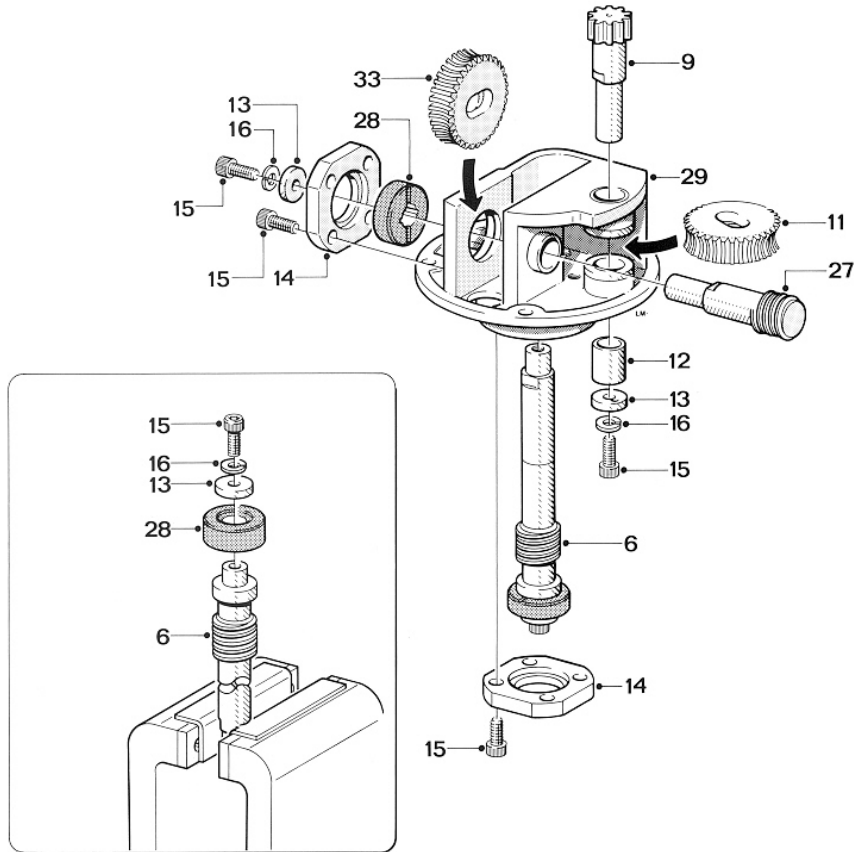

Note: It is important that the Screw holding the Pinion is fastened to a torque moment of 5 Nm, to secure it from loosening.

4. Insert 1st stage Worm wheel (pos. 33) and Horizontal shaft (pos. 27). Mount Washer (pos. 13), Spring washer (pos. 16) and fix with 3/16" Screw (pos. 15). Check rotation.
5. Reinstall Turbine shaft (pos. 6) in Gear frame as mentioned under Disassembly, point 1.
6. Hold Turbine shaft (pos. 6) against 1st stage Worm wheel and tighten 3/16" Screws (pos. 15) in Horizontal shaft (pos. 27) and Pinion (pos. 9).
7. Remove Turbine shaft (pos. 6) with Slide bearing (pos. 28) before Gear subassembly is inserted in machine body.

Maintenance and Repair (continued)

Replacement of Collar Bushes

1. Place Gear frame (pos. 29) upside down with a firm support under the flange. Use for instance jaws of a vice. Do not clamp on machined surfaces. With Pusher (tool No. TE81B033, see page **Error! Bookmark not defined.**) knock out Collar bush.
2. Turn Gear frame to upright position and hold over support such as flat steel bar clamped in a vice. Knock out Collar bush with Pusher.
3. Turn Gear frame 90° and hold over support. Knock out collar bush with Pusher.

Warning: To avoid risk of deforming Gear frame, it is utmost important that it is supported while the Collar bushes are being knocked out.



4. Clean holes and push in new Collar bushes into Gear frame.

Maintenance and Repair (continued)

Replacement of Collar Bushes

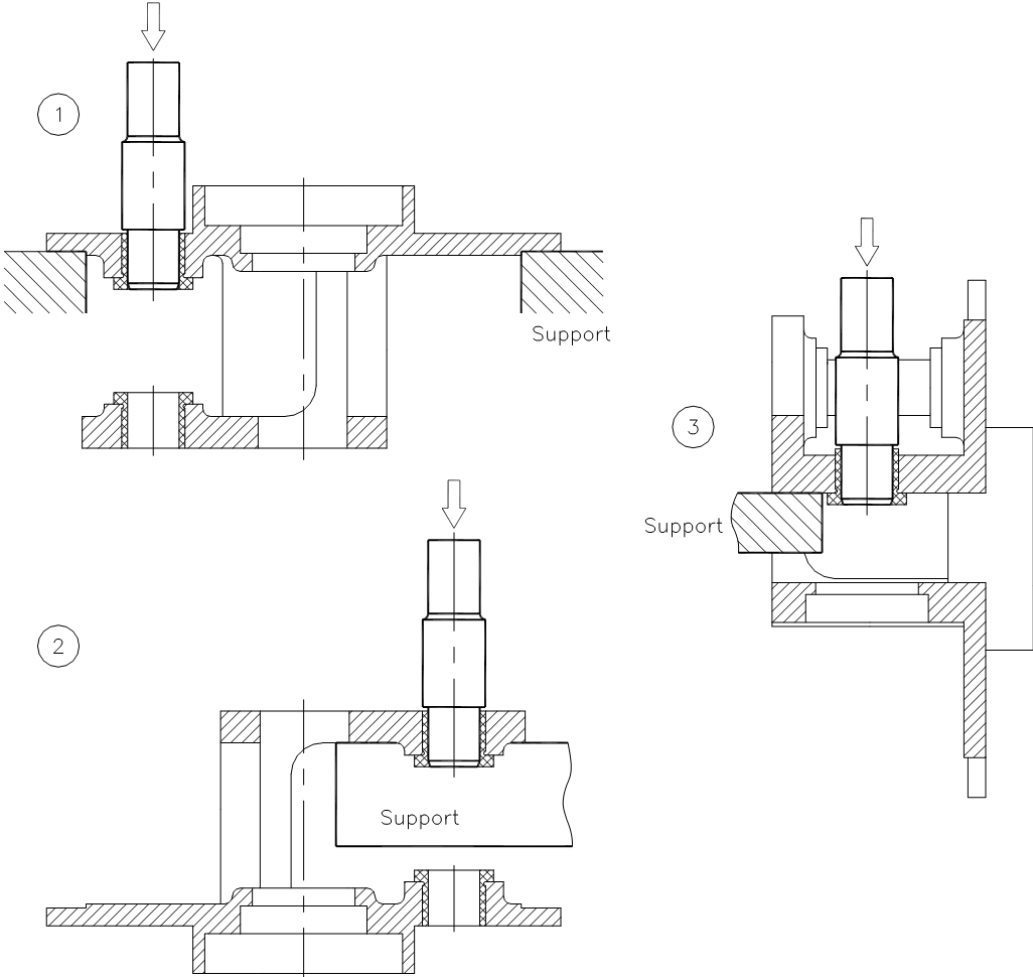

Removal of old Collar bushes

Maintenance and Repair (continued)

Replacement of Ball Races

In body

1. A. With big end downwards knock several times Body with bearings (pos. 26) hard against firm wooden support until Ball race (pos. 26.3) drops out.
1. B. If it is not possible to knock out Ball race in this way , it is necessary first to screw out Main collar lower (pos. 26.2) – see page 40. Carefully push off old Ball race without damaging Main collar lower. Use mandrel and firm support.

Before mounting of new Ball race, Main collar lower (pos. 26.2) must be remounted into Body – see page 40.

2. Clean surfaces and place Ball race (pos. 26.3) on Main collar lower (pos. 26.2). Press by hand as long as possible. By means of a tube mandrel or if desired wooden block, carefully hammer Ball races home.

Ball races must not project over end face of Main collar lower. To avoid tilting mandrel must push along the whole circumference of Ball race. Do not damage surface of Ball race.

On Gear wheel

1. Place Gear wheel with ball race (pos. 7) on support. Support only under Ball race (pos. 7.1). With mandrel press off old Ball race.
2. Clean surfaces and press on new Ball race. Ball race must be pressed fully home on Gear. Press parallel. Use press or vice. Do not damage surface of Ball race.

In Hub cover

1. Place Hub cover with ball race (pos. 19) on support. Carefully knock out old Ball race by means of small mandrel or if desired screwdriver. Knock several times around the circumference to avoid tilting.
2. Clean surfaces and press in new Ball race. Ball race must be pressed fully home. Press parallel. Do not damage surface of Ball race.

Maintenance and Repair (continued)

Replacement of Ball races

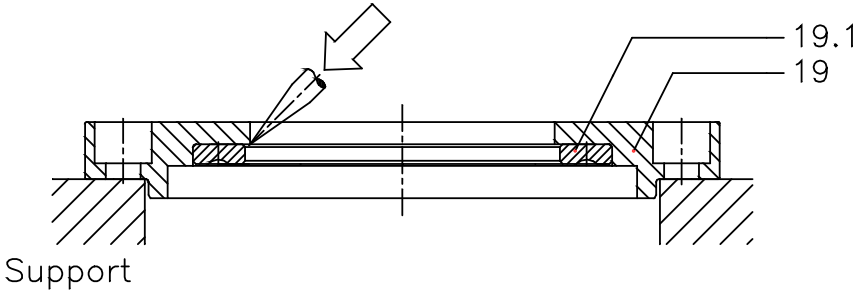
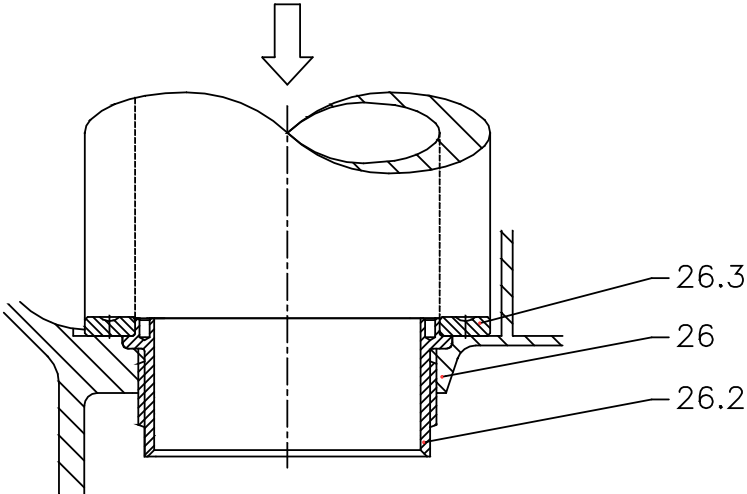
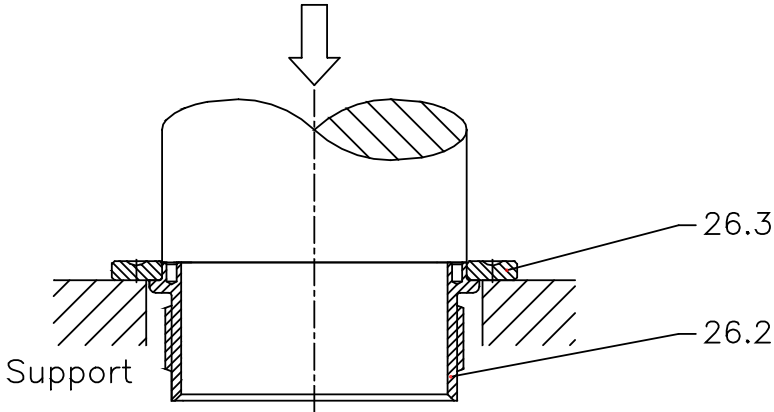

Maintenance and Repair (continued)

Replacement of Main Collars

Although normally exposed to very limited wear, it is possible to replace Main collars (pos. 26.1 and 26.2) and Hub liner (pos. 26.4) in Body. The procedure to do this is described below.

Main collar upper

1. Place Body (pos. 26) in a vice upright position. Do not clamp on machined faces. Insert tool (see page 43) into Main collar upper (pos. 26.1). Unscrew Main collar.
2. Carefully clean thread and recess in Body. Do not damage special thread in Body. Recess must be absolutely clean.
3. Make sure that new Main collar is clean and free from impurities.
4. Screw in new Main collar. Attention should be given to make sure that thread is in correct engagement before screwing in Main collar.
5. Tighten Main collar fully home and tighten up.
6. Check that Main collar is fully home: install Stem, Ball retainer with balls and Gear wheel (see page 32). Check that there is sufficient axial clearance to allow for free rotation of Stem.

Main collar lower

1. Place Body in a vice in upside down position, and repeat procedure described above.

Warning: Thread on Main collar lower is left-handed.



Hub Liner

1. Place Body in a vice. Insert two ordinary screwdrivers behind Hub liner and press it out.
2. Push on new Hub liner.

Maintenance and Repair (continued)

Replacement of Main Collars

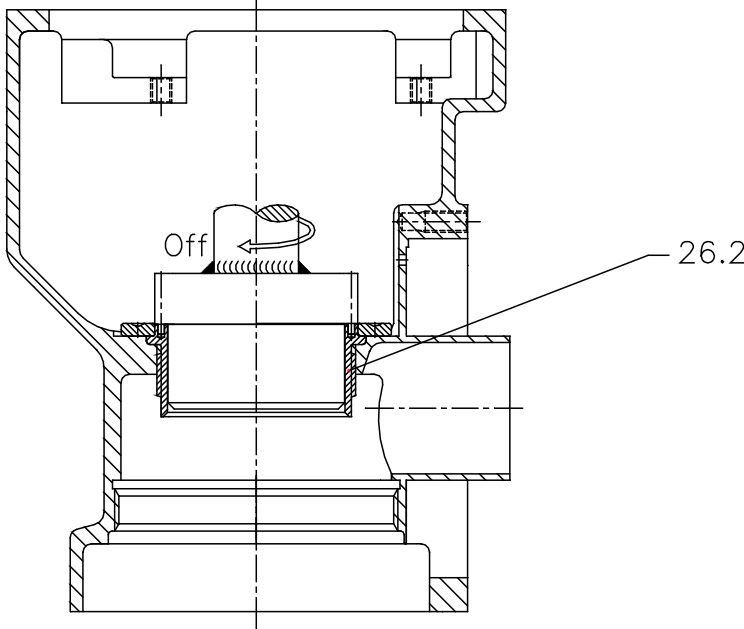
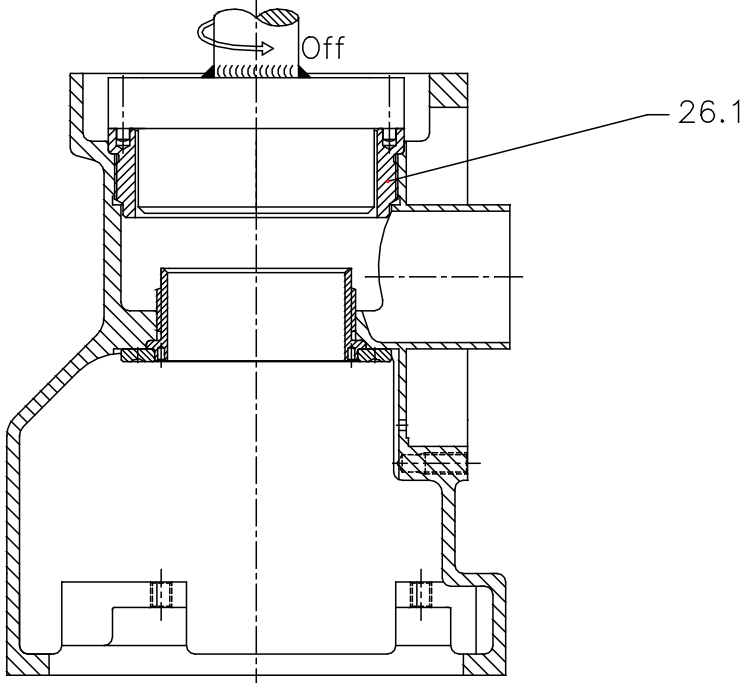

Tools

Standard Tool kit for Toftejorg TZ-74

Article No. TE81B055

Tool No.	Description	No.
TE134	Hex Key for Screw	1
TE134A	Hex Screwdriver for Screw	2
TE462A	Socket wrench for Hex Screw	1

Available on request:

TE81B033 Pusher for 1½" Collar bush

TE81B034 Fixture set f. Collar bush

Sketch of Tools for replacement of Collar bush:

TE81B033 Pusher for 1½" Collar bush:

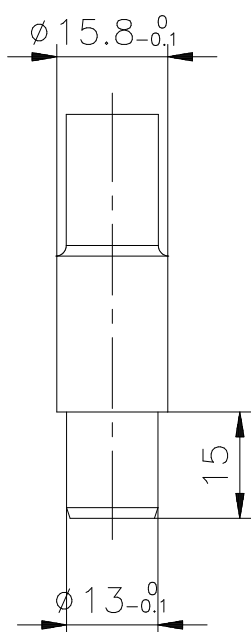

TE81B034: Fixture set f. Collar bush

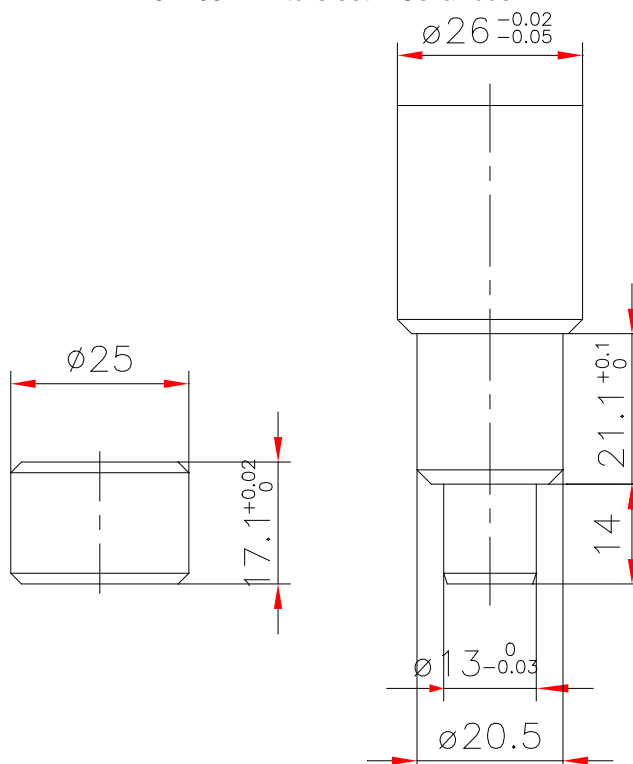

Tools (continued)

Sketch of tools for replacement of Main collars

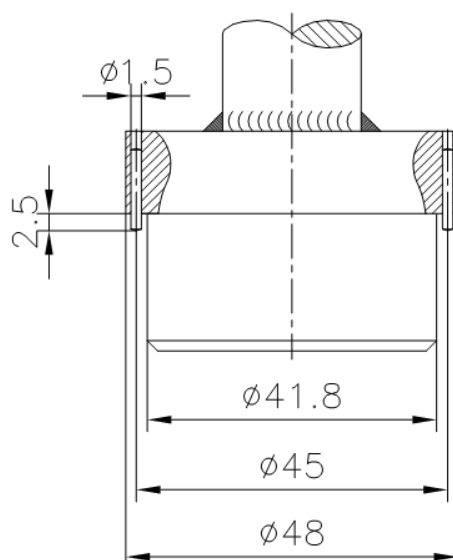
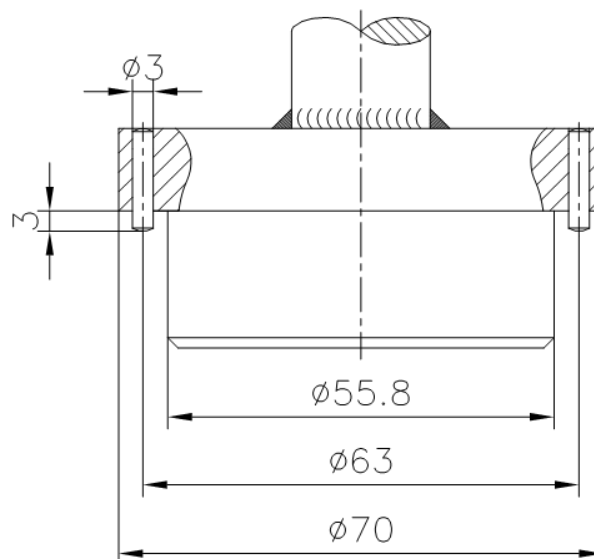

Trouble Shooting Guide

Symptom: Slow rotation or failure of machine to rotate

Possible Causes	Fault finding
No or insufficient liquid flow	<p>a). Check if supply valve is fully open</p> <p>b). Check if inlet pressure to machine is correct</p> <p>c). Check supply line and filter for restriction/clogging</p> <p>d). Remove Nozzles and check for clogging. If blocked, carefully clean Nozzle without damaging stream straighteners and Nozzle tip.</p> <p>e). Remove Top cone Guide and Impeller (see page 26) and check for clogging in Impeller area.</p> <p>If large particles repeatedly get jammed in the machine, install filter or reduce mesh size of installed filter in supply line.</p>
Foreign material or material build-up	<p>Insert hex Screwdriver in Screw in top of Turbine shaft and easily turn Turbine shaft clockwise. If any resistance is recognised, disassemble machine in order to localise the cause:</p> <p>a). Impeller jammed Remove Guide and Impeller (see page 26) and remove foreign material.</p> <p>b). Turbine shaft - sluggish in Main bush Remove Turbine shaft (see page 28) and clean Main bush.</p> <p>c). Bevel gears jammed Remove Top cone and Hub Subassembly (see page 30). Clean teeth on Stem and Bevel gear.</p> <p>d). Stem jammed/sluggish Remove Gear subassembly (see page 28). Check free rotation of Stem. Remove Stem (see page 32). Remove foreign material/material build-up on Stem and inside Main collars. Clean Ball races and Ball retainer with balls. Also clean main bush.</p>

Trouble Shooting Guide (continued)

Possible Causes	Fault finding
e). Gearbox jammed/sluggish	Remove foreign material from Gearbox. Check rotation of shafts. If restriction is recognized, disassemble gearbox (see page 34) and remove material build up, especially on 2. Stage Worm wheel and mating Collar bushes.
f). Hub jammed/sluggish	Disassemble Hub Subassembly (see page 30). Remove foreign material inside Hub. Clean Ball races and Ball retainer with balls. Also clean nose of Body.
Wear	
a). Slide bearings	See page 24.
b). Main bush	See page 25.
c). Worm wheels	See page 25.
d). Collar bushes	See page 24.
e). Turbine shaft	Check clearance in Main bush and in Slide bearing. Transverse movement should not exceed 0.5 mm. Also inspect Worm wheel for wear.
f). Horizontal shaft	Check clearance in Collar bushes. Transverse movement should not exceed 0.5 mm. Also inspect worm for wear.
Mechanical defects	
a). Worm wheels. Teeth broken	Replace Worm wheel.
b). Worm wheel can rotate on Horizontal shaft/Pinion due to damaged driver faces	Replace Worm wheel.
c). Damaged teeth on gear	Inspect teeth on Stem and Bevel gear for deformation. Mount Hub and Stem in Body (see page 30 and 32). Hold Body in upside down position and rotate Hub to check that Bevel gears can work together. If damaged: Replace Stem and/or Bevel gear.

Reference List of Parts for Toftejorg TZ-74

Pos.	Ref.No.	No/Unit	Description	Material	Remarks
1	<input type="checkbox"/> TE21D500	1	Top Cone 1½" BSP	Stainless steel	Spare part
	<input type="checkbox"/> TE21D501	1	Top Cone 1½" NPT	Stainless steel	Spare part
	<input type="checkbox"/> TE21D511	1	Top Cone 2" NPT	Stainless steel	Spare part
2	<input type="checkbox"/> TE703	1	Guide 100%	Stainless steel	Spare part
	<input type="checkbox"/> TE803-0	1	Guide ring 0%	Stainless steel	Spare part
3	TE21B526	1	Stem	Stainless steel	Spare part
4	TE705	1	Impeller 100%	Stainless steel	Spare part
5	TE21A525	1	Main bush	Polymer	Wear part
6	TE411K	1	Turbine shaft	Stainless steel	Wear part
7	TE712-13	1	Gear wheel w. ball race	Stainless steel	Spare part
7.1	TE826-1		Ball race	Stainless steel	Wear part
9	TE814	1	Pinion	Stainless steel	Spare part
10	TE21A585	3	Collar bush	Polymer	Wear part
11+33	TE21A367	2	Worm wheel w. reinforcem.	Polymer	Wear part
12	TE817	1	Journal	Stainless steel	Spare part
13	TE719A	4	Washer	Stainless steel	Spare part
14	TE731	2	Bearing cover	Stainless steel	Spare part
15	TE118	22	Screw	Stainless steel	Spare part
16	TE156	8	Spring washer	Stainless steel	Spare part
17	TE402H	6	Hex Screw	Stainless steel	Spare part
18	TE722S	1	Bevel gear w. ball race	Stainless steel	Spare part
18.1	TE826-1		Ball race	Stainless steel	Wear part
19	TE21D340	1	Hub cover w. ball race	Stainless steel	Spare part
19.1	TE826-1		Ball race	Stainless steel	Wear part
20	<input type="checkbox"/> TE50A006	4	Nozzle, ø6 mm	Stainless steel	Spare part
	<input type="checkbox"/> TE50A007	4	Nozzle, ø7 mm	Stainless steel	Spare part
	<input type="checkbox"/> TE50A008	4	Nozzle, ø8 mm	Stainless steel	Spare part
	<input type="checkbox"/> TE50A010	2	Nozzle, ø10 mm	Stainless steel	Spare part
20.1	TE50A000	2	Plug	Stainless steel	Spare part
21	TE21C536	1	Hub	Stainless steel	Spare part
24	TE21A380	2	Ball retainer w. balls	Polymer/Stainless steel	Spare part
25	TE21D562	1	Hub gasket	Polymer/elastomer	Spare part
26	TE727Z4	1	Body	Stainless steel	Not available
26.1	TE21B520	1	Main collar upper	Polymer	Wear part
26.2	TE21B521	1	Main collar lower	Polymer	Wear part
26.3	TE826-1	1	Ball race	Stainless steel	Wear part
26.4	TE21D522	1	Hub liner	Polymer	Wear part
27	TE828Z	1	Horizontal shaft	Stainless steel	Wear part
28	TE21A570	2	Slide bearing	Polymer	Wear part
29	TE730	1	Gear frame	Stainless steel	Spare part
30	TE21D350	1	Bottom cover compl.	Stainless steel	Spare part
31	TE421H	10	Hex Screw	Stainless steel	Spare part
32	TE21D563	1	Bottom gasket	Polymer/elastomer	Spare part
33	TE21A367		See pos. 11		

Configuration as delivered marked

Please note that some of the polymer parts are in PEEK, which is not resistant to concentrated sulfuric acid.

Cross Sectional Drawing for Toftejorg TZ-74

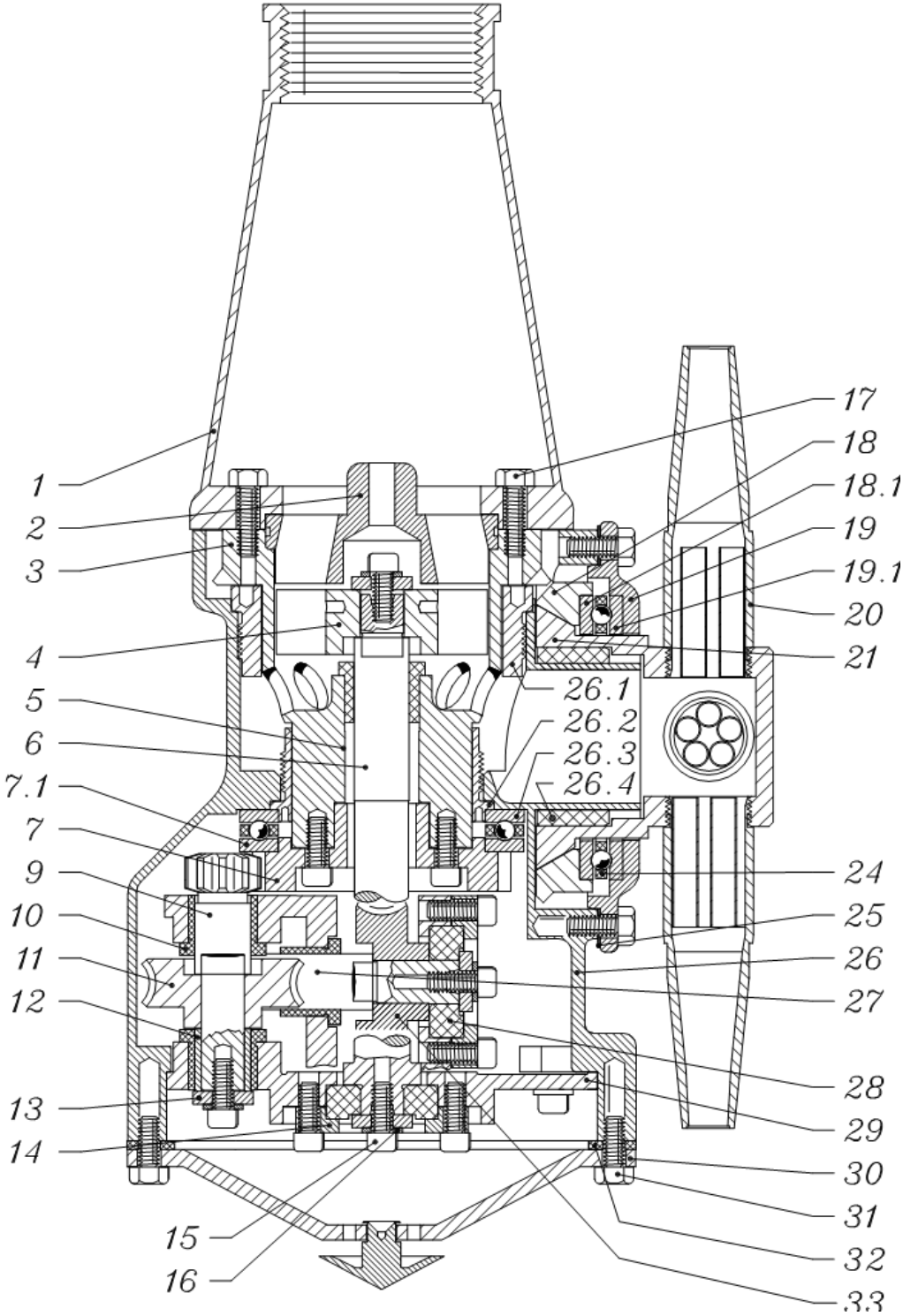

Reference List of Parts for Toftejorg TZ-74 Self-cleaning

Pos.	Ref. No.	No/Unit	Description	Material	Remarks
1	<input type="checkbox"/> TE21D500	1	Top Cone 1½" BSP	Stainless steel	Spare part
	<input type="checkbox"/> TE21D501	1	Top Cone 1½" NPT	Stainless steel	Spare part
	<input type="checkbox"/> TE21D511	1	Top Cone 2" NPT	Stainless steel	Spare part
2	<input type="checkbox"/> TE703	1	Guide 100%	Stainless steel	Spare part
	<input type="checkbox"/> TE803-0	1	Guide ring 0%	Stainless steel	Spare part
3	TE21D561	1	Stem f. Toftej.TZ-74 self-clean	Stainless steel	Spare part
4	TE705	1	Impeller 100%	Stainless steel	Spare part
5	TE21A525	1	Main bush	Polymer	Wear part
6	TE411K	1	Turbine shaft	Stainless steel	Wear part
7	TE712-13	1	Gear wheel w. ball race	Stainless steel	Spare part
7.1	TE826-1		Ball race	Stainless steel	Wear part
9	TE814	1	Pinion	Stainless steel	Spare part
10	TE21A585	3	Collar bush	Polymer	Wear part
11+33	TE21A367	2	Worm wheel w. reinforcem.	Polymer	Wear part
12	TE817	1	Journal	Stainless steel	Spare part
13	TE719A	4	Washer	Stainless steel	Spare part
14	TE731	2	Bearing cover	Stainless steel	Spare part
15	TE118	22	Screw	Stainless steel	Spare part
16	TE156	8	Spring washer	Stainless steel	Spare part
17	TE402H	6	Hex Screw	Stainless steel	Spare part
18	TE722S	1	Bevel gear w. ball race	Stainless steel	Spare part
18.1	TE826-1		Ball race	Stainless steel	Wear part
19	TE21D340	1	Hub cover w. ball race	Stainless steel	Spare part
19.1	TE826-1		Ball race	Stainless steel	Wear part
20	<input type="checkbox"/> TE50A006	4	Nozzle, ø6 mm	Stainless steel	Spare part
	<input type="checkbox"/> TE50A007	4	Nozzle, ø7 mm	Stainless steel	Spare part
	<input type="checkbox"/> TE50A008	4	Nozzle, ø8 mm	Stainless steel	Spare part
	<input type="checkbox"/> TE50A010	2	Nozzle, ø10 mm	Stainless steel	Spare part
20.1	TE50A000	2	Plug	Stainless steel	Spare part
21	TE21C536	1	Hub	Stainless steel	Spare part
24	TE21A380	2	Ball retainer w. balls	Polymer/Stainless steel	Spare part
25	TE21D562	1	Hub gasket	Polymer/elastomer	Spare part
26	TE21D560	1	Body w. clean nozzle	Stainless steel	Not available
26.1	TE21B520	1	Main collar upper	Polymer	Wear part
26.2	TE21B521	1	Main collar lower	Polymer	Wear part
26.3	TE826-1	1	Ball race	Stainless steel	Wear part
26.4	TE21D522	1	Hub liner	Polymer	Wear part
27	TE828Z	1	Horizontal shaft	Stainless steel	Wear part
28	TE21A570	2	Slide bearing	Polymer	Wear part
29	TE730	1	Gear frame	Stainless steel	Spare part
30	TE21D350	1	Bottom cover compl.	Stainless steel	Spare part
31	TE421H	10	Hex Screw	Stainless steel	Spare part
32	TE21D563	1	Bottom gasket	Polymer/elastomer	Spare part
33	TE21A367		See pos. 11		

Configuration as delivered marked

Please note that some of the polymer parts are in PEEK, which is not resistant to concentrated sulfuric acid.

Cross Sectional Drawing for Toftejorg TZ-74 Self-cleaning

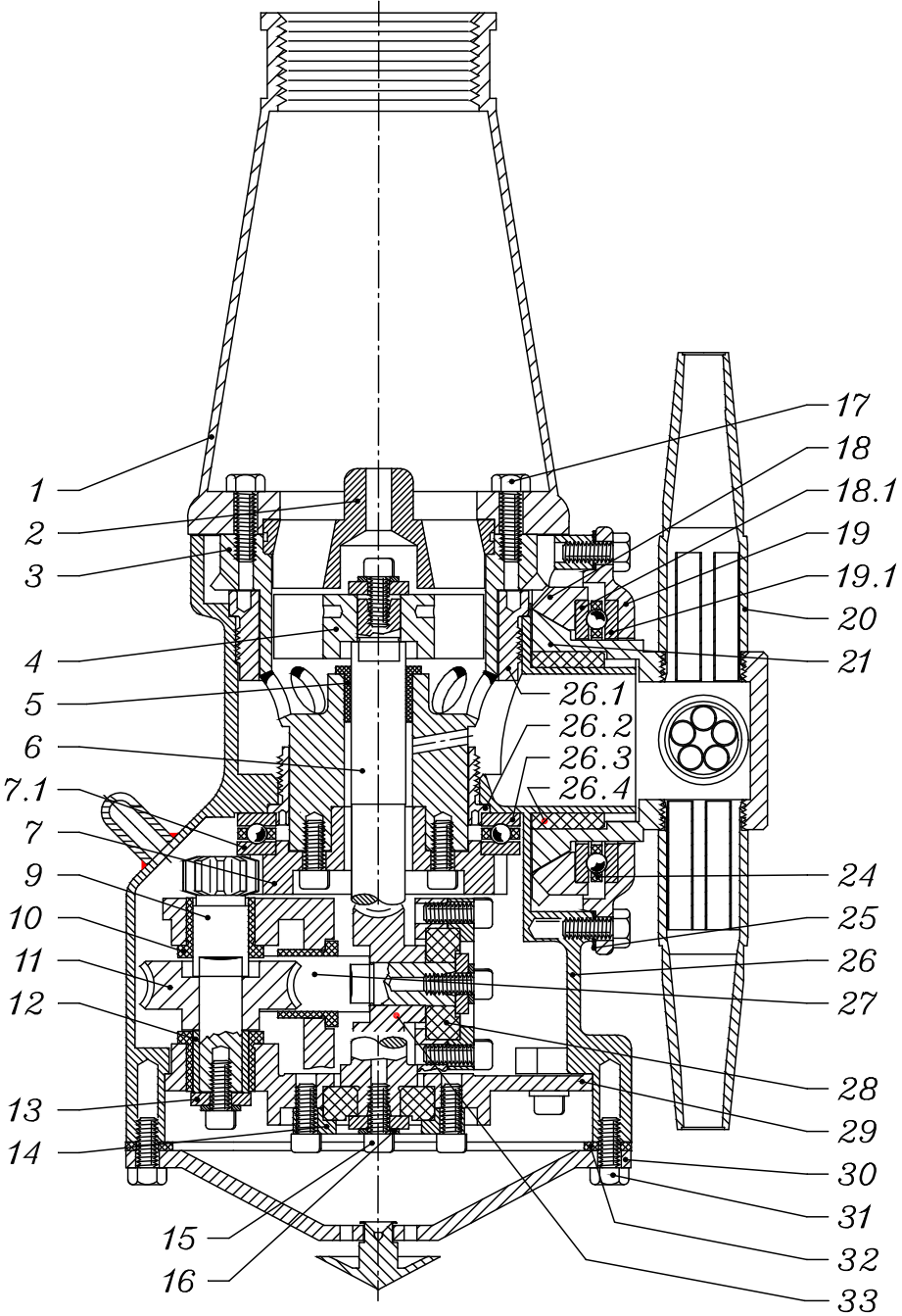

Reference List of Parts for Toftejorg TZ-74 w. Hub deflector

Pos.	Ref. No.	No/Unit	Description	Material	Remarks
1	<input type="checkbox"/> TE21D500	1	Top Cone 1½" BSP	Stainless steel	Spare part
	<input type="checkbox"/> TE21D501	1	Top Cone 1½" NPT	Stainless steel	Spare part
2	<input type="checkbox"/> TE703	1	Guide 100%	Stainless steel	Spare part
	<input type="checkbox"/> TE803-0	1	Guide ring 0%	Stainless steel	Spare part
3	TE21D561	1	Stem f. Toftej.TZ-74 self-clean	Stainless steel	Spare part
4	TE705	1	Impeller 100%	Stainless steel	Spare part
5	TE21A525	1	Main bush	Polymer	Wear part
6	TE411K	1	Turbine shaft	Stainless steel	Wear part
7	TE712-13	1	Gear wheel w. ball race	Stainless steel	Spare part
7.1	TE826-1		Ball race	Stainless steel	Wear part
9	TE814	1	Pinion	Stainless steel	Spare part
10	TE21A585	3	Collar bush	Polymer	Wear part
11+33	TE21A367	2	Worm wheel w. reinforcem.	Polymer	Wear part
12	TE817	1	Journal	Stainless steel	Spare part
13	TE719A	4	Washer	Stainless steel	Spare part
14	TE731	2	Bearing cover	Stainless steel	Spare part
15	TE118	22	Screw	Stainless steel	Spare part
16	TE156	8	Spring washer	Stainless steel	Spare part
17	TE402H	6	Hex Screw	Stainless steel	Spare part
18	TE722S	1	Bevel gear w. ball race	Stainless steel	Spare part
18.1	TE826-1		Ball race	Stainless steel	Wear part
19	TE21D340	1	Hub cover w. ball race	Stainless steel	Spare part
19.1	TE826-1		Ball race	Stainless steel	Wear part
20	<input type="checkbox"/> TE50A007	4	Nozzle, ø7 mm	Stainless steel	Spare part
	<input type="checkbox"/> TE50A008	4	Nozzle, ø8 mm	Stainless steel	Spare part
21	TE21C310	1	Hub kit with deflector	Stainless steel	Spare part
24	TE21A380	2	Ball retainer w. balls	Polymer/Stainless steel	Spare part
25	TE21D562	1	Hub gasket	Polymer/elastomer	Spare part
26	TE21C540	1	Body	Stainless steel	Not available
26.1	TE21B520	1	Main collar upper	Polymer	Wear part
26.2	TE21B521	1	Main collar lower	Polymer	Wear part
26.3	TE826-1	1	Ball race	Stainless steel	Wear part
26.4	TE21D522	1	Hub liner	Polymer	Wear part
27	TE828Z	1	Horizontal shaft	Stainless steel	Wear part
28	TE21A570	2	Slide bearing	Polymer	Wear part
29	TE730	1	Gear frame	Stainless steel	Spare part
30	TE21D350	1	Bottom cover compl.	Stainless steel	Spare part
31	TE421H	10	Hex Screw	Stainless steel	Spare part
32	TE21D563	1	Bottom gasket	Polymer/elastomer	Spare part
33	TE21A367		See pos. 11		

Configuration as delivered marked

Please note that some of the polymer parts are in PEEK, which is not resistant to concentrated sulfuric acid.

Cross Sectional Drawing for Toftejorg TZ-74 w. Hub deflector

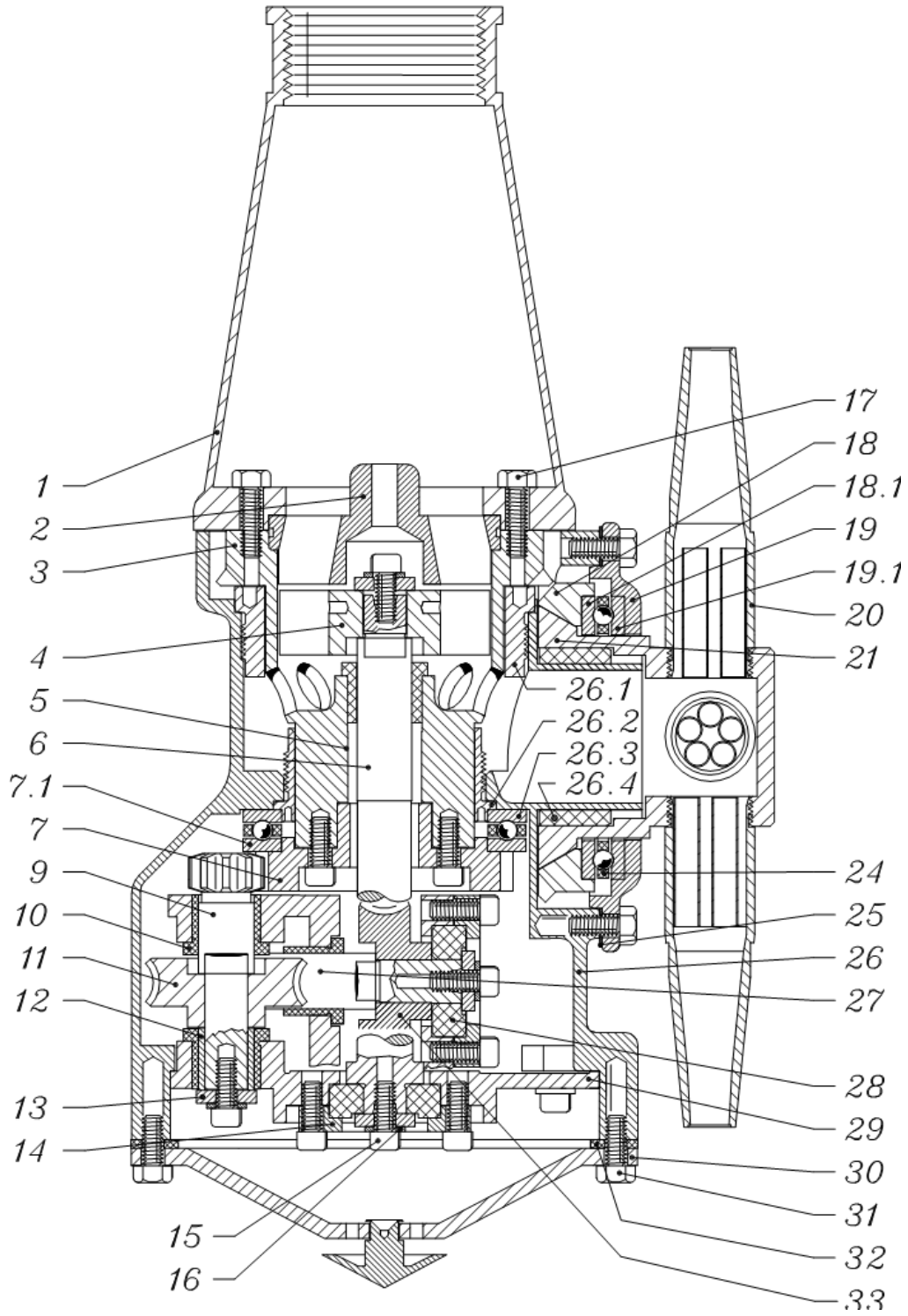

Service Kits

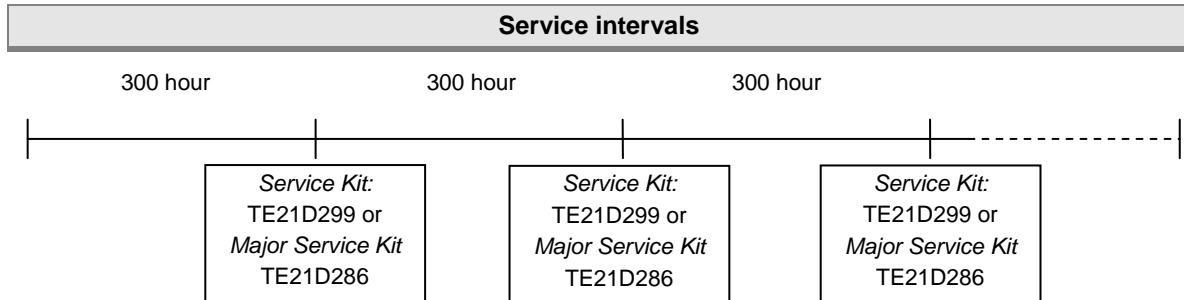

Service Kit for Toftejorg TZ-74 & TZ-74 Self-cleaning, article no. TE21D299		
Part No.	Description	No.
TE21A367	Worm wheel	2 pcs.
TE21A525	Main bush	1 pcs.
TE21A570	Slide bearing	2 pcs.
TE21A585	Collar bush	3 pcs.

Major Service Kit for Toftejorg TZ-74 & TZ-74 Self-cleaning, article no. TE21D286		
Part No.	Description	No.
TE21A525	Main bush	1 pcs.
TE21A570	Slide bearing	2 pcs.
TE21A367	Worm wheel	2 pcs.
TE411K	Turbine shaft	1 pcs.
TE826-1	Ball race	4 pcs.
TE21A380	Ball retainer w. balls	2 pcs.
TE21A585	Collar bush	3 pcs.
TE828Z	Horizontal shaft	1 pcs.
TE21D522	Hub collar	1 pcs.

Standard Tool kit for Toftejorg TZ-74, article no. TE81B055		
Tool No.	Description	No.
TE134	Hex Key for Screw	1 pcs.
TE134A	Hex Screwdriver for Screw	2 pcs.
TE462A	Socket wrench for Hex Screw	1 pcs.

How to order Spare Parts and Claim Procedure

How to Order Spare Parts

On the Cross Sectional Drawings as well as on all instruction drawings, the individual parts have a pos. no., which is the same on all drawings. From the pos. no. the part is easily identified in the Reference Lists of Parts, page 46, 48 and 50.

Individual parts should always be ordered from the Reference Lists of Parts, page 46, 48 and 50. Ref. no. and description should be clearly stated.

Please also quote the type of machine and serial no. This will help us to help you. The type and serial nos. are stamped on the Body of the tank cleaning machine.

Claim Procedure

In case of failure that needs assistance from Alfa Laval Tank Equipment A/S, it is essential for our evaluation that the problem as well as the working conditions of the machine are described as detailed as possible.

For description of the working conditions, fill in copy of Claim Report - Working Conditions, which you will find at the back of this manual.

How to contact Alfa Laval Tank Equipment A/S

For further information please feel free to contact:

Alfa Laval Tank Equipment A/S
Baldershoej 19
P.O. Box 1149
2635 Ishoej
Denmark

Phone no.: +45 43 55 86 00
Fax no.: +45 43 55 86 01
www.alfalaval.com
www.toftejorg.com

Contact details for all countries are continually updated on our websites.

Service Card

Type of Machine : _____

Serial No. : _____

Configuration : Nozzle diameter : _____ mm
 Impeller : _____ %
 Guide : _____ %

Date	No. of Working Hours	Maintenance Actions/ Exchanged Parts	Remarks	Sign.
	0	Machine put into operation		

Vers. 942

Claim Report Working Conditions

Page 1/2

Ref. Claim Case : _____

Machine/Cleaner Type : _____ Serial No.: _____

Configuration

- Nozzles : _____ x \emptyset _____ mm
 - Turbine/Inlet Guide : _____ % _____

Working Conditions

Inlet pressure at machine/cleaner : _____
 Type of Valve in inlet line : _____
 Can hydraulic shock be disregarded: : Yes No
 Inlet line flushed before installation of tank cleaner? : Yes No
 Working hours before failure : _____ hours

Cleaning Programme

Cleaning media and conc.	Temperature	Time	Recirculation?

Is sterilising being used? : Yes No
 Procedure (media/temp.)? : _____
 Is steam injection being used for heating? : Yes No
 Time: _____
 Temperature: _____

v. 98.1

Claim Report Working Conditions (continued)

Page 2/2

Condition of Cleaning Media

- | | |
|---|---|
| <input type="checkbox"/> Clean | |
| <input type="checkbox"/> Contaminated with (nature and description) | |
| <input type="checkbox"/> Chemicals/Solvents _____ | <input type="checkbox"/> High viscous |
| <input type="checkbox"/> Soluble | <input type="checkbox"/> Sticky/tenacious |
| <input type="checkbox"/> Low viscous | <input type="checkbox"/> Solidifying |
| <input type="checkbox"/> Hard particles/size _____ | <input type="checkbox"/> Crystallizing |
| <input type="checkbox"/> Soft particles/size _____ | |

Has filter been installed in inlet line?

- | | |
|------------------------------|----|
| <input type="checkbox"/> Yes | |
| Mesh size: _____ | mm |
| <input type="checkbox"/> No | |

Is tank cleaner flushed with clean water after tank cleaning?

- | | |
|------------------------------|-----------------------------|
| <input type="checkbox"/> Yes | <input type="checkbox"/> No |
|------------------------------|-----------------------------|

Type of Sludge/Tank Contents to be removed

Name, formula/concentration of material to be removed from tank : _____

What is material soluble in : _____

Nature of material:

- | | | |
|---|---|--|
| <input type="checkbox"/> Volatile/explosive | <input type="checkbox"/> Sticky/tenacious | <input type="checkbox"/> Contains soft particles |
| <input type="checkbox"/> Low viscous | <input type="checkbox"/> Solidifying | <input type="checkbox"/> Contains hard particles |
| <input type="checkbox"/> High viscous | <input type="checkbox"/> Crystallizing | |

Is tank cleaner submerged in material?

- | | |
|------------------------------|-----------------------------|
| <input type="checkbox"/> Yes | <input type="checkbox"/> No |
|------------------------------|-----------------------------|

Other information/Remarks

Date: _____

Sign.: _____

EC Declaration of conformity

We

Manufacturer: Alfa Laval Tank Equipment A/S
 Address: Baldershoej 19, DK-2635 Ishoej
 Phone/Fax: Phone: +45 43 55 86 00. Fax: +45 43 55 86 01
 E-mail: tankequipment.info@alfalaval.com

herewith declare that the below mentioned product:

Toftejorg TZ-74

Standard			Self-cleaning			W. Hub deflector		Brew Kettle		
TE21D108	TE21D208	TE21D108	TE21D008	TE21D058	TE21D008	TE21D110	TE21D110	TE21D108	TE21D208	TE21D108
TE21D110	TE21D210	TE21D110	TE21D010	TE21D060	TE21D010	TE21D112	TE21D112	TE21D110	TE21D210	TE21D110
TE-21D112	TE-21D212	TE-21D112	TE21D028	TE21D078	TE21D028	TE21D130	TE21D130	TE21D112	TE21D212	TE21D112
TE21D128	TE21D228	TE21D128	TE21D030	TE21D080	TE21D030	TE21D210	TE21D210	TE21D130	TE21D230	TE21D130
TE21D130	TE21D230	TE21D130	TE21D032	TE21D082	TE21D032	TE21D212	TE21D212			
TE21D132	TE21D232	TE21D132				TE21D230	TE21D230			

is in conformity with the provisions of:

- The Machinery Directive 2006/42/EC, Annex II, Paragraph 1, Part A
- The Equipment explosive atmospheres (ATEX) Directive 94/9/EC.
- The Pressure Directive 97/23/EC
- FDA 21CFR§177

Harmonised European Standards:

The machine is manufactured in accordance with the relevant clauses of the following standards:

The Machinery Directive:

DS/EN ISO 12100-1, DS/EN ISO 12100-2, EN 1672-2

The pressure directive:

According to its own volume and the rated pressure range the product is regarded an Article 3, par. 3 Equipment.

EC Declaration of conformity

The ATEX-Directive:

For machines with item nos. TE21DXXX-7X
DS/EN 1127-1, DS/EN 13463-1, DS/EN 13463-5,
DS/EN 13980 Annex A, paragraph A.5.3 Rotating machines

ATEX Certification:

EC Type Examination Certificate no. Baseefa10ATEX0188X

Marking:  II 1 GD c T175°C Tamb 0°C to +140°C

Baseefa (2001) Ltd., Notified Body number 1180. Rockhead Business Park
Staden Lane, Buxton, Derbyshire SK17 9RZ, United Kingdom

Place: Ishoej, Denmark

Date: December 21, 2011

Signature:



Name and title:

Henrik Falster Hansen
R&D Manager

Place: Ishoej, Denmark

Date: December 21, 2011

Signature:



Name and title:

Denniz Høxbroe
ATEX responsible engineer

How to contact Alfa Laval

Contact details for all countries are continually updated on our website.

Please visit www.alfalaval.com to access the information directly.

© Alfa Laval Corporate AB

This document and its contents is owned by Alfa Laval Corporate AB and protected by laws governing intellectual property and thereto related rights. It is the responsibility of the user of this document to comply with all applicable intellectual property laws. Without limiting any rights related to this document, no part of this document may be copied, reproduced or transmitted in any form or by any means (electronic, mechanical, photocopying, recording, or otherwise), or for any purpose, without the expressed permission of Alfa Laval Corporate AB. Alfa Laval Corporate AB will enforce its rights related to this document to the fullest extent of the law, including the seeking of criminal prosecution.