



SSB Retractor Stroke 120 Air-to-Spring 98mm Mounting

Models: TE75P233, TE75P233-04, TE75P253 & TE75P253-04

- Covering**
- **Standard Machines**
 - **Machines delivered with ATEX Certification in accordance with Directive 94/9/EC**



IM-TE91A908-EN1

ESE02202

Date of issue: January 19, 2012
First published: January 19, 2012

Contents

Contents	1
Introduction	3
Intended Use	4
Patents and trademarks	4
ATEX Marking	5
Design Overview	5
Applications	6
Options	6
SSB Retractor Unit in extended position	7
Accessories	8
Technical Data.....	9
Materials	9
Connections.....	9
Available add-ons (documentation).....	10
Flow Rate Data.....	11
Installation dimensions and connections.....	12
Dimensions	12
Installation	14
General Safety and Installation Instructions.....	15
Special Conditions for Safe Use in accordance with the ATEX Certification, Directive 94/9/EC.....	16
Warnings	20
Fluid and air connections	20
Important recommendation for installation	20
Service and Repair of ATEX Approved Machines	21
Recommended Service Intervals	21
Component parts	22
List of Parts.....	22
Parts drawing.....	23
Maintenance	24
Dismantling the Unit for Inspection	24
Re-Build & fitment of New Service Repair Kit	33
Standard Service Kit and Tools.....	46
How to order Spare Parts and Claim Procedure.....	48
How to contact Alfa Laval Tank Equipment A/S.....	48
EC Declaration of Conformity.....	49
ATEX-Special Conditions for safe use	51

Introduction

The SSB Retractor is a pneumatically operated targeted spray ball which has been designed to achieve fast effective cleaning of all equipment used in the production process, including Ductwork, Vent Lines, Cyclones and many other applications where access is impossible

This manual has been prepared as a guide for the persons who will be operating and maintaining your tank cleaning machine. The key to long life for your tank cleaning machine will always be a system of carefully planned maintenance; you will appreciate that a tank cleaning machine which has a rough and dirty job to do will need more frequent attention than one working in ideal conditions.

It is in your own interest to get the best and most economical performance from your tank cleaning machine. Neglect of maintenance means poor performance, unscheduled stoppages, shorter life and expense. Good maintenance means good performance; no unscheduled stoppages and better total economy.

You will find the information contained in this manual simple to follow, but should you require further assistance, our Customer Service Department and world-wide net of Distributors will be pleased to help you. Please quote the type and serial number with all your enquiries; this will help us to help you.

The type and serial number are placed on the side of the body of the tank cleaning machine.

Note: The illustrations and specifications contained in this manual were effective at the date of printing. However, as continuous improvements are our policy, we reserve the right to alter or modify any unit specification on any product without prior notice or any obligation.

© 2012 Alfa Laval Corporate AB

This document and its contents is owned by Alfa Laval Corporate AB and protected by laws governing intellectual property and thereto related rights. It is the responsibility of the user of this document to comply with all applicable intellectual property laws. Without limiting any rights related to this document, no part of this document may be copied, reproduced or transmitted in any form or by any means (electronic, mechanical, photocopying, recording, or otherwise), or for any purpose, without the expressed permission of Alfa Laval Corporate AB. Alfa Laval Corporate AB will enforce its rights related to this document to the fullest extent of the law, including the seeking of criminal prosecution.

Intended Use

It is to be verified by the end-user:

- that the tank cleaning machine is in conformity with respect to tank, vessel, container or duct size in which it will be used.
- that the construction materials (both metallic and non-metallic) are compatibility with product, flushing media, cleaning media, temperatures and pressure under the intended use.

Patents and trademarks

This Instruction Manual is published by Alfa Laval Tank Equipment A/S without any warranty. Improvements and changes to this Instruction Manual may at any time be made by Alfa Laval Tank Equipment A/S without prior notice. Such changes will, however, be incorporated in new editions of this Instruction Manual.

© Alfa Laval Tank Equipment A/S, 2012. All rights reserved.

The Alfa Laval logotype is a trademark or a registered trademark of Alfa Laval Corporate AB. "Toftejorg" is a trademark or registered trademark of Alfa Laval Tank Equipment A/S. Other products or company names mentioned herein may be the trademarks of their respective owners. Any rights not expressly granted herein are reserved

If ordered with ATEX certificate: ATEX Marking

The SSB Retractor - Mini Retract-A-Ball is certified as category I components. The certification is carried out by the notified body Baseefa, who has issued the certificate Baseefa 11ATEX0231X. The marking on the ATEX certified SSB Retractor - Mini Retract-A-Ball is as follows:

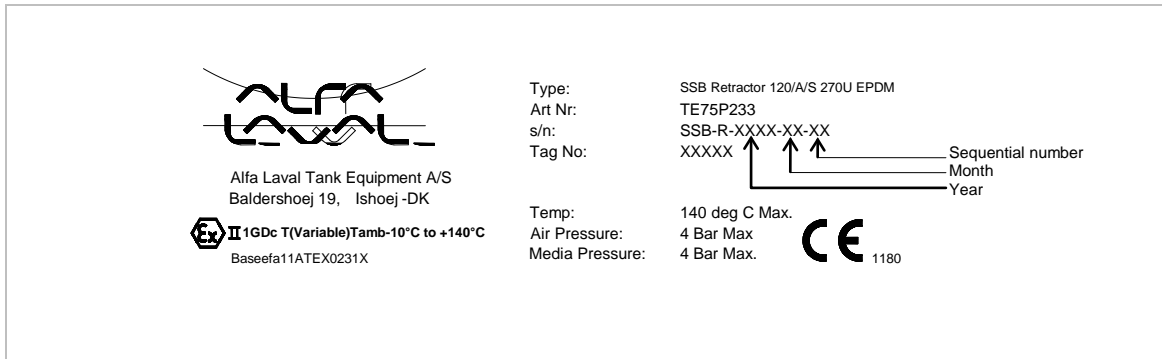

Note:

TE75P233-04 and TE75P253-04

These machines are approved for 180°C max: Tamb -10°C to +180°C.

Changes to the machine are not allowed without approval by the person responsible for the ATEX certification at Alfa Laval Tank Equipment A/S. If changes are made – or spare parts other than Alfa Laval original spare parts are used - the EC Type Examination certification (the ATEX Directive) is no longer valid.

Important ATEX information:



Also see page 19 regarding special conditions for repair of ATEX certified machines.

Design Overview

The unit has been specifically designed to ensure good self draining so that there is no hold up of cleaning media after operation; this is achieved by a sealed cleaning housing and telescopic actuation and air cylinder design which ensures the minimum surface area becomes wetted. No media enters the spring chamber. After operation the SSB Retractor can be held open pneumatically while the spray stem self drains before closure by the return spring. This provides the opportunity to purge the spray stem if required.

Applications

The SSB Retractor can be used to clean from simple tanks and ductwork, to complex process applications with agitators where it is not possible to use fixed spray balls. Applications such as Storage Tanks, Reactors, Mixers and Spray Dryers including Ductwork and Vent Lines can all be cleaned by use of one or multiple SSB Retractor units.

ATEX Warning: The speed at which the Sprayball is deployed (extended to the open position) must not exceed 0.5m/s. Ensure that the control air pressure is regulated to 4 bar max.



Options

The units are available in a range of operating strokes. As standard there are two sizes of SSB Retractor—60mm and 120mm. However, both units can be adjusted during manufacture by increments of 10mm. This allows the units to be fine tuned to accurately position the spray ball optimising the effectiveness.

As standard the units are available with all machined components in 316L Stainless Steel and standard seals in EPDM and Carbon filled PTFE. However, the units are available with wetted components in Hastelloy C22 and seals manufactured from Perfluorolastomer should the environment require.

The spray balls are offered with standard spray patterns or can be target drilled to direct cleaning to certain features such as access covers etc.

SSB Retractor Unit in extended position



Figure 1 SSB, extended position

Accessories

The unit can be supplied with proximity sensors to indicate that the unit is either fully open, fully closed, or both. If this option is required, a sensor part number: TE75P507 will be required for each position.

If the SSB Retractor is being ordered with ATEX Certification it is important to note that if a sensor is fitted the ATEX Category & Zone in which the SSB Retractor can be used will be effected.

The SSB Retractor is ATEX Category 1 but if sensors are fitted the unit will assume the lower ATEX rating of the Proximity Sensor.

If sensors are required for an ATEX environment please consult Alfa Laval.

**ATEX
Warning:**



It is important to note that the SSB Retractor is ATEX Category 1 for installations in zone 0/20.

However, if Proximity sensors are fitted the overall ATEX rating of the SSB Retractor will assume the lower ATEX rating of the proximity sensor.

Technical Data

Model /Article No.	TE75P233	TE75P233-04
	TE75P253	TE75P253-04

Weight of Unit	: 3.7kg	3.7kg
Operating Air Pressure	: 3.5-4 bar (50-58 psi)	3.5-4 bar (50-58 psi)
Cleaning Fluid Pressure	: 2 - 4 bar (29 - 58 psi)	2 - 4 bar (29 - 58 psi)
Flow Rate Approx.	: 2.8m ³ / hr at 3 bar	2.8m ³ / hr at 3 bar
Max. Cleaning Fluid temp.	: 95° C (203 deg F)	95° C (203 deg F)
Max. Process temp.	: 140° C (284 deg F)	180° C (356 deg F)
Ambient temp.	: -10°C to +140°C (95° C – 140°C - when not operated)	-10°C to +180°C (95° C – 180°C - when not operated)

Materials

Components	: Stainless Steel 316L	Stainless Steel 316L
Spring	: Stainless Steel 301S81	Stainless Steel 301S81
Seals	: EPDM, Carbon Filled PTFE	Isolast-(Perfluorolastomer), Carbon Filled PTFE
Gaskets	: PTFE	PTFE

Connections

Air Connection	: 1/8" BSP Parallel—internal thread is fitted as Standard with 6mm outside diameter push fit Connector.
Cleaning Media Connection	: DIN 10 Flange (DIN 32676)
Vessel Mounting	: DIN 50 Flange (DIN 32676)
Body Tube Joints	: Flanged/Clamped to DIN 40 (DIN 32676)

Technical Data (continued)

Available add-ons (documentation)

TE75P2X3-70	EPDM + ATEX
TE75P2X3-80	EPDM + ATEX + 3.1 cert.
TE75P2X3-90	EPDM + 3.1 cert.
TE75P2X3-74	FFKM + ATEX
TE75P2X3-84	FFKM + ATEX + 3.1 cert.
TE75P2X3-94	FFKM + 3.1 cert.

Explanation to Add-ons:

ATEX includes:

ATEX approved machine for use in explosive atmospheres. Category 1 for installation in zone 0/20 in accordance to Directive 94/9/EC. Ex II 1GD c T(Variable) Tamb -10°C to +140°C or Ex II 1GD c T(Variable) Tamb -10°C to +180°C.

Flow Rate Data

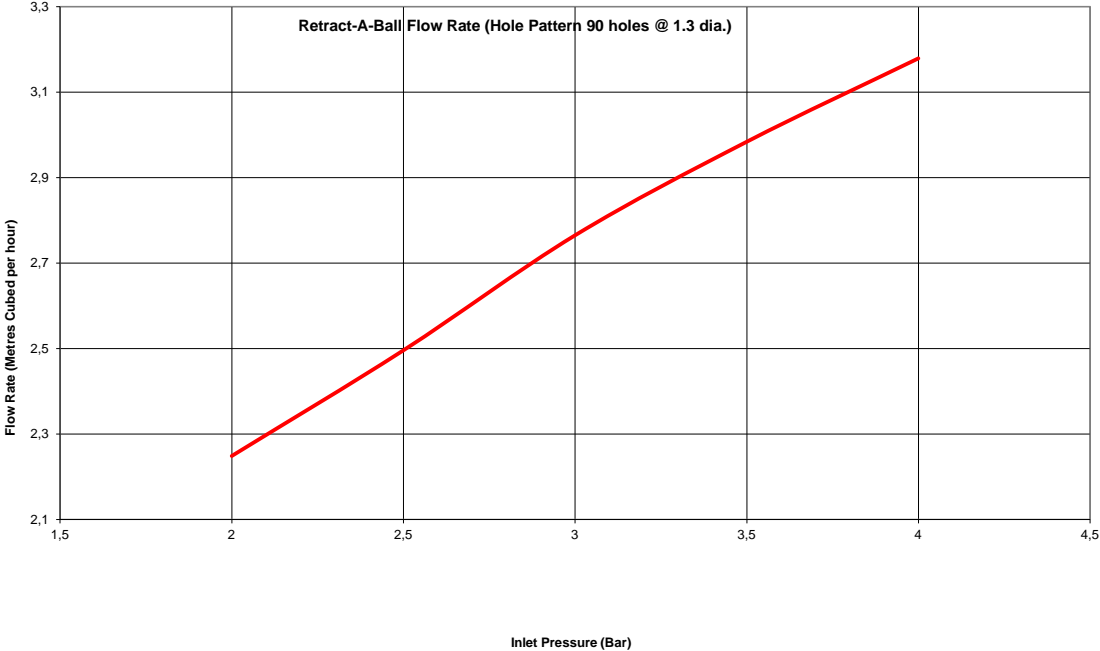

The above Flow Chart shows the typical flow rate through the SSB Retractor fitted with a standard spray ball with 90 holes at 1.3mm dia.

Flow Rates can be changed by different drilling patterns if required.

Installation dimensions and connections

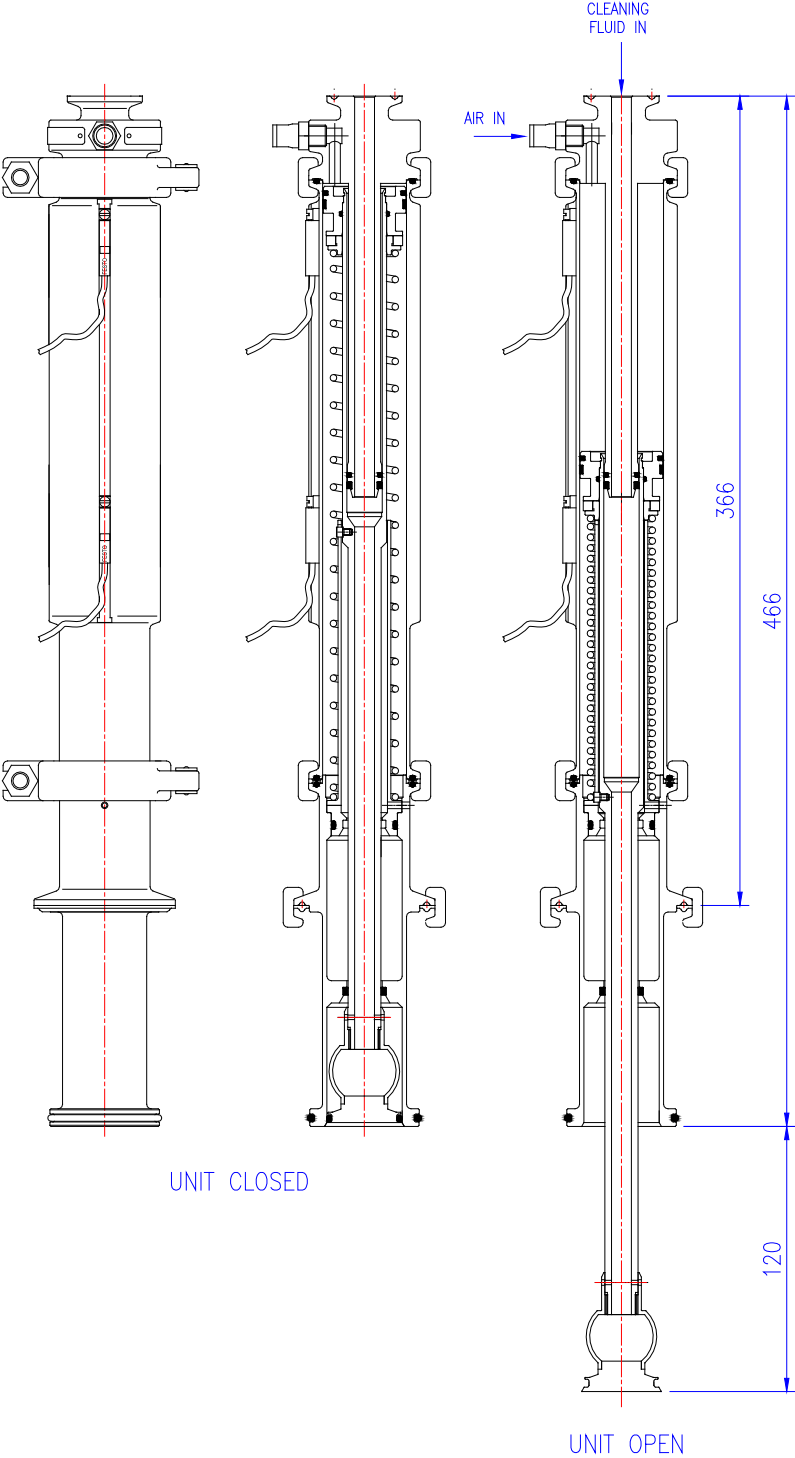

Dimensions

Installation dimensions and connections

NOTES:

1. MATERIALS:	MACHINED COMPONENTS: STAINLESS STEEL - GRADE 316L
2. SEALS:	MACHINED CARBON FILLED PTFE, EPDM or ISOLAST O-RINGS
3. SPRING:	STAINLESS STEEL - GRADE 301S81 (NON-WETTED)
4. BODY JOINTS:	DIN 40 FLANGES. DESIGNED IN ACCORDANCE WITH DIN 32676. (SAFETY CLAMPS)
5. PRESSURES:	CONTROL AIR: 3.5-4 bar (50-58 psi) CLEANING LIQUID: 2-4 bar (29-58 psi)
6. TEMPERATURES:	CLEANING LIQUID: 95°C (203°F) MAX PROCESS: 140°C (284°F)
7. AIR CONNECTION:	1/8" BSP PARALLEL INTERNAL THREAD, FITTED AS STANDARD WITH 6MM OUTSIDE DIA. PUSH FIT CONNECTOR.
8. LIQUID CONNECTION:	DIN 10 FLANGE TO DIN 32676
9. BODY MOUNTING:	DIN 50 FLANGE TO DIN 32676

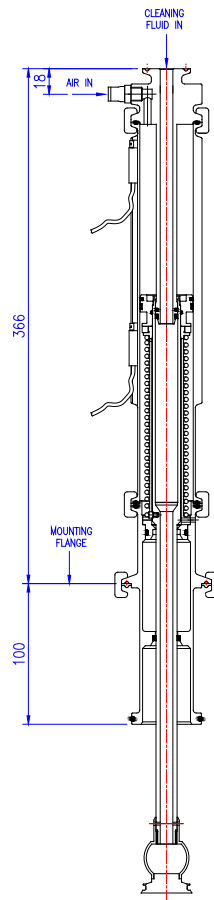

Figure 3 Connections

Installation

The SSB Retractor is mounted to a DIN 50 Ferrule using the DIN 50 gasket and clamp supplied. The unit must be mounted so that it is a minimum for 5° above horizontal. This is important to allow the Home Chamber to drain when cleaning has finished. See Figure 4.

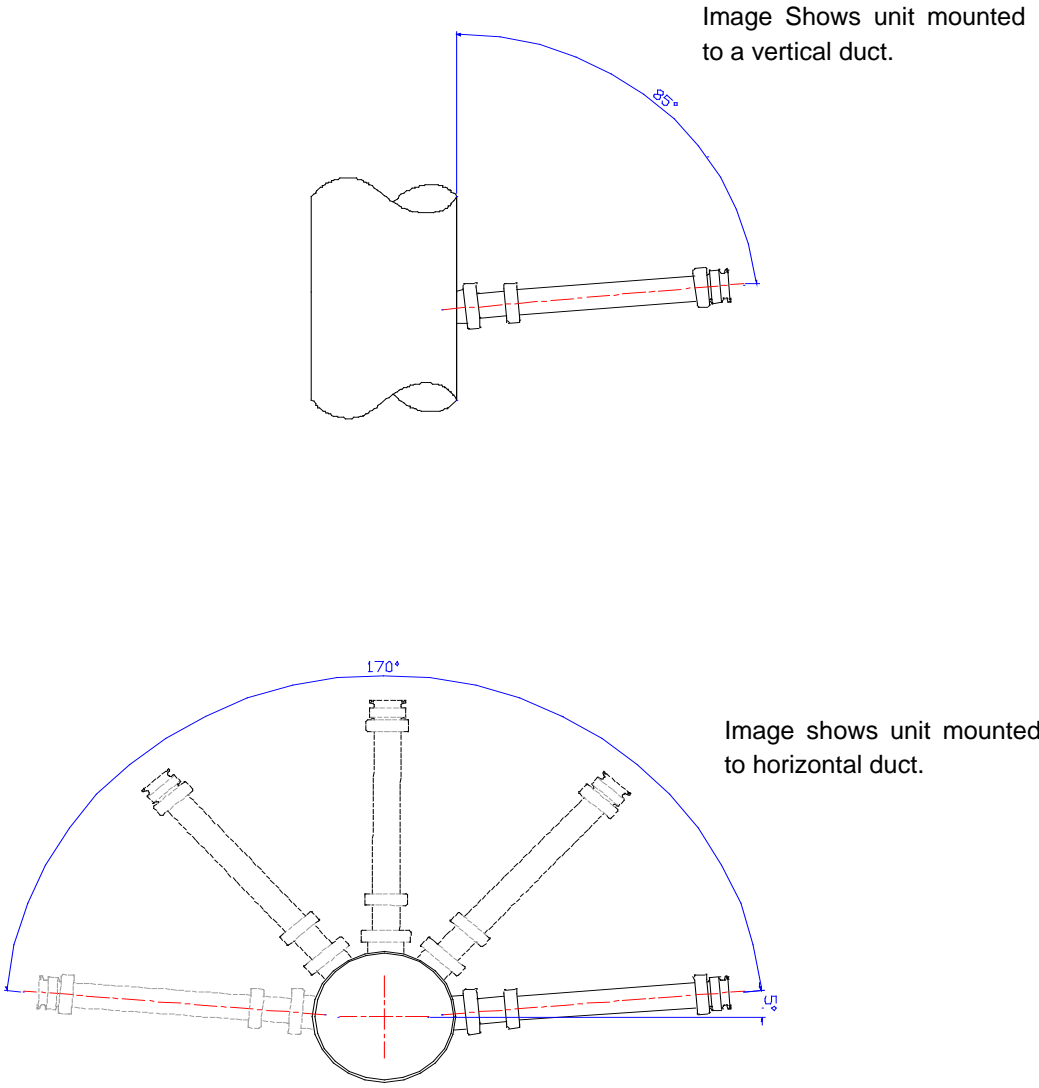

Figure 4 Installation

Installation (continued)

General Safety and Installation Instructions

Note: The machine shall be installed in accordance with national regulations for safety and other relevant regulations and standards.

Precautions shall be made to prevent starting of the cleaning operation, while personnel are inside the tank or otherwise can be hit by jets from the nozzles.

In EU-countries the complete system must fulfil the EU-Machine Directive and depending of application, the EU-Pressure Equipment Directive, the EU-ATEX Directive and other relevant Directives and shall be CE-marked before it is set into operation.

Warning:



If the machine is used in potential explosive atmospheres, tapes or joint sealing compounds which are electrical insulators must not be used on threads or joints, unless an electrical connection is otherwise established to ensure an effective earthing. In addition, connecting pipe work, must be electrically conductive and earthed to the tank structure. The resistance between the nozzles and the tank structure should not exceed 20,000 Ohm. This is essential to avoid the build-up of static electricity on the machine.

For further information see DS/CLC/TR 50404:2003 Safety of Machinery, guidance and recommendations for the avoidance of hazards due to static electricity.

Electrical equipment such as magnetic valves and electric actuators must not be installed in Ex-zones without type approval and marking, corresponding to the EX-class in question.

Installation (continued)

Special Conditions for Safe Use in accordance with the ATEX Certification, Directive 94/9/EC

ATEX Warning: The unit shall be connected to a fully earthed pipeline/duct or tank/vessel.



ATEX Warning: The pipeline/duct shall not exceed a diameter of 3m, and the tank/vessel shall not exceed 100m³.



ATEX Warning: The air operated unit shall only be operated with inert gas or clean air.



ATEX Warning: The unit shall only be purged with inert gas or clean air



In addition to the above mentioned precautions relating to the ATEX guidelines Directive 94/9/EC of March 23 1994, the Safety Precautions on page 15 must be observed.

Installation (continued)

Special Conditions for Safe Use in accordance with the ATEX Certification, Directive 94/9/EC - Continued

ATEX Warning: Do not allow the unit to be operated when process media is in the pipeline or tank.



ATEX Warning: Do not allow the air pressure to exceed 5.5 bar.



ATEX Warning: Do not allow the cleaning media to exceed 4 bar.



ATEX Warning: When an external sensor is fitted to indicate the open or closed position it shall be suitable for the zone in use.





In addition to the above mentioned precautions relating to the ATEX guidelines Directive 94/9/EC of March 23 1994, the Safety Precautions on page 15 must be observed.

Installation (continued)

Special Conditions for Safe Use in accordance with the ATEX Certification, Directive 94/9/EC –(continued)

Temperature

ATEX Warning: 	<u>Atmosphere/surface temperature:</u> In potentially explosive atmospheres, the temperature must not exceed the maximum surface temperature according to the temperature class for the combustible gas or liquid.
---	---

ATEX Warning: 	<u>Steam cleaning:</u> Tanks with capacities greater than 100 m ³ that could contain a flammable atmosphere should not be steam cleaned, as steam issuing from a nozzle could contain charged droplets. Tanks smaller than this may be steam cleaned providing that: the steam nozzles and other metal parts of the system are reliably earthed and grounded to the tank structure.
---	--

Pressure

Avoid hydraulic shocks. Increase pressure gradually. Do not exceed 4 bar inlet pressure. Recommended inlet pressure: 2-4 bar. High pressure in combination with high flow rate will increase consumption of wear parts. High pressure will also reduce the cleaning effect.

ATEX Warning: 	<u>Steam cleaning pressure:</u> If steam cleaning is done through the machine, the steam pressure must not cause the machine to rotate.
---	--

ATEX Warning: 	<u>Draining:</u> If the machine is drained using compressed air, then the compressed air pressure must not cause the machine to rotate.
---	--

Installation (continued)

Orientation

As the Spray Ball on the SSB Retractor is often targeted it is important that the unit is installed in the correct orientation. The Spray balls are keyed to the Home Chamber. The Home Chamber has a roll pin fitted through its side. See Figure 5

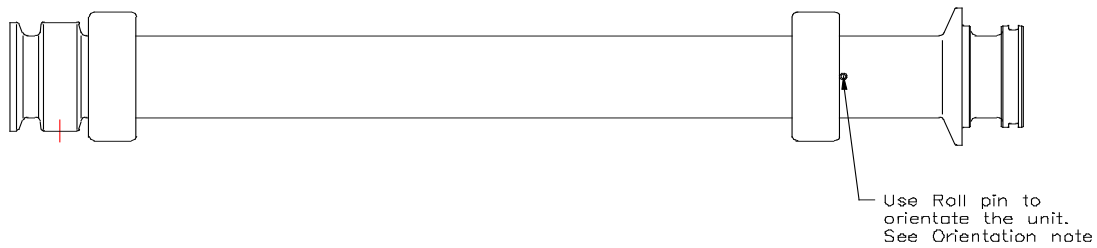

Figure 5 Installation orientation

Once the unit is mounted into the DIN 50 mounting ferrule it should be rotated so that the roll pin points parallel to the duct work to which it is mounted, before the mounting clamp is tightened. This will ensure the correct orientation for the Spray Ball.

In some instances the units may be specially drilled to target certain features or may not be mounted into ductwork. In these instances, the roll pin should again be used to orientate the unit but there will be an instruction enclosed with the unit to advise the direction the pin should point.

It is recommended that a filter with 0.5mm holes is fitted to the supply line.

Before connecting the Cleaning Media Pipe work to the unit it is recommended that the supply lines and valves should be flushed in order to remove any foreign particles.

Air Connection

A supply of dry, clean air is required to operate the SSB Retractor unit. The Inlet Adaptor has a 1/8" BSP FEMALE THREAD which is fitted as standard with a 6mm push fit fitting. The air pressure required is 3.5-4 bar.

Note: IT IS IMPORTANT THAT A NON-RETURN VALVE IS FITTED INTO THE AIR SUPPLY LINE. THIS IS IMPORTANT IN CASE THE AIR SEAL INSIDE THE SSB RETRACTOR SHOULD FAIL. THIS COULD ALLOW THE CLEANING MEDIA TO TRAVEL BACK THROUGH THE AIR LINE.

Installation (continued)

Cleaning Media

The media must be compatible with Stainless Steel 316L, EPDM or ISOLAST and carbon filled PTFE. Normal detergents, moderate solutions of acids and alkaline are acceptable.

After Use Cleaning

After use the units should always be flushed with fresh water. Cleaning media should never be allowed to dry inside the unit due to possible 'salting out' or scaling of the cleaning media.

Warnings

Warning: The unit is operated by compressed air. It is important that the operating pressure is released and isolated before any work is carried out on the unit.



The Body Tube Clamps **must not** be released until the air pressure is released and isolated.

The clamps used on the body of the unit are safety clamps and **cannot** come away from the unit if the clamping nut is accidentally slackened, however great care must be taken.

Fluid and air connections

The unit is supplied with both cleaning media (fluid) at pressure & also air to open the unit. Ensure that both supplies are fitted with a non return valve.

Important recommendation for installation

It is recommended that the media connection to the SSB Retractor is always by means of a flexible, not fixed, coupling/pipe work. This is important to ensure that there is no undue force applied to the unit which can cause internal misalignment and therefore damage.

Installation (continued)

Service and Repair of ATEX Approved Machines

In order to ensure compliance with the ATEX regulations for service and repair in accordance with EN 60079-19, all service and repair of ATEX approved machines should be performed by Alfa Laval Tank Equipment A/S, Ishoej, Denmark.

Warning: ATEX requirements regarding repair of ATEX approved machines according to EN 60079-19.



A tag with the following labelling information must be attached to the machine:

- Repair symbol 
- Alfa Laval logo and address
- Repair number
- Date of repair
- Machine serial number

The tag must be laminated and attached to the machine using a cable tie.

If a customer wishes to carry out service or repair himself, it is the responsibility of the repair shop to ensure that the ATEX requirements are met in any way possible. After performing service or repair, the repair shop thus carries the full responsibility for the ATEX approval of the machine.

Recommended Service Intervals

Inspection every 500 working hours. After 2000 working hours: inspection every 200 hours.

An Inspection consists of: See page 24.

Component parts

List of Parts

Model No.	TE75P233	TE75P233-04	TE75P253	TE75P253-04			
Pos.no.	Ref. No.	Ref. No.	Ref. No.	Ref. No.	Description	QTY	Remarks
1	TE75P526	TE75P526	TE75P526	TE75P526	Body Tube	1	Spare Part
2	TE75P569	TE75P569	TE75P569	TE75P569	Sleeve	1	Spare Part
3	TE75P585	TE75P585	TE75P585	TE75P585	Spray Stem	1	Spare Part
4	TE75P592	TE75P592	TE75P562	TE75P562	Spray ball assembly (drilled)	1	Spare Part
5	TE75P584	TE75P584	TE75P584	TE75P584	Housing DIN 50 x 98mm	1	Spare Part
6	TE75P544	TE75P544	TE75P544	TE75P544	Piston	1	Spare Part
7	TE75P545	TE75P545	TE75P545	TE75P545	Piston Spacer	1	Spare Part
8	TE75P533	TE75P533	TE75P533	TE75P533	Inlet Adaptor	1	Spare Part
9							
10	TE75P572	TE75P572	TE75P572	TE75P572	Spring	1	Spare Part
11			TE75P502	TE75P502	Orientation Screw	1	Spare Part
12	TE75P551	TE75P551	TE75P551	TE75P551	External Circlip	1	Spare Part
13	TE75P552	TE75P552	TE75P552	TE75P552	Spring Pin	1	Spare Part
14	TE75P504	TE75P504	TE75P504	TE75P504	Magnet	1	Spare Part
15	TE75P505	TE75P505	TE75P505	TE75P505	Mounting Clamp DIN 50	1	Spare Part
16	TE75P506	TE75P506	TE75P506	TE75P506	Body Clamp DIN 40	2	Spare Part
17							
18							
19	TE75P538	TE75P508	TE75P538	TE75P508	Home Chamber/Spiqot Seal	1	Wear Part
20	TE75P539	TE75P509	TE75P539	TE75P509	Home Chamber/Stem Seal	1	Wear Part
21	TE75P510	TE75P510	TE75P510	TE75P510	Gasket-Home Chamber	1	Spare Part
22	TE75P573	TE75P573	TE75P573	TE75P573	Solid Gasket Spacer Ring	1	Spare Part
23	TE75P543	TE75P543	TE75P543	TE75P543	Stem Product Seal	1	Wear Part
24	TE75P540	TE75P574	TE75P540	TE75P574	Home Chamber/Sleeve Seal	1	Wear Part
25	TE75P541	TE75P575	TE75P541	TE75P575	Piston/Stem Seal	1	Wear Part
26	TE75P514	TE75P514	TE75P514	TE75P514	Piston Slide Ring	1	Wear Part
27	TE75P515	TE75P515	TE75P515	TE75P515	Piston Seal	1	Wear Part
28	TE75P516	TE75P546	TE75P516	TE75P546	Energising O-Ring	1	Wear Part
29							
30	TE75P517	TE75P517	TE75P517	TE75P517	Adaptor Product Seal	1	Wear Part
31	TE75P518	TE75P518	TE75P518	TE75P518	Adaptor Air Seal	1	Wear Part
32	TE75P519	TE75P549	TE75P519	TE75P549	Energising O-Ring	1	Wear Part
33	TE75P511	TE75P511	TE75P511	TE75P511	O-Ring	3	Wear Part
34	TE75P555	TE75P555	TE75P555	TE75P555	Ball Securing Pin	1	Spare Part
35	TE75P523	TE75P523	TE75P523	TE75P523	Air Connector	1	Spare Part

Component parts (continued)

Parts drawing

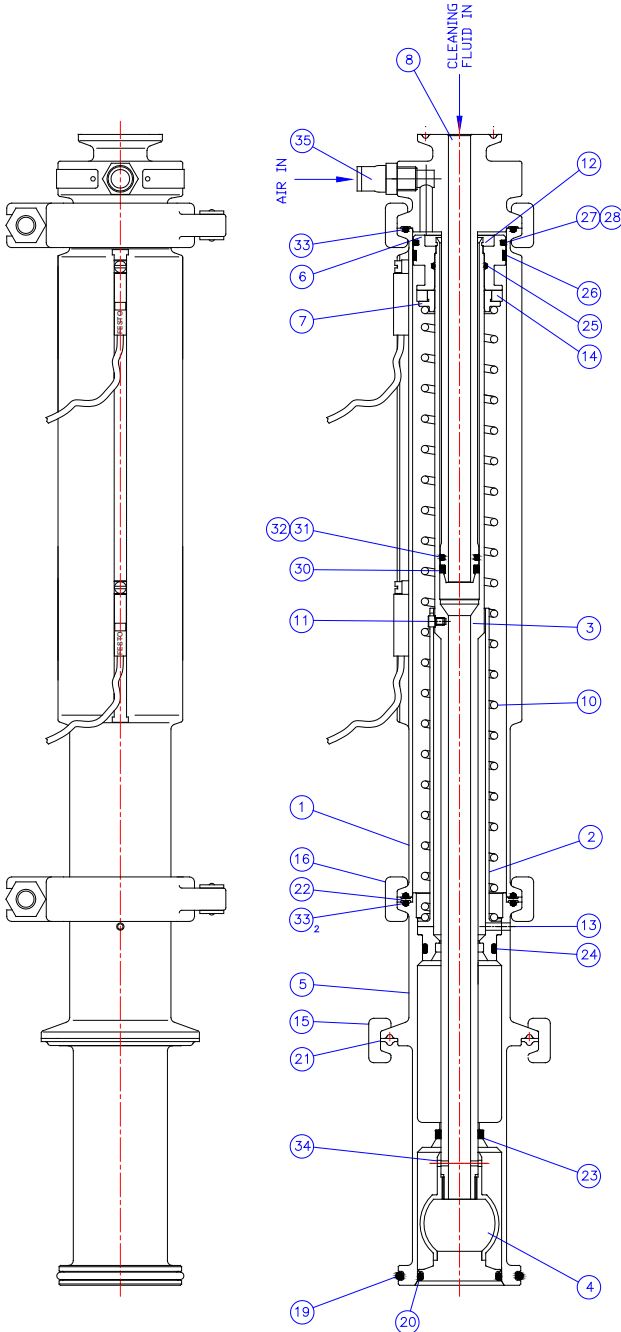

Figure 6 Component Parts

Maintenance

The units are designed to be self cleaning and should require very little or no maintenance between service intervals.

The units are a simple design with only the central telescopic bore being wetted. Performance will be effected by contamination from debris or particles where the CIP system is inadequately filtered or swarf in the system after installation.

Deterioration of the seals will also affect the unit's performance.

It is for this reason that it is recommended that the units are inspected every 500 working hours. After 2000 working hours inspect every 200 working hours.

A spares seal kit is available and does require simple tooling to fit the seals. The part No. for both the seal kit and Seal installation tools are listed in the Spare Parts section of this Manual on page 46.

Dismantling the Unit for Inspection

1. Always release the air pressure to the unit before disconnecting the air supply to the unit.
2. Remove the unit from its mounting so that the work can be carried out in the workshop. To remove the unit release the DIN 50 clamp which retains it to the DIN 50 mounting ferrule (it is the largest clamp on the unit). Carefully draw the unit from the ferrule ensuring that you retain the white PTFE gasket between the mounting ferrule and the head of the unit.
3. Slacken and remove the DIN 40 clamp which secures the Inlet adaptor to the main body tube. See Figure 6 below.



Figure 6 Dismantling

Maintenance (continued)

4. Carefully withdraw the Inlet Adaptor from the Main Body tube. Ensure to be careful & keep the Inlet Adaptor parallel with the Body Tube as it is withdrawn. Two seals will now be visible on the end of the inlet adaptor stem. The larger seal at the end of the inlet adaptor stem is the cleaning media seal and the second smaller seal is an air seal. Both should be examined to assess their condition. See Figure 7.



Figure 7

5. Between the Inlet Adaptor & the Body Tube there is an O-ring (TE75P511)- See Fig 8 above. The O-ring (TE75P511) should be replaced during rebuild.

Maintenance (Continued)

6. Remove the second clamp between the Main Body tube and the Home Chamber and carefully slide the Body Tube from the Piston to reveal the spring. See Figure 9 below.



Figure 9

7. There is a Solid Gasket Spacer Ring & two O-rings between the Home Chamber & the Body Tube.
The Solid Gasket Spacer Ring (TE75P573) should be retained for re-assembly but the two O-rings (TE75P511) should be replaced. See Figure 10 below.



Figure 10

Maintenance (continued)

8. Once the Body Tube is removed the Piston Slide ring will fall away from the Piston. This is normal. See Figure 11.



Figure 11

9. **CAUTION:** To remove the Piston the Circlip inside the recess of the Piston has to be removed. The Spring is under compression at this stage so the Piston must be held downwards as the Circlip is removed to avoid the Piston being ejected by the spring. See Figure 12. When rebuilding the Unit a new Circlip must be used.



Figure 12

Maintenance (continued)

10. The remaining seal visible on the Piston in Figure 13 is the Main Air Seal. This seal is a PTFE ring with an O-Ring underneath to energise the seal.



Figure 13

11. Look inside the piston, there is an O-Ring which seals the piston to the spray stem. This seal should be carefully removed using a small sharp pointer pressed into the O-Ring. The O-Ring must be discarded. See Figure 14



Figure 14

Maintenance (continued)

12. Remove the spring from the remaining body of the SSB Retractor.
13. Remove the Orientation Screw (if fitted) from the Spray Stem as shown in Figure using a 2.5mm Allen key. Retain the screw as it will be required in the re-build.

The Orientation Screw is fitted to ensure the orientation of the spray pattern. If the unit is fitted with a general coverage spray pattern the Orientation Screw may not be fitted.

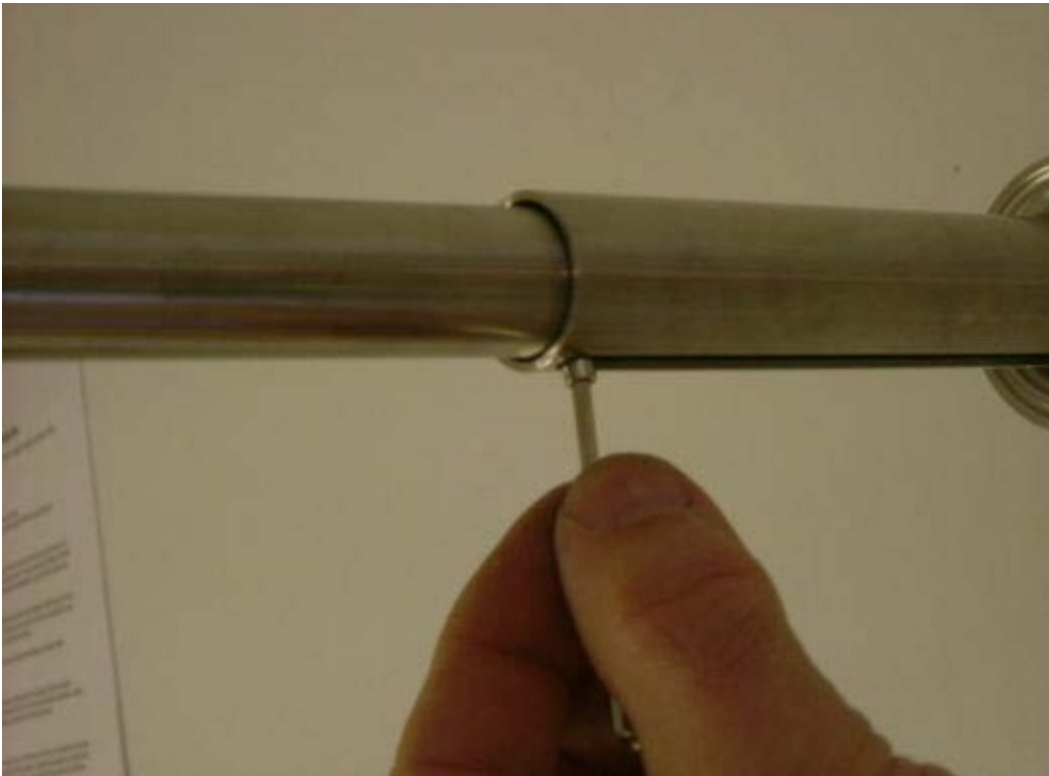

Figure 15

Maintenance (continued)

14. Once the orientation screw is removed, push the spray stem forward to reveal the spray ball. The Sprayball is retained by a 2mm diameter pin which passes through the neck. Straighten the end of the pin with a pair of pliers. See Figure 16.



Figure 16

15. Once the Pin is removed the Sprayball can be unscrewed (anti clockwise) & removed. The Securing Pin must be discarded. See Figure 17



Figure 17

Maintenance (continued)

16. The spray stem can now be drawn out of the main housing. See Figure 18.



Figure 18

17. To remove the sleeve from the main housing the 3mm dia. roll pin should be driven into the housing using a 2.5mm pin punch. (When rebuilding, a new pin must be used.) See Figure 19.



Figure 19

Maintenance (continued)

18. Remove the Sleeve from the main housing to reveal the O-Ring seal. This seal should be carefully removed with a small pair of long nosed pliers & discarded. See Figure 20.



Figure 20

19. The product seal can be seen in the front end of the Home Chamber. This Seal should be carefully removed using a pair of long nosed pliers & discarded. See Fig 21.

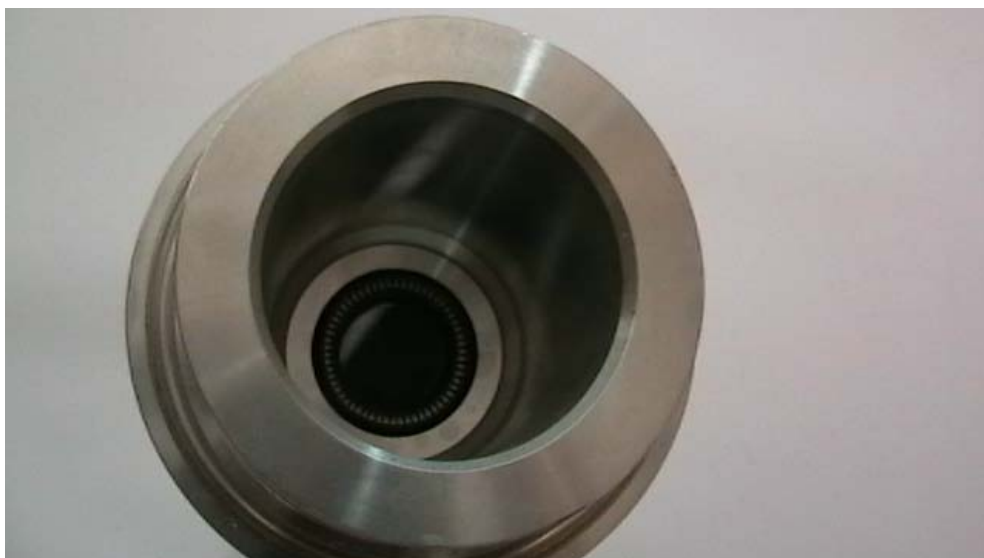

Figure 21

Re-Build & fitment of New Service Repair Kit

The Service Repair Kit for the SSB Retractor unit is-

TE75P288-90 for standard EPDM seals. For units TE75P233 & TE75P253

TE75P288-94 for Perfluorolastomer seals. For units TE75P233-04 & TE75P253-04

Both of the above will also require a Seal Installation Tool Kit to help fit the seals

TE75P299 - Seal Installation Tool Kit.

1. Fitting Adaptor Air Seal parts TE75P519 (EPDM) or TE75P549 (Isolast) & TE75P518
Fit a new Air Seal to the Inlet Adaptor Stem. Firstly fit the Energising O-ring part TE75P519 or TE75P549 into the second groove in the stem. See Figure 22.



Figure 22

- 2 Place the Air Seal Fitment Tool Part TE75P593 over the end of the Inlet Adaptor Stem as shown below in Figure 23

This will allow the Air Seal part No. TE75P518 to be slid over the tool & into position on top of the Energising O-ring. Use the Pusher Tool Part TE75P594 to push seal into positions as shown in fig 24

- | |
|--|
| <ol style="list-style-type: none">1. Energising O-Ring2. Air Seal3. Fitment Tool |
|--|

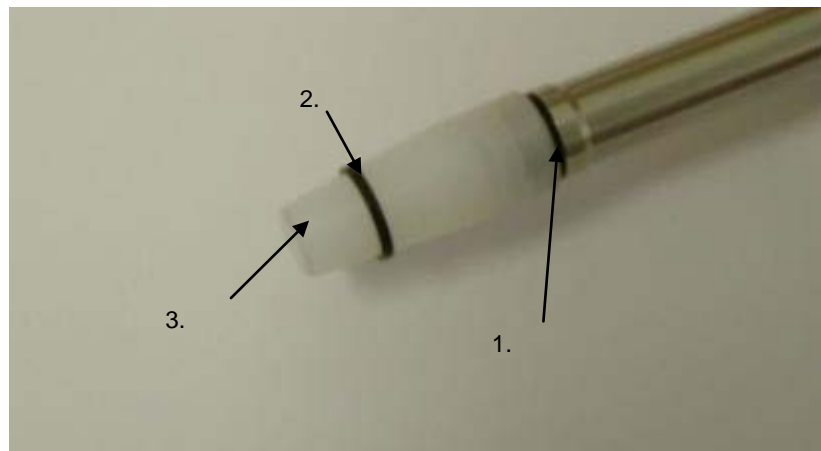

Figure 23

Re-Build & fitment of New Service Repair Kit (continued)



Figure 24

3. This process will stretch the seal & it will appear to be too big. Remove the tools & begin squeezing the seal with fingers to reduce its size. Move around the seal several times with fingers until the seal has returned almost to its original size.

Carefully fit the Air Seal Re-sizing Tool part TE75P595 over the seal & leave for 5 minutes. See Figure 25.



Figure 25

Re-Build & fitment of New Service Repair Kit (continued)

4. Fitting of Adaptor Product Seal Part No. TE75P517

Place the Adaptor Product Seal part TE75P517 onto the end of the stem & carefully push the seal into position. See Figure .



Figure 26

5. Fitting of Stem Product Seal Part No. TE75P543

Place the Stem Product Seal into the front end of the Home Chamber. Position the seal so that one side of the seal enters the seal groove. Carefully work around the seal, pushing it into the groove. Care must be taken not to kink the seal. See Figure 27



Figure 27

Re-Build & fitment of New Service Repair Kit (continued)

6. Fitting of Home Chamber/Sleeve Seal. Part No. TE75P540

Start one side of the O-ring in the O-ring Groove & gently stretch the O-ring into position.
See Figure 28.



Figure 28

7. Fitting the Sleeve into the Home Chamber.

Lightly wet the O-ring on the Sleeve with clean water & offer up to the Home Chamber. Rotate the Sleeve until the 3mm Spring Pin hole aligns with the hole on the Home Chamber.

Push the Sleeve into the Home Chamber & check that the Spring Pin holes align.

Place the Home Chamber on a piece of wood & tap the Spring Pin Part No. TE75P552 fully in using a pin punch.

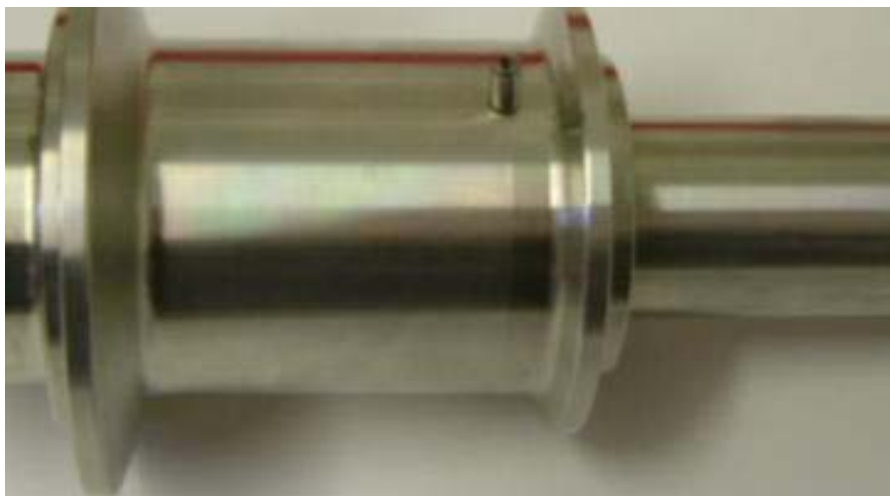

Figure 29

Re-Build & fitment of New Service Repair Kit (continued)

8. Fitting the Spray Stem.

Take the Spray Stem & ensure it is clean. Check down the 16mm bore to ensure that there is no scratching or scoring.

Carefully place the smaller threaded end of the stem through the Product Seal in the Home Chamber. Once aligned, gently tap the end of the stem with the palm of a hand to push the stem through the seal. See Figure 30.



Figure 30

9. Fitting the Spray ball to the Spray Stem.

Ensuring it is clean, gently screw the Spray Ball all the way onto the Spray Stem. Slowly back off the ball on the thread until the small slot in the neck of the ball aligns with the hole in the Spray Stem.

Pass the Ball Securing Pin part No. TE75P555 through the neck of the ball & bend the end with a pair of pliers approximately 10° to prevent it falling out. See figure 31.



Figure 31

Re-Build & fitment of New Service Repair Kit (continued)

10. Fitting the Home Chamber/Stem Seal part No. TE75P538 or TE75P508.

Place the Home Chamber/Stem Seal part No. TE75P538 or TE75P508 into the O-ring groove in the cap of the Spray Ball. See Figure 32.



Figure 32

11. Fitting the Spring.

Push the Spray Stem up so that the Spray Ball enters the Home Chamber.

If the Orientation Screw is required (if a targeted spray pattern is being used) rotate the Spray Stem until the M3 thread is visible through the guide slot in the Sleeve & screw in the Orientation Screw. Nip it up tight but take care not to over tighten as it is a fine thread.

See Figure 33.



Figure 33

Re-Build & fitment of New Service Repair Kit (continued)

12. Pass the Spring over the Spray Stem & Sleeve & ensure that the Spring is seated at the base of the sleeve. See Figure 34.



Figure 34

13. Fitting the Piston/Stem Seal Part No. TE75P541 or TE75P575.
Fit the Piston/Stem Seal into the Internal O-ring groove inside the bore of the Piston.
See Figure 35.



Figure 35

Re-Build & fitment of New Service Repair Kit (continued)

14. Fitting Piston Seal & Energising O-ring Parts TE75P515 & TE75P516 or TE75P546.

Put one side of the O-ring (TE75P516 or TE75P546) into the O-ring groove of the Piston & carefully stretch the O-ring into the groove.

Place one side of the Piston Air Seal Part TE75P515 into the groove on top of the Energising O-ring & carefully run the seal around the Piston so that it drops into the groove.

See Figure 36.

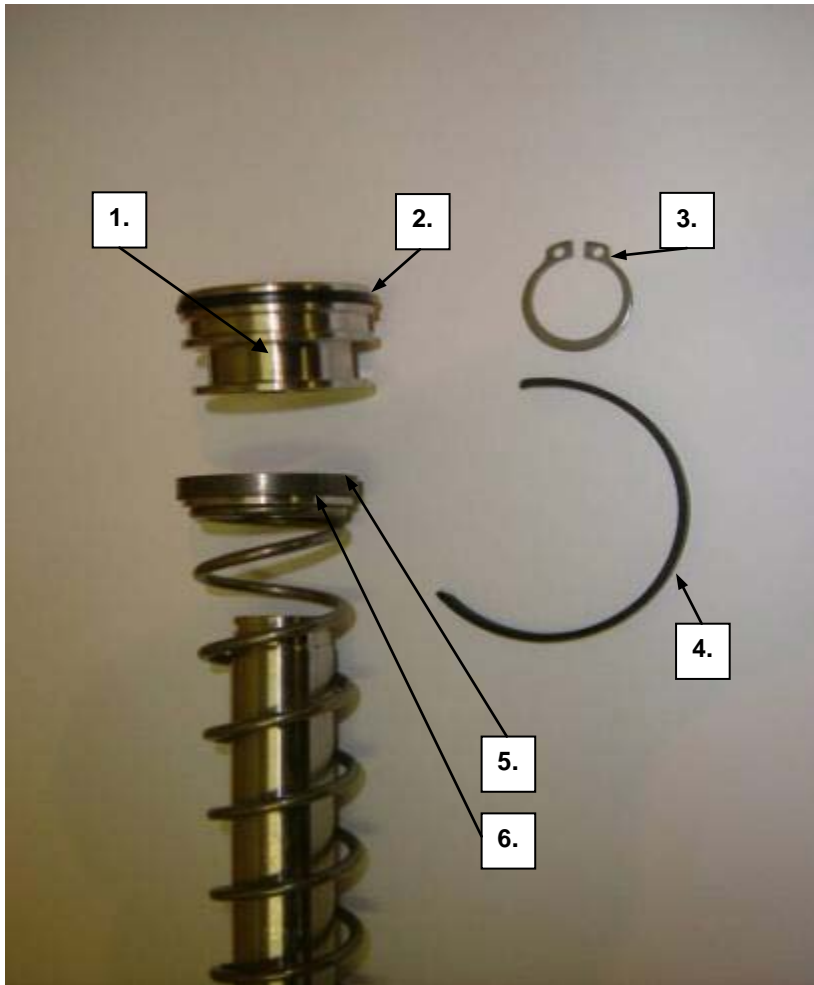

Figure 36

Re-Build & fitment of New Service Repair Kit (continued)

15. Fitting the Piston.

Stand the Retract-A-Ball assembly on the face of the Home Chamber so that the Spring points upwards. Place the Piston Spacer onto the Spring as shown. Place the Ring Magnet onto the Spring Spacer if required. The Magnet will only be required if Proximity Sensors are to be used to indicate open & closed positions. See Figure 37.



1. Piston
2. Piston Air Seal
3. Circlip
4. Piston Slide Ring
5. Ring Magnet
6. Piston Spacer

Figure 37

Re-Build & fitment of New Service Repair Kit (continued)

16. Place the Piston onto the Piston Spacer & push downwards, compressing the Spring so that the Spray Stem enters the Piston. Push down until the Piston is fully seated.

Warning: DO NOT LET GO OF THE PISTON AS THE SPRING IS UNDER COMPRESSION.



Fit a new Circlip Part No. TE75P551 to retain the Piston. See Figure 38.



Figure 38

17. Fitting the Main Body Tube.

While the Unit is still stood vertically, place one of the O-ring Seals (TE75P511) over the Spring & lower into position on the Home Chamber Flange. Follow this with the Solid Gasket Spacer Ring followed by the second O-ring seal (TE75P511). See Fig 39.



Figure 39

Re-Build & fitment of New Service Repair Kit (continued)

18. Ensure the Body Tube is clean & check the internal bore for scratches as this bore forms the air seal with the Piston.

Carefully lower the Body Tube over the Piston & Air Seal, take great care not to damage the Air Seal. Stop once the Seal has just entered the Body Tube & the groove for the Piston Slide Ring is still visible.

Wrap the Piston Slide Ring, part TE75P514 around the Piston groove & carefully lower the Body Tube until it meets the Solid Gasket Spacer ring on the Home Chamber.

Fit the DIN 40 Body Clamp to retain the two parts. See Figure 40.



Figure 40

19. Fitting the Inlet Adaptor.

Place the O-ring (TE75P511) onto the Flange of the Body. See Figure 41 below.



Figure 41

Re-Build & fitment of New Service Repair Kit (continued)

20. Carefully align the end of the Inlet Adaptor Stem in the end of the Spray Stem & push down. Ensure that both seals on the Inlet Adaptor Stem pass in the Spray Stem & do not snag. See Figure 42

Use the Second DIN 40 Body Clamp to retain the Inlet Adaptor.



Figure 42

Re-Build & fitment of New Service Repair Kit (continued)

21. Fitting the Home Chamber Spigot Seal Part No. TE75P538 (EPDM) or TE75P508 (Isolast)

Carefully fit the O-ring in the O-ring groove at the front of the Home Chamber.

See Figure 43.



Figure 43

24. Test the Unit after Re-build.

Lay the Unit on the bench. Connect an air supply to the Air Connector fitted to the Inlet Adaptor. Apply a pressure of 4 Bar to open the SSB Retractor. Release the pressure & ensure the unit closes fully on the return spring.

Extend the unit again with 4 Bar pressure & close off the air supply so that the unit is held in the open position.

Measure the length of the extension with a ruler & leave the unit for half an hour. Re-measure to ensure there has been no movement which would indicate a leak in the air seals.



Figure 44

Standard Service Kit and Tools

Part Number TE75P288-90 for Units TE75P233 & TE75P253

The Standard Service Kit comprises of a full set of replacement seals, a new circlip and new roll pin. All the parts necessary to carry out a service or repair to the seals are included. The Standard Service Kit seal materials are EPDM and carbon filled PTFE.

Standard Service Kit for Units TE75P233 & TE75P253, Part No. TE75P288-90		
Part No.	Description	Qty.
TE75P551	External Circlip	1
TE75P552	Spring Pin	1
TE75P538	Home Chamber/Spigot Seal (EPDM)	1
TE75P539	Home Chamber/Stem Seal (EPDM)	1
TE75P510	Gasket-Home Chamber	1
TE75P543	Stem Product Seal	1
TE75P540	Home Chamber/Sleeve Seal (EPDM)	1
TE75P541	Piston/Stem Seal (EPDM)	1
TE75P514	Piston Slide Ring	1
TE75P515	Piston Seal	1
TE75P516	Energising O-Ring (EPDM)	1
TE75P542	Adaptor/Stem Seal (EPDM)	1
TE75P517	Adaptor Product Seal	1
TE75P518	Adaptor Air Seal	1
TE75P519	Energising O-Ring (EPDM)	1
TE75P511	O-Ring (EPDM)	4
TE75P555	Ball Securing Pin	1

Part Number TE75P288-94 for Units TE75P233-04 & TE75P253-04

However, if the unit was fitted with our 'Special Trim' seals required due to aggressive product or cleaning media, the service kit required is part number TE75P288-94. The seal materials are FFKM (Perfluoroclastomer) and carbon filled PTFE.

**Standard Service Kit for Units TE75P233-04 & TE75P253-04 “Special Trim”
Part No. TE75P288-94**

Part No.	Description	Qty.
TE75P551	External Circlip	1
TE75P552	Spring Pin	1
TE75P508	Home Chamber/Spigot Seal (Isolast)	1
TE75P509	Home Chamber/Stem Seal (Isolast)	1
TE75P510	Gasket-Home Chamber	1
TE75P543	Stem Product Seal	1
TE75P574	Home Chamber/Sleeve Seal (Isolast)	1
TE75P575	Piston/Stem Seal (Isolast)	1
TE75P514	Piston Slide Ring	1
TE75P515	Piston Seal	1
TE75P546	Energising O-Ring (Isolast)	1
TE75P576	Adaptor/Stem Seal (Isolast)	1
TE75P517	Adaptor Product Seal	1
TE75P518	Adaptor Air Seal	1
TE75P549	Energising O-Ring (Isolast)	1
TE75P511	O-Ring (EPDM)	4
TE75P555	Ball Securing Pin	1

Tools, Part Number TE75P299

A number of simple installation tools are required to fit the new seals. All the required tools are included in this kit.

Tools, Article no. TE75P299

Part No.	Description	Qty.
TE75P593	Air Seal Fitment Tool	1
TE75P594	Pusher Tool	1
TE75P595	Air Seal Re-sizing Tool	1

How to order Spare Parts and Claim Procedure

How to Order Spare Parts

On the Cross Sectional Drawing as well as on all instruction drawings, the individual parts have a pos. no., which is the same on all drawings. From the pos. no. the part is easily identified in the Reference List of Parts, page 22.

Individual parts should always be ordered from the Reference Lists of Parts, page 22. Ref. no. and description should be clearly stated.

Please also quote the type of machine and serial no. This will help us to help you. The type and serial nos. are stamped on the Body of the tank cleaning machine.

Claim Procedure

In case of failure that needs assistance from Alfa Laval Tank Equipment A/S, it is essential for our evaluation that the problem as well as the working conditions of the machine are described as detailed as possible.

For description of the working conditions, fill in copy of Claim Report - Working Conditions, which you will find at the back of this manual.

How to contact Alfa Laval Tank Equipment A/S

For further information please feel free to contact:

Alfa Laval Tank Equipment A/S
Baldershoej 19
P.O. Box 1149
2635 Ishoej
Denmark

Phone no.: +45 43 55 86 00
Fax no.: +45 43 55 86 01
www.alfalaval.com

Contact details for all countries are continually updated on our websites.

EC Declaration of Conformity

We

Manufacturer: Alfa Laval Tank Equipment A/S
Address: Baldershøj 19, DK-2635 Ishøj
Phone: +45 43 55 86 00
Fax: +45 43 55 86 01
E-mail: tankequipment.info@alfalaval.com

herewith declare that the below mentioned product:

SSB Retractor Stroke 120 Air-to-Spring 98 mm mounting

TE75P233 ATEX article index no. -70 or -80	TE75P233-04 ATEX article index no. -74 or -84	TE75P253 ATEX article index no. -70 or -80	TE75P253-04 ATEX article index no. -74 or -84
---	--	---	--

is in conformity with the provisions of:

- The Machinery Directive 2006/42/EC, Annex II, Paragraph 1, Part A
- The Equipment explosive atmospheres (ATEX) Directive 94/9/EC.
- The Pressure Directive 97/23/EC
- FDA 21CFR§177

Harmonised European Standards:

The machine is manufactured in accordance with the relevant clauses of the following standards:

The Machinery Directive:

DS/EN ISO 12100-1, DS/EN ISO 12100-2, EN 1672-2

The pressure directive:

According to its own volume and the rated pressure range the product is regarded an Article 3, par. 3 Equipment.



EC Declaration of Conformity

The ATEX-Directive:

DS/EN 1127-1, DS/EN 13463-1, DS/EN 13463-5
DS/EN ISO/IEC 80079-34, Annex A, paragraph A.5.3 Rotating machines

ATEX Certification:

EC Type Examination Certificate no. Baseefa11ATEX0231X

Marking:  II 1GD c T(Variable) Tamb -10°C to +140°C
 II 1GD c T(Variable) Tamb -10°C to +180°C

Note: (T)ambient rating: -10°C to +140°C when fitted with EPDM seals
-10°C to +180°C when fitted with Perfluorolastomer seals.

Baseefa (2001) Ltd., Notified Body number 1180. Rockhead Business Park, Staden Lane, Buxton, Derbyshire SK17 9RZ, United Kingdom

Place: Ishoej, Denmark
Date: January 16, 2012

Place: Ishoej, Denmark
Date: January 16, 2012

Signature: 

Signature: 

Name and title:

Henrik Falster Hansen
R&D Manager

Name and title:

Denniz Høxbroe
ATEX responsible engineer

ATEX-Special Conditions for safe use

ATEX CERTIFICATION

 II 1GD c T(Variable) Tamb -10°C to +140°C

 II 1GD c T(Variable) Tamb -10°C to +180°C

BASEEFA CUSTOMER REFERENCE No. 5322

PROJECT FILE No. 11/0682

Special Condition for Safe Use

1. The Unit shall be connected to a fully earthed pipeline/duct or tank/vessel.
2. The pipeline/duct shall not exceed a diameter of 3m, and the tank/vessel shall not exceed 100m³.
3. The air operated unit shall only be operated with inert gas or clean air.
4. The unit shall only be purge using inert gas or clean air.
5. Do not allow the unit to be operated when process media is in the pipeline or tank.
6. Do not allow the air pressure to exceed 5.5 Bar.
7. Do not allow the cleaning media to exceed 4 Bar.
8. When an external sensor is fitted to indicate the open or closed position it shall be suitable for the zone of use.

This product fully complies to ATEX category 1 as long as the 8 special conditions above are adhered to.

Please read the above conditions prior to installation & ensure that all conditions are met.

Explanation of T (temperature) rating.

The ATEX classification

 II 1GD c T(Variable) Tamb -10°C to +140°C when fitted with EPDM seals

 II 1GD c T(Variable) Tamb -10°C to +180°C when fitted with Perfluorolastomer seals

Shows the temperature rating as T(Variable).

This is because the SSB Retractor max temperature that it will reach will be dependent upon the temperature of the production process or the temperature of the CIP media which passes through it.

How to contact Alfa Laval

Contact details for all countries are continually updated on our website.

Please visit www.alfalaval.com to access the information directly.

© Alfa Laval Corporate AB

This document and its contents is owned by Alfa Laval Corporate AB and protected by laws governing intellectual property and thereto related rights. It is the responsibility of the user of this document to comply with all applicable intellectual property laws. Without limiting any rights related to this document, no part of this document may be copied, reproduced or transmitted in any form or by any means (electronic, mechanical, photocopying, recording, or otherwise), or for any purpose, without the expressed permission of Alfa Laval Corporate AB. Alfa Laval Corporate AB will enforce its rights related to this document to the fullest extent of the law, including the seeking of criminal prosecution.