

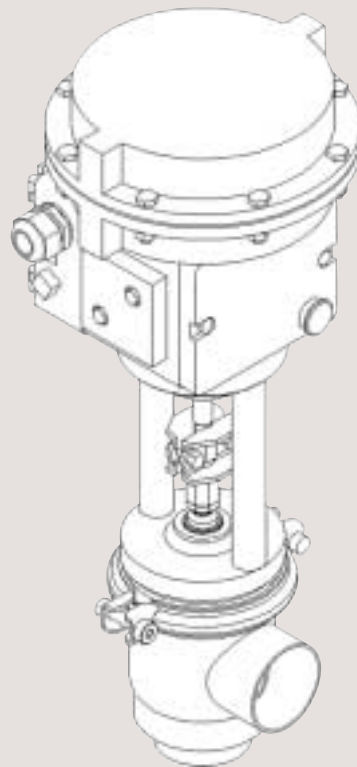

Instruction Manual

SPC-2 Sanitary Electro-Pneumatic Modulating Valve



IM70736-EN4

2010-04

Original Instructions

Declaration of Conformity

The designating company

Alfa Laval

Company Name

6000 Kolding

Address

+45 79 32 22 00

Phone No.

hereby declare that

**SANITARY ELECTRO-PNEUMATIC
MODULATING VALVE**

Denomination

SPC-2

Type

Year

h Z T` _Wc^ Zj h ZY eV W]] h Z_X UZVTegVd+

f > RTYZ_Vg 5ZVTegV #! !' Z/#z64

Bjarne Søndergaard

Name

> R_RXVd Ac Uf Te4V_eVdL
4` ^ aRTe9VRe6i TYR_XVd . 7]f ZU 9R_UJZ_X

Title

Alfa Laval

Company

B. Søndergaard

Signature

Designation



Table of contents

This manual is divided up into main sections. - See below.

Safety

1. Important information	2
2. Warning signs	2
3. Safety precautions	3

Installation

1. Unpacking/Delivery	4
2. Installation	5

Operation

1. General operation	6
2. Fault finding	6
3. Adjustment of the valve	7
4. Adjustment in case of 20 mm stroke deviation	8
5. Changing of the actuator function	9
6. Recommended cleaning	10

Maintenance

1. General maintenance	11
2. Dismantling	12
3. Reassembly	13

Technical data

1. Technical data	14
2. Selection/Pressure drop - capacity diagram	15

Drawings/Parts list

1. Parts list	16+18
2. Exploded drawing	17
3. Drawings	19

Safety

Unsafe practices and other important information are emphasized in this manual.

Warnings are emphasized by means of special signs.

1. Important information

Always read the manual before using the valve!

2

- WARNING!** : Indicates that special procedures **must** be followed to avoid severe personal injury.
- CAUTION!** : Indicates that special procedures **must** be followed to avoid damage to the valve.
- NOTE!** : Indicates important informations to simplify practices or to make them clearer.

2. Warning signs



: General warning.



: Caustic agents.

Transportation:

Always secure that compressed air is released

Always secure that all connections is disconnected before attempt to remove the valve from the installation

Always drain liquid out of valves before transportation

Always used predesigned lifting points if defined

Always secure sufficient fixing of the valve during transportation - if special designed packaging material is available it must be used

All warnings in the manual are summarized on this page.

Pay special attention to the instructions below so that severe personal injury and/or damage to the valve are avoided.

3. Safety precautions

Installation:



- : - **Always** read the technical data thoroughly (See page 14).
- **Always** release compressed air after use.

Operation:



- : - **Always** read the technical data thoroughly (See page 14).
- **Always** release compressed air after use.
- **Always** disconnect the electrical connection before dismantling.



- : - **Never** touch the valve or the pipelines when processing hot liquids or when sterilizing.
- **Never** dismantle the valve with valve and pipelines under pressure.



- : **Always** handle lye and acid with great care.

Maintenance:



- : - **Always** read the technical data thoroughly (See page 14).
- **Always** release compressed air after use.
- **Always** disconnect the electrical connection before service.



- : - **Never** service the valve when it is hot.
- **Never** service the valve with valve and pipelines under pressure.

Recycling information.

• Unpacking

- Packing material consists of wood, plastics, cardboard boxes and in some cases metal straps.
- Wood and cardboard boxes can be reused, recycled or used for energy recovery.
- Plastics should be recycled or burnt at a licensed waste incineration plant.
- Metal straps should be sent for material recycling.

• Maintenance

- During maintenance oil and wear parts in the machine are replaced.
- All metal parts should be sent for material recycling.
- Worn out or defective electronic parts should be sent to a licensed handler for material recycling.
- Oil and all non metal wear parts must be taken care of in agreement with local regulations.

• Scrapping

- At end of use, the equipment shall be recycled according to relevant, local regulations. Beside the equipment itself, any hazardous residues from the process liquid must be considered and dealt with in a proper manner. When in doubt, or in the absence of local regulations, please contact the local Alfa Laval sales company.

Installation

The instruction manual is a part of the delivery.

Study the instructions carefully.

1. Unpacking/Delivery

1

NOTE!

We cannot be held responsible for incorrect unpacking.

2

Check the delivery for:

1. Complete valve.
2. Delivery note.
3. Instruction manual.

3

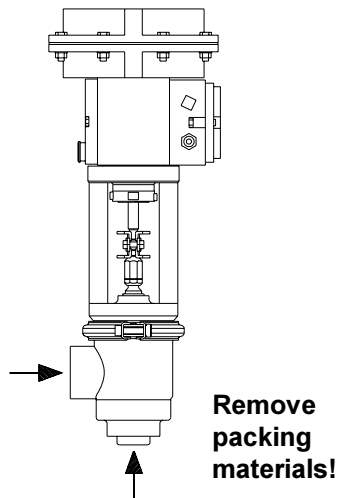

Remove possible packing materials from the valve ports.

4

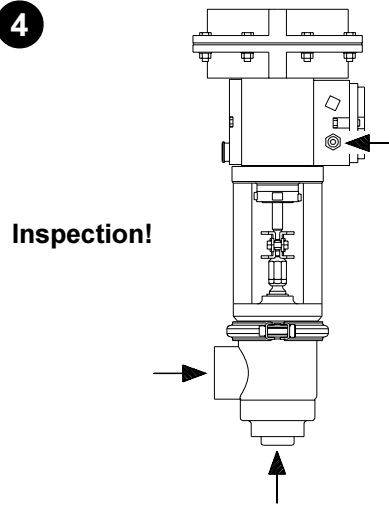

Inspect the valve for visible transport damages.

5

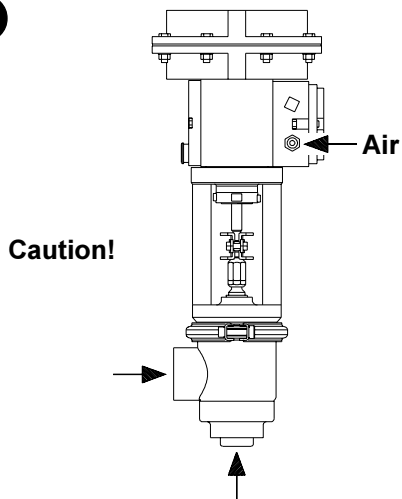

Avoid damaging the air connection, the electrical connection and the valve ports.

Study the instructions carefully and pay special attention to the warnings!

The valve has welding ends as standard but can also be supplied with fittings.

2. Installation

1



- **Always** read the technical data thoroughly (See page 14).
- **Always** release compressed air after use.

CAUTION!

- Always let the valve be electrically connected by authorized personnel.
- The I/P-converter of the actuator is adjusted before delivery and must **never** be opened.

NOTE!

We cannot be held responsible for incorrect installation.

3

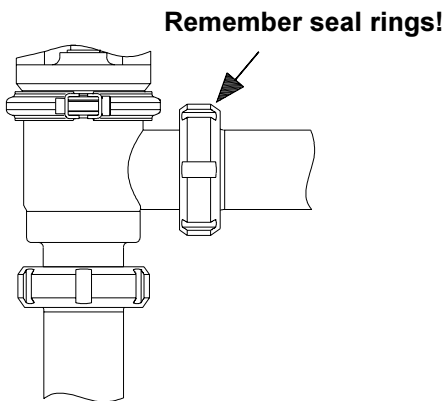

Fittings:

Ensure that the connections are tight.

5

Dimension	A (mm)
38mm/DN40	100
51mm/DN50	105
63.5mm/DN65	130
76mm/DN80	145
101.6mm/DN100	180

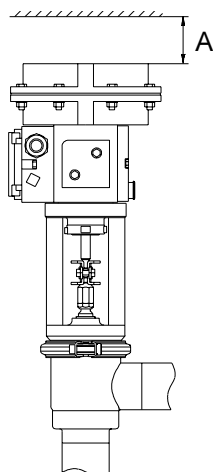

Welding into a manifold:

Maintain the minimum clearance (A) so that the actuator can be removed.

2

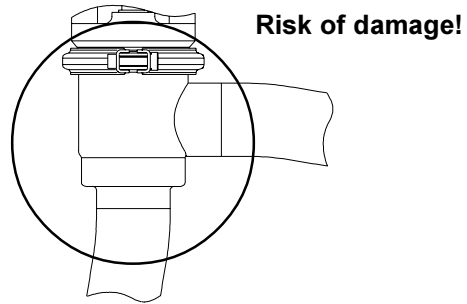

Avoid stressing the valve.

Pay special attention to:

- Vibrations.
- Thermal expansion of the tubes.
- Excessive welding.
- Overloading of the pipelines.

4

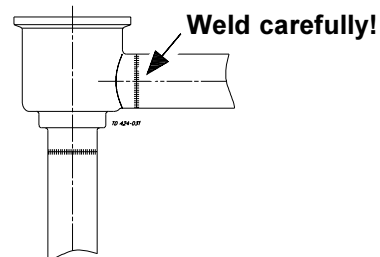

Welding:

1. Remove the internal valve parts in accordance with instruction 1 on page 12.
2. Weld the valve into the pipelines.
3. Assemble the valve in accordance with instruction 5 on page 13.

6

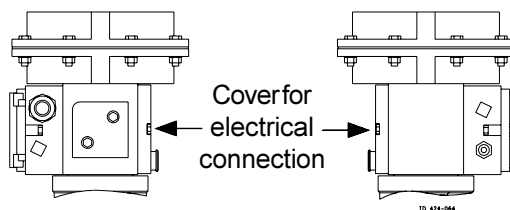

Electrical connection:

1. Remove the black cover from the actuator.
2. Fit the cable through the cable gland and connect it to the terminal strip. **Ensure correct polarity (11 = +, 12 = -)!**
3. Tighten the cable gland and refit the cover.

Operation

The valve is adjusted and tested before delivery. The adjustment instructions on page 7-8 are only to be used if further adjustment is required!

Study the instructions carefully and pay special attention to the warnings! Pay attention to possible faults.

6

1. General operation

1



- **Always** read the technical data thoroughly (See page 14).
- **Always** release compressed air after use.
- **Always** disconnect the electrical connection before dismantling.

CAUTION!

The I/P-converter of the actuator is adjusted before delivery and must **never** be opened.

NOTE!

We cannot be held responsible for incorrect installation.

2

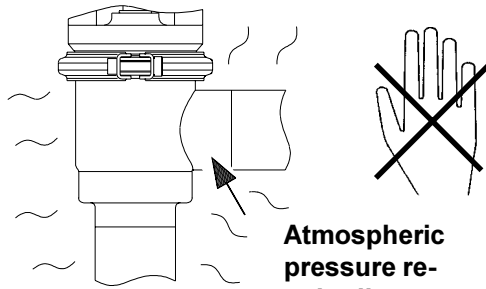

Atmospheric pressure required!



- **Never** touch the valve or the pipelines when processing hot liquids or when sterilizing.
- **Never** dismantle the valve with valve and pipelines under pressure.

2. Fault finding

NOTE!

- Study the adjustment instructions carefully before adjusting the valve. - See page 7-8!
- Study the maintenance instructions carefully before replacing worn parts. - See page 11!

Problem	Cause/result	Repair
- Leaking lip seal at the piston	- Worn lip seal	- Replace the lip seal
- Leaking seal at the valve body	- Incorrect rubber grade	- Replace with a seal of a different rubber grade
Deviation in the flow regulation	Worn valve plug	Replace the plug and adjust (See page 7)
Deviation in the flow regulation	Mechanical parts have come loose (vibrations)	Tighten and adjust (See page 7)
Actuator does not regulate	Actuator errors	Return the actuator to the supplier

The valve is adjusted and tested before delivery. The adjustment instructions on this page are only to be used if further adjustment is required!

Study the instructions carefully. Calibrate with care.

3. Adjustment of the valve

1

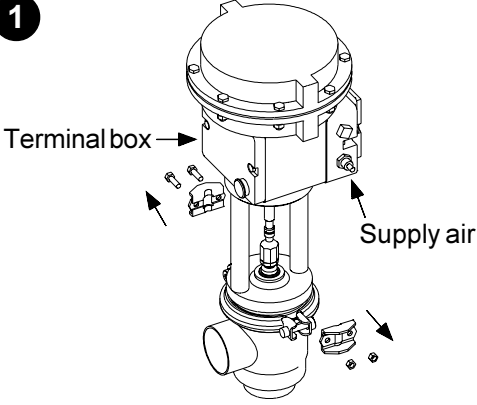

Terminal box → Supply air

- Loosen and remove clamp fitting (9).
- Remove the cover from the terminal box.
- Fit air fittings in entry 9 on the actuator.
- Supply compressed air (4 bar) to the air fittings.

TD 424-068

2

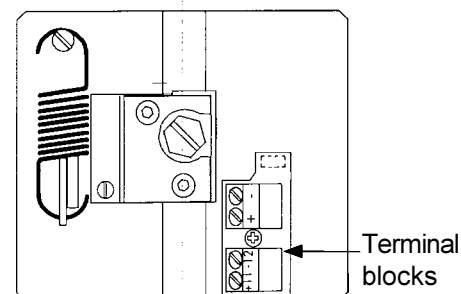

Terminal blocks

- Set the highest signal (20 mA), + on terminal block 11 and - on terminal block 12.

NOTE!
For NC valve the signal must be 4 mA.

- Make sure that valve plug (2) is pressed against the valve seat.

3

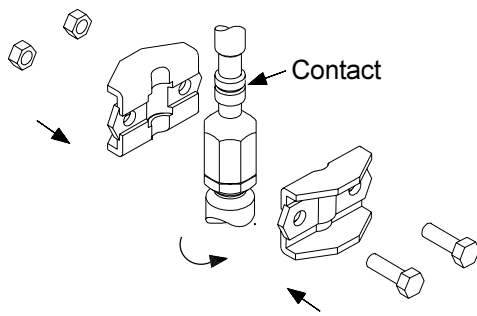

Contact

- Adjust valve plug adjuster (7) so that it contacts the actuator piston rod. (Give 1/4 extra turn to give preforce on the plug).
- Tighten lock nut (8) using a spanner.
- Fit and tighten clamp fitting (9) to connect the actuator piston rod with valve plug (2).

TD 424-069

4

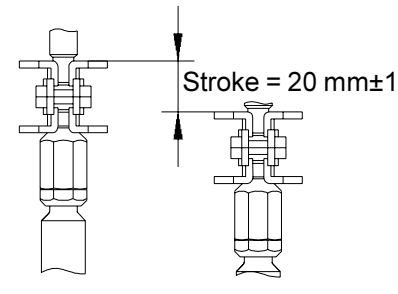

Stroke = 20 mm ± 1

TD 424-067

Check the stroke by changing the signal from 20 to 4 mA (NO) (Opposite if NC).
Stroke = 20 mm ± 1.

NOTE!
In case of deviation from 20 mm stroke, see page 8.

5

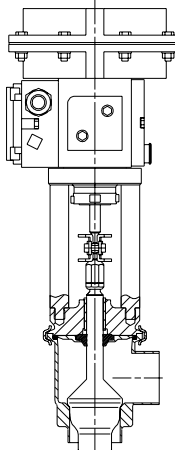

TD 424-068

Move valve plug (2) up and down several times and check that the valve plug is still in closed position. If not, readjust.

Operation

8

The valve is adjusted and tested before delivery.
The adjustment instructions on this page are only to be used if further adjustment is required!

Study the instructions carefully.
Adjust with care.
NO = Normally open.
NC = Normally closed.

4. Adjustment in case of 20 mm stroke deviation

1

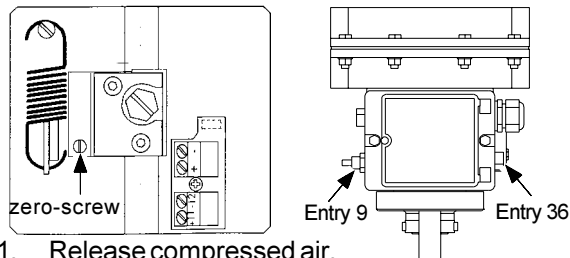

1. Release compressed air.
2. Remove clamp fitting (9).
3. Remove the terminal box cover.
4. Supply compressed air (4 bar) to entry 9.
5. Set the lowest signal (4mA), + on terminal block 11 and - on terminal block 12 (20mA for NC valve).
6. Adjust with the zero-screw (clockwise) to ensure max. open position.

2

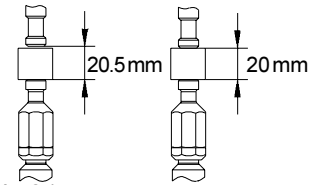

NOTE!

Maximum stroke is 21 mm.

1. Place a 20 mm block between the actuator piston rod and the valve plug (2).
2. Adjust valve plug adjuster (7) to a position with a distance of 0.5 mm + the 20 mm block between the actuator piston rod and the valve plug (use a gauge blade to determine the 0.5 mm).
3. Adjust with the zero-screw (counterclockwise) until the actuator piston rod contacts the 20 mm block and can be moved slightly. Turn the zero-screw 1/2 round (counterclockwise) to give preforce on the valve plug.

3

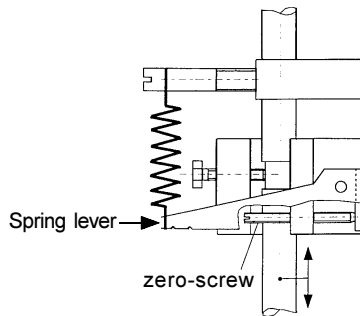

CAUTION!

Do not touch the zero-screw.

1. Pull the spring lever gently down to release the 20 mm block.
2. Remove the 20 mm block.

4

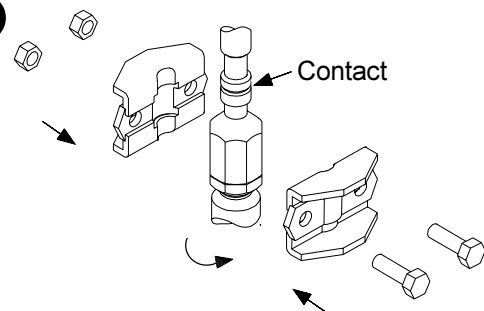

1. Set the highest signal (20 mA), + on the terminal block 11 and - on the terminal block 12 (4mA for NC valve) (the actuator piston rod contacts valve plug (2) and gives preforce).
2. Fit and tighten clamp fitting (9) to connect the actuator piston rod with the valve plug.
3. Check that the stroke is 20 mm.

The actuator function can be changed from NO to NC or vice versa.
 NO = Normally open.
 NC = Normally closed.

Study the instructions carefully.

5. Changing of the actuator function

1 NOTE!

Check the actuator type before changing the actuator function.

1. Separate the actuator from the valve according to instructions 1-3 on page 12.
2. Unscrew and remove the hexagonal nuts and bolts. The 2 long bolts must be unscrewed and removed last to slowly decompress the springs.
3. Lift off diaphragm case (a) and remove springs (b).
4. Pull out actuator piston rod (c), diaphragm plate (d), plate (e) and diaphragm (f) from yoke (g).
5. Unthread nut (h) while counterholding nut (i). The nut (i) must not be removed on the actuator piston rod. Should the nut be removed, adjust the nut so that the dimension 187.5 mm is assured.
Pay special attention to the warnings!

2

1. Turn over diaphragm plate (d), plate (e) and diaphragm (f) fit them on actuator piston rod (c) and thread on nut (h) again.
2. Fit the actuator piston rod with diaphragm plate, plate and diaphragm in yoke (g).
3. Fit springs (b) and diaphragm case (a).
4. Fit and tighten bolts and hexagonal nuts. Fit and tighten the 2 long bolts first to slowly compress the springs.
5. Connect the actuator piston rod with the valve plug according to instructions 4-5 on page 13.
Pay special attention to the warnings!
6. Turn the switch over plate.
7. Adjust the valve as described on page 7.

3

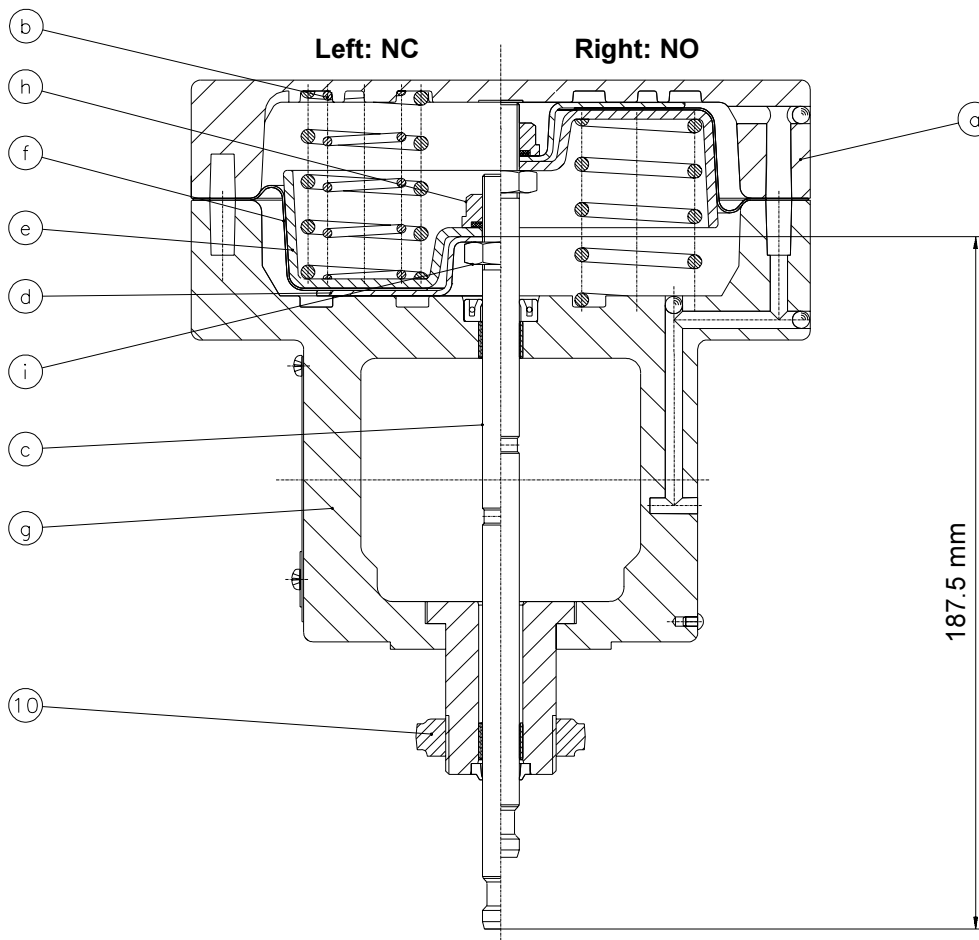

Operation

10

The valve is designed for cleaning in place (CIP).
CIP = Cleaning In Place.

Study the instructions carefully and pay special attention to the warnings!

NaOH = Caustic Soda.

HNO₃ = Nitric acid.

6. Recommended cleaning

1

Caustic danger!



Always use rubber gloves!



Always use protective goggles!



Always handle lye and acid with great care.

3

Examples of cleaning agents:

Use clean water, free from chlorides.

1. 1% by weight NaOH at 70°C.

1 kg NaOH	+	100 l water	= Cleaning agent.
-----------	---	-------------	-------------------

2,2 l 33% NaOH	+	100 l water	= Cleaning agent.
----------------	---	-------------	-------------------

2. 0.5% by weight HNO₃ at 70°C.

0,7 l 53% HNO ₃	+	100 l water	= Cleaning agent.
----------------------------	---	-------------	-------------------

5

Always rinse!

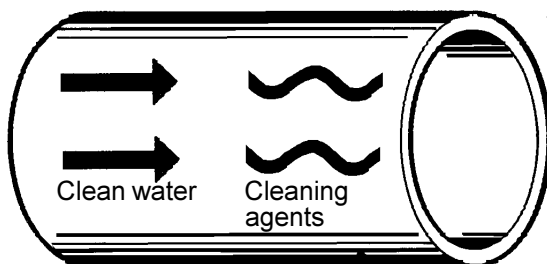

Always rinse well with clean water after the cleaning.

2

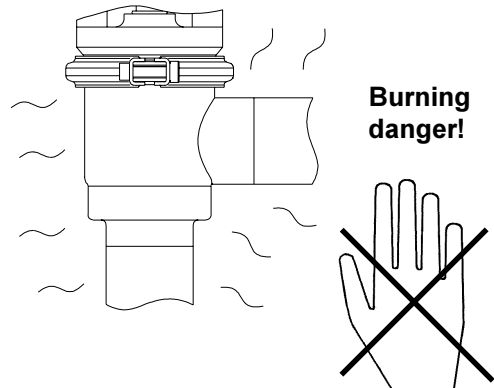

Burning danger!



Never touch the valve or the pipelines when sterilizing.

4

1. Avoid excessive concentration of the cleaning agent

⇒ Dose gradually!

2. Adjust the cleaning flow to the process

⇒ Milk sterilization/viscous liquids

⇒ Increase the cleaning flow!

6

NOTE!

The cleaning agents must be stored/disposed of in accordance with current rules/directives.

Maintain the valve carefully.
Study the instructions carefully and pay special attention to the warnings!

Always keep spare lip seals and guide rings in stock.

1. General maintenance

1



- **Always** read the technical data thoroughly (See page 14).
- **Always** release compressed air after use.
- **Always** disconnect the electrical connection before service.

CAUTION!

The I/P-converter of the actuator is adjusted before delivery and must **never** be opened.

NOTE!

All scrap must be stored/disposed of in accordance with current rules/directives.

2

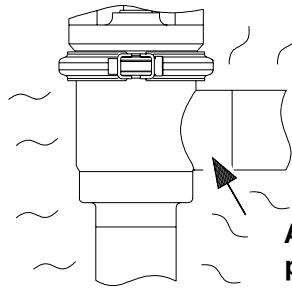

Burning danger!



Atmospheric pressure required!



- **Never** service the valve when it is hot.
- **Never** service the valve with valve and pipelines under pressure.

Ordering spare parts

- Contact the Sales Department.
- Order from the Spare Parts List.

Recommended spare parts: Service kits (see Spare Parts List).

	Valve lip seal	Valve bearing
Preventive maintenance	Replace after 12 months	Replace when replacing the lip seal
Maintenance after leakage (leakage normally starts slowly)	Replace by the end of the day	Replace when replacing the lip seal
Adjusted maintenance	<ul style="list-style-type: none"> - Regular inspection for leakage and smooth operation - Keep a record of the valve - Use the statistics for planning of inspections Replace after leakage	Replace when replacing the lip seal
Lubrication	Before fitting Silicone grease or silicone oil	None

Maintenance

12

Study the instructions carefully.
The items refer to the drawings and the parts list on page 16-19.

Handle scrap correctly.
NO = Normally open.
NC = Normally closed.

2. Dismantling

1

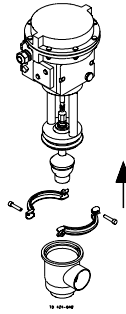

1. Supply compressed air and current of 20mA to open the NC version.
Pay special attention to the warnings!
2. Remove clamp (3).
3. Remove the actuator and the internal valve parts.
4. Remove seal ring (4c).

2

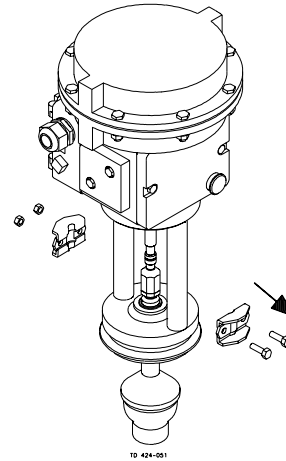

Loosen and remove clamp fitting (9).

3

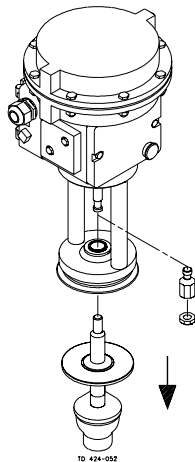

1. Loosen and unscrew lock nut (8) and valve plug adjuster (7), using a spanner.
2. Remove valve plug (2).

4

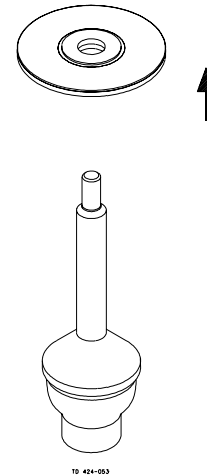

Pull off lip seal (4a) and plate (4b).

5

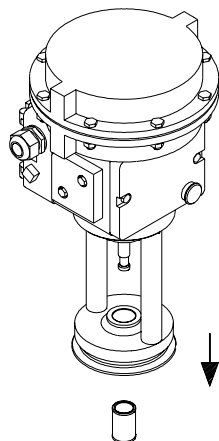

1. Remove bearing (6).
2. Replace the bearing lip seal (4a) and seal ring (4c).

6

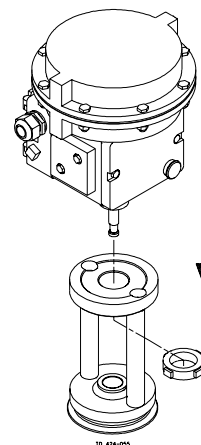

1. Loosen striking nut (10) using a plastic-hammer.
2. Separate actuator (11) from bonnet (5).

Study the instructions carefully.
The items refer to the drawings and the parts list on page 16-19.

Lubricate the lip seal before fitting it.
NO = Normally open.
NC = Normally closed.

3. Reassembly

1

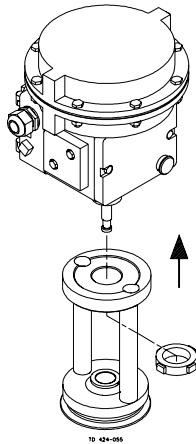

1. Fit bonnet (5) on actuator (11).
2. Tighten striking nut (10) using a plastic-hammer.

2

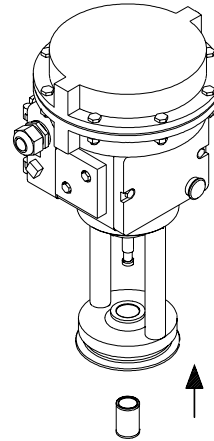

Fit bearing (6) in bonnet (5).

3

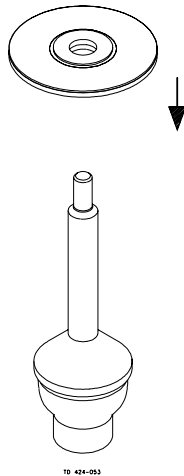

Fit lip seal (4a) and plate (4b) on valve plug (2).

4

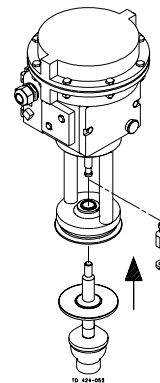

Screw lock nut (8) and valve plug adjuster (7) onto valve plug (2).

5

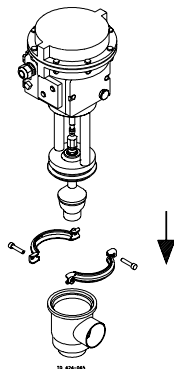

1. Supply compressed air and current of 20 mA to open the NC version.
Pay special attention to the warnings!
2. Fit seal ring (4c) in valve body (1).
3. Fit the actuator and the internal valve parts.
4. Fit and tighten clamp (3).

6

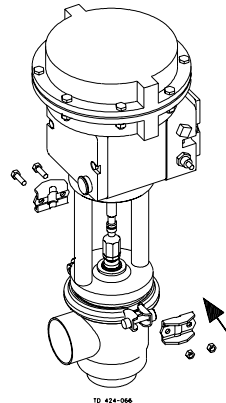

1. Adjust the valve plug adjuster so that it contacts the actuator piston rod.
2. Tighten lock nut (8) using a spanner.
3. Fit and tighten clamp fitting (9) to connect the actuator piston rod with valve plug (2).

Technical data

14

It is important to observe the technical data during installation, operation and maintenance.

Inform the personnel about the technical data.

1. Technical data

Valve-data

Max. product pressure	1000kPa (10bar)
Min. product pressure	Full vacuum
Temperature range	-10°C to +140°C (EPDM)
Flow range Kv	0.5 to 110 m ³ /h/bar
Max. pressure drop	500kPa (5bar)

Valve-materials

Product wetted steel parts	AISI 316L
Other steel parts	AISI 304
Lip seal	EPDM (standard)
Finish	Semi bright

Actuator-air data

Air consumption at steady state condition	With 0.6 bar signal pressure and supply pressures up to 6 bar ≤ 100 l/h
Connection	6/4 mm air tube
Max. air pressure	600kPa (6 bar)
Working pressure	400kPa (4 bar)
Max. size of particles	0.01mm
Max. oil content	0.08ppm
Dew point	10°C below ambient temp. or lower
Max. water content	7.5g/kg

Actuator-transducer/convector

Signal range	4-20mA (standard)
Input resistance	200Ω
Inductivity/capacitance	Negligible

Actuator-accuracy

Deviation	≤ 1.5%
Hysteresis	≤ 0.5%
Sensitivity	< 0.1%
Influence of air supply	≤ 0.1% between 1.4 and 6 bar

Actuator-data

Protection class	IP54
Ambient temperature	-25°C to +70°C

Actuator-materials

Housing	Aluminium with plastic coating
Diaphragm	NBR with reinforced fabric insert
Springs	Stainless steel uncovered/spring steel epoxy resin coated
Stem	Stainless steel
Plastic parts	Polycarbonate/polyamide 6.6
Screws, nuts	Stainless steel, polyamide 6.6
Other parts	Stainless steel and aluminium

Noise

One meter away from - and 1.6 meter above the exhaust the noise level of a valve actuator will be approximately 77db(A) without noise damper and approximately 72 db(A) with damper - Measured at 7 bars air-pressure.

It is important to observe the technical data during installation, operation and maintenance.

Inform the personnel about the technical data.
 NO = Normally open.
 NC = Normally closed.

2. Selection / Pressure drop - capacity diagram

NOTE!

Different springs are available for different actuator thrusts.
 Always return the actuator to the supplier if changing the springs.

Kv	Seat area (cm ²)	Seat diam. (mm)	Tube connections (mm)		Actuator (type no.)		NO Piston thrust (N), at air pressure (bar)				NC Piston thrust spring(N)
			ISO	DIN	NO	NC	3.0	4.0	5.0	6.0	
0,5 E	0.3	6	38	40	3277-5	3277-5	800	2 000	3 200	4 400	1 500
1,0 E	0.8	10	38	40	3277-5	3277-5	800	2 000	3 200	4 400	1 500
2 E	1.1	12	38	40	3277-5	3277-5	800	2 000	3 200	4 400	1 500
4 E	1.5	14	38	40	3277-5	3277-5	800	2 000	3 200	4 400	1 500
8 E	4.2	23	38	40	3277-5	3277-5	800	2 000	3 200	4 400	1 500
16 E	6.6	29	38	40	3277-5	3277-5	800	2 000	3 200	4 400	1 500
32 E	18.5	48,5	51	50	3277-5	3277-5	800	2 000	3 200	4 400	1 500
64 L	20.5	51	63,5	65	3277-5	3277-5	800	2 000	3 200	4 400	1 500
75 L	20.5	51	76	80	3277-5	3277-5	800	2 000	3 200	4 400	1 500
110 L	40.7	72	101,6	100	3277-5	3277*	800	2 000	3 200	4 400	2 800

*) Effective diaphragm area = 350 cm² (all others = 120 cm²).

What product pressure below the plug will open the valve?

$$P = \frac{F \times 10}{A} \quad (\text{kPa})$$

P = Product pressure (bar)
 A = Seat area (cm²)
 d = Seat diameter (mm)
 F = Piston thrust (N)

Example:

Kv 32E, 4 bar air pressure (NO), A = 18.5 cm², F = 2000 N

$$\Rightarrow P = \frac{2000 \times 10}{18.5} = 1080 \text{ kPa} \approx 10.8 \text{ bar}$$

The valve opens at product pressure above 10 bar.

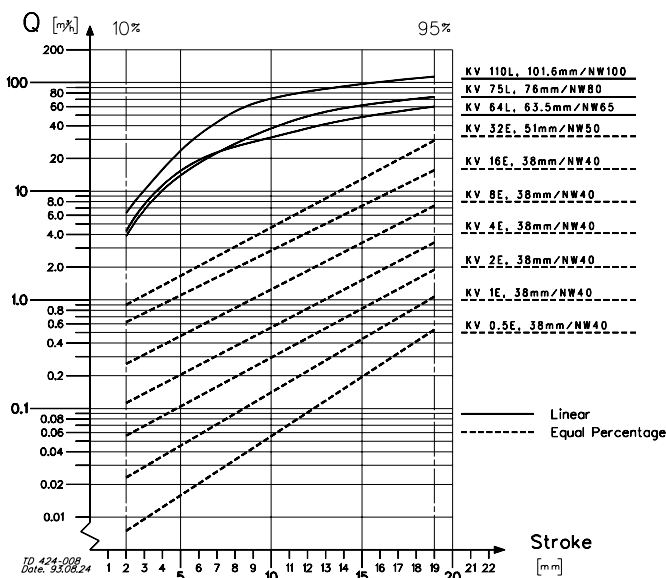

Pressure Drop Calculation

The Kv designation is the flow rate in m³/h at a pressure drop of 1 bar when the valve is fully open (water at 20°C or similar liquids). The Kv value at other pressure drops is calculated according to the following formular:

$$Kvq = \frac{Q}{\sqrt{\Delta p}}$$

Where:

Kvq = Flow coefficient (m³/h at Δp = 1 bar).
 Q = Flow rate (m³/h).
 Δp = Pressure drop over valve (bar).

Drawing/Parts list

The drawing and the parts list include all items.

The items are identical with the items in the Spare Parts List.
When ordering spare parts, please use the Spare Parts List!

Parts list SPC-2

16

Item	Qty.	Denomination
1	1	Valve body
2	1	Valve plug
3	1	Clamp
4	1	Lip seal kit
4a Δ	1	Lip seal
4b	1	Plate
	1	Plate for FEP seal
4c Δ	1	Seal ring
	1	Seal ring for FEP seal
4d	1	Support ring for FEP seal
4e Δ	1	O-ring for FEP seal
5	1	Bonnet
6 Δ	1	Bearing
7	1	Valve plug adjuster
8	1	Lock nut
9	1	Clamp fitting
10	1	Striking nut
11	1	Actuator

Δ : Service kits - EPDM, NBR, FPM
(See Spare Parts List)

This page shows an exploded drawing of SPC-2.
NO = Normally open.
NC = Normally closed.

The drawing includes all items of the valve.
They are identical with the items in the Spare Parts List

Exploded drawing

Parts for FEP seal

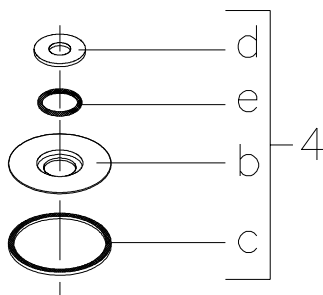

SP 424-002

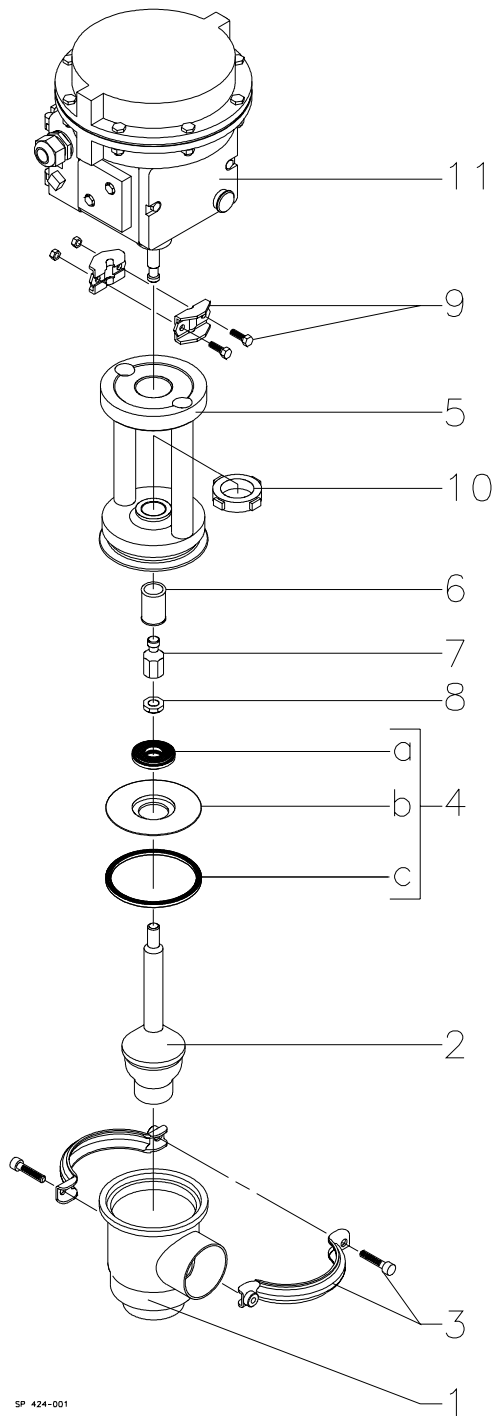

SP 424-001

Drawing/Parts list

The drawing and the parts list include all items.

The items are identical with the items in the Spare Parts List.

When ordering spare parts, please use the Spare Parts List!

Parts list SPC-2

18

Item	Qty.	Denomination
1	1	Valve body
2	1	Valve plug
3	1	Clamp
4	1	Lip seal kit
4a Δ	1	Lip seal
4b	1	Plate
	1	Plate for FEP seal
4c Δ	1	Seal ring
	1	Seal ring for FEP seal
4d	1	Support ring for FEP seal
4e Δ	1	O-ring for FEP seal
5	1	Bonnet
6 Δ	1	Bearing
7	1	Valve plug adjuster
8	1	Lock nut
9	1	Clamp fitting
10	1	Striking nut
11	1	Actuator

Δ : Service kits - EPDM, NBR, FPM
(See Spare Parts List)

The drawing below shows SPC-2, NO and NC version.

NO = Normally open.

NC = Normally closed.

The items refer to the parts list on the opposite part of the page.

Drawings

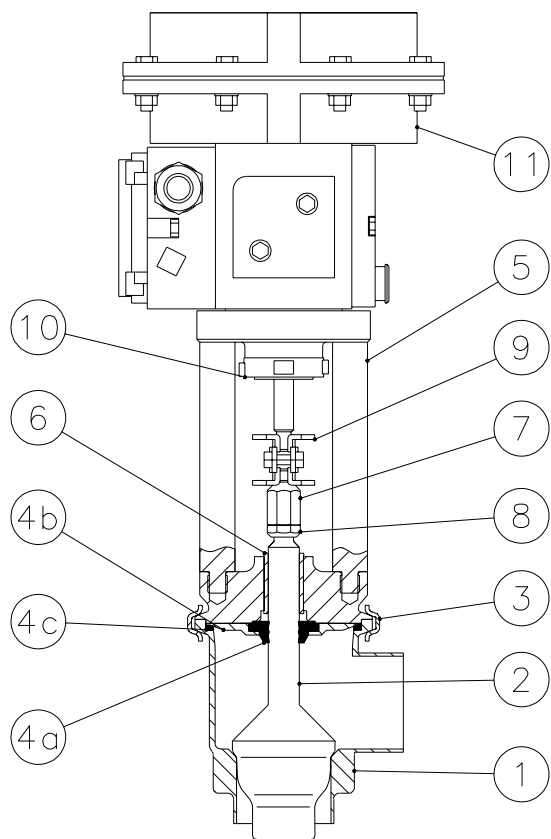
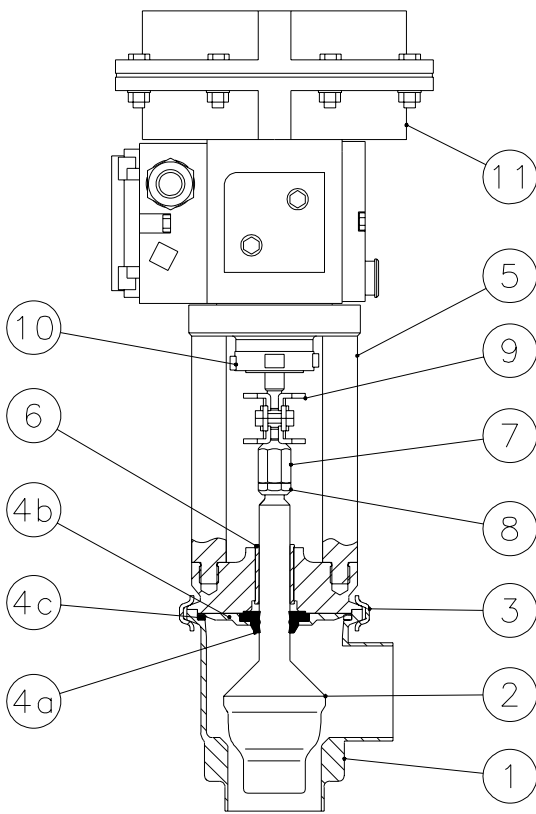

TD 424-058

How to contact Alfa Laval

Contact details for all countries are continually updated on our website. Please visit www.alfalaval.com to access the information direct.