

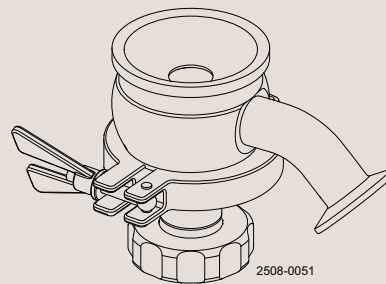

# Instruction Manual

## Radial Diaphragm Valve UltraPure

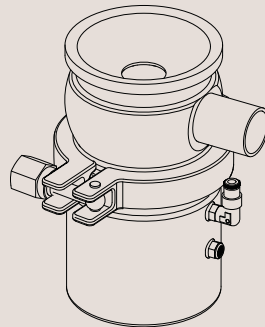
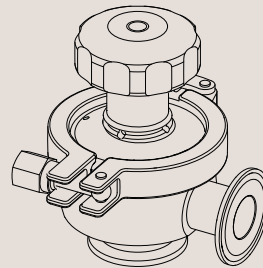
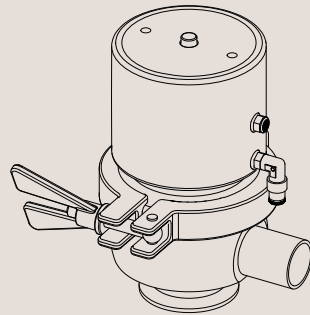

ESE02132-ENUS1 2011-11

Original manual



## Table of contents

*The information herein is correct at the time of issue but may be subject to change without prior notice*

<b>1. EC Declaration of Conformity</b> .....	<b>4</b>
<b>2. Safety</b> .....	<b>5</b>
2.1. Important information .....	5
2.2. Warning signs .....	5
2.3. Safety precautions .....	6
<b>3. Installation</b> .....	<b>7</b>
3.1. Unpacking/delivery .....	7
3.2. General installation .....	9
3.3. Welding .....	11
3.4. Recycling information .....	13
<b>4. Operation</b> .....	<b>14</b>
4.1. Operation .....	14
4.2. Troubleshooting .....	15
4.3. Recommended cleaning .....	17
<b>5. Maintenance</b> .....	<b>20</b>
5.1. General maintenance .....	20
5.2. Dismantling of valve .....	22
5.3. Diaphragm replacement .....	23
5.4. Assembly of valve .....	25
5.5. Disassembly of actuator .....	26
5.6. Assembly of actuator .....	29
<b>6. Technical data</b> .....	<b>30</b>
6.1. Technical data .....	30
<b>7. Parts list and Service Kits</b> .....	<b>32</b>
7.1. Radial Diaphragm Valve UltraPure - Shut off - Actuator .....	32
7.2. Radial Diaphragm Valve UltraPure - Shut off - Manual .....	34
7.3. Radial Diaphragm Valve UltraPure - Tank Outlet - Actuator .....	36
7.4. Radial Diaphragm Valve UltraPure - Tank Outlet - Manual .....	38

# 1 EC Declaration of Conformity

The designating company

Alfa Laval

Company Name

Albuen 31, DK-6000 Kolding, Denmark

Address

+45 79 32 22 00

Phone No.

hereby declare that

Radial Diaphragm Valve UltraPure

Denomination

Diaphragm Valves

Type

Year

is in conformity with the following directives:

- Machinery Directive 2006/42/EC

- Pressure Equipment Directive 97/23/EC category 1 and subjected to assessment procedure Module A.

Note: Tank outlet valve is not prepared for build into pressure vessels according to PED/ASME, but only into "open" vessels.

Manager, Product Centres, Compact  
Heat Exchangers & Fluid Handling

Title

Bjarne Søndergaard

Name

Alfa Laval Kolding  
Company

Signature



Designation



*Unsafe practices and other important information are emphasized in this manual.  
Warnings are emphasized by means of special signs.*

---

### 2.1 Important information

---

**Always read the manual before using the valve!**

**WARNING**

Indicates that special procedures must be followed to avoid serious personal injury.

**CAUTION**

Indicates that special procedures must be followed to avoid damage to the valve.

**NOTE**

Indicates important information to simplify or clarify procedures.

---

### 2.2 Warning signs

---

General warning:



Caustic agents:



## 2 Safety

---

All warnings in the manual are summarized on this page.

Pay special attention to the instructions below so that severe personal injury and/or damage to the valve are avoided.

---

### 2.3 Safety precautions

---

#### Installation:

**Always** read the technical data thoroughly (See chapter 6)

**Always** release compressed air after use

**Never** touch the moving parts if the actuator is supplied with compressed air

**Never** touch the valve or the pipelines when processing hot liquids or when sterilizing

**Never** dismantle the valve with valve and pipelines under pressure

**Never** dismantle the valve when it is hot



#### Operation:

**Never** dismantle the valve with valve and pipelines under pressure

**Never** dismantle the valve when it is hot

**Always** read the technical data thoroughly (See chapter 6)

**Always** release compressed air after use

**Never** touch the valve or the pipelines when processing hot liquids or when sterilizing

**Never** touch the moving parts if the actuator is supplied with compressed air

**Always** rinse well with clean water after the cleaning

**Always** handle lye and acid with great care



#### Maintenance:

**Always** read the technical data thoroughly (See chapter 6)

**Always** release compressed air after use

**Never** service the valve when it is hot

**Never** service the valve with valve and pipelines under pressure

**Never** stick your fingers through the valve ports if the actuator is supplied with compressed air

**Never** touch the moving parts if the actuator is supplied with compressed air



#### Transportation:

**Always** secure that compressed air is released

**Always** secure that all connections are disconnected before attempt to remove the valve from the installation

**Always** drain liquid out of valves before transportation

**Always** used predesigned lifting points if defined

**Always** secure sufficient fixing of the valve during transportation - if special designed packaging material is available it must be used

---

## 3 Installation

*The instruction manual is part of the delivery. Study the instructions carefully.  
The items refer to parts list and service kits section.  
The valve is supplied as separate parts as standard (for welding).*

### 3.1 Unpacking/delivery

#### Step 1

##### CAUTION

Alfa Laval cannot be held responsible for incorrect unpacking.

##### Check the delivery for:

1. Complete valve, shut off valve, tank outlet, manual shut off or manual tank outlet valve (see steps 2 and 3).
2. Delivery note.
3. Instruction Manual.
4. Q doc Manual.

#### Step 2

##### Shut-off valve and tank outlet valve

1. Complete actuator.
2. Diaphragm.
3. Clamp (wingnut or hexnut).
4. Valve body.

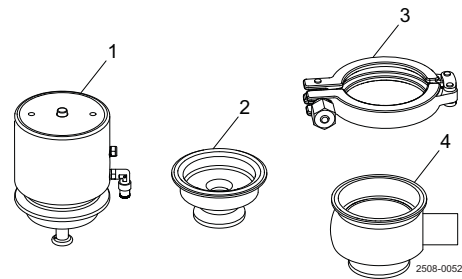

#### Step 3

##### Manual shut-off valve and tank outlet valve

1. Manual actuator.
2. Diaphragm.
3. Clamp (wingnut or hexnut).
4. Lower valve body.

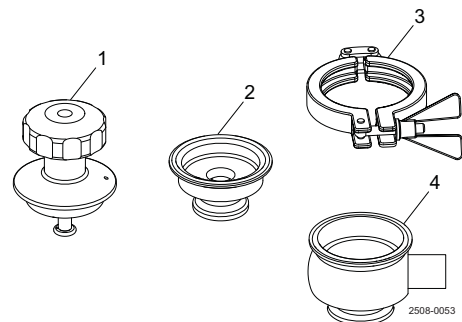

#### Step 4

Remove any possible packing materials from the valve/valve parts

### 3 Installation

---

*The instruction manual is part of the delivery. Study the instructions carefully.  
The items refer to parts list and service kits section.  
The valve is supplied as separate parts as standard (for welding).*

---

#### **Step 5**

Inspect the valve and valve parts for visible transport damages.  
Avoid damaging the valve and valve parts.  
Check that the Q-doc. serial number and the "Q-doc manual number" is identical.

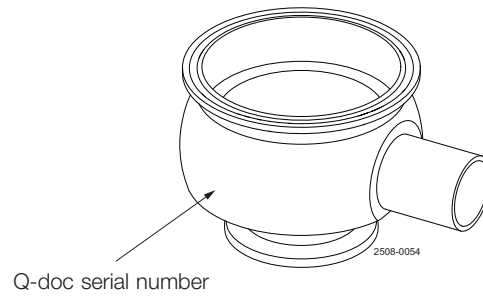



## 3 Installation

Study the instructions carefully and pay special attention to the warnings!

The valve has welding ends and clamp fitting in bottom as standard but can also be supplied with clamp fittings on the port ends.

### 3.2 General installation

#### Step 1



**Always** read the technical data thoroughly.  
See chapter 6



**Always** release compressed air after use.

#### CAUTION

Alfa Laval cannot be held responsible for incorrect installation.

#### Step 2



**Never** touch the moving parts if the actuator is supplied with compressed air.

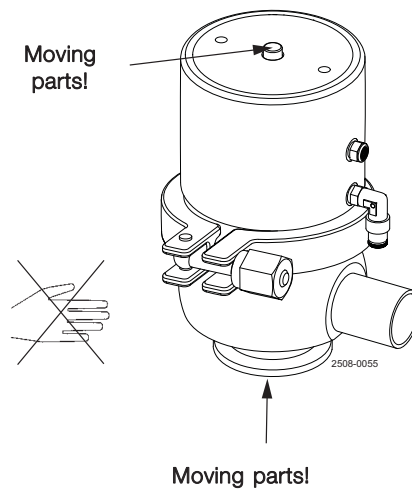

#### Step 3

Avoid stressing the valve.

#### Pay special attention to:

- Vibrations.
- Thermal expansion of the pipelines.
- Excessive welding.
- Overloading of the pipelines.

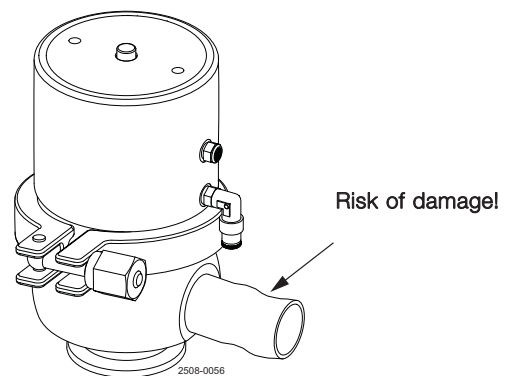

### 3 Installation

---

*Study the instructions carefully and pay special attention to the warnings!*

*The valve has welding ends and clamp fitting in bottom as standard but can also be supplied with clamp fittings on the port ends.*

---

#### Step 4

It is recommended to install the valve so that the flow is against the closing direction to avoid water hammer.

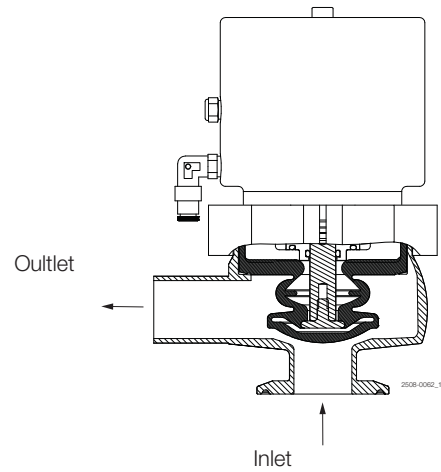

#### Step 5

It is recommended that the leakage hole in the pneumatic/manual actuator is placed so it is visible.

If there is fluid seeping from the leakage hole is the diaphragm worn out and must be replaced.

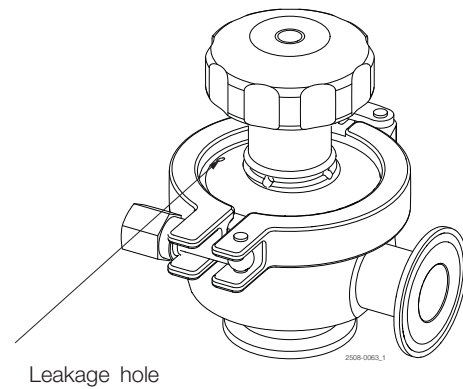

### 3 Installation

Study the instructions carefully.

The valve is supplied as separate parts to facilitate the welding. The items refer to the parts list and service kits section. Check the valve for smooth operation after welding. Man = Manually open and close, NC= Normally closed.

#### 3.3 Welding

##### Step 1

Always weld the valve so that the actuator with the internal parts can be removed.

Valve size DN/OD	A mm (inch) Air actuator	B mm (inch) Manual actuator
12.7 mm (½ inch)	132 mm (5.2 inch)	92 mm (3.6 inch)
25 mm (1 inch)	168 mm (6.6 inch)	98 mm (3.9 inch)
38 mm (1½ inch)	182 mm (7.1 inch)	112 mm (4.4 inch)

**NOTE!** If there is a risk of foot damage, Alfa Laval recommends to leave a distance of 120 mm (4.7") below the actuator.

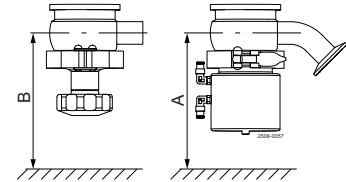

##### Step 2

##### Placement of the tank outlet valve

The valve housing is usually placed according to the figure below, but other locations may exist

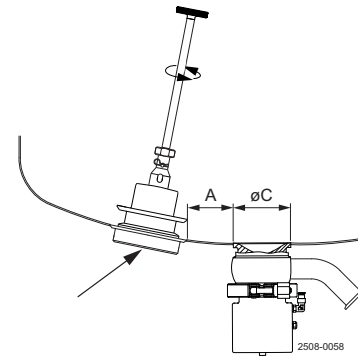

e.g. Weldplate mixer

A = Min. distance between the weld in components, in accordance with the PED.

Valve size	Diameter of weld flange (hole) øC
12.7 mm / ½ inch	ø50 mm / 1.97 inch
25 mm / 1 inch	ø79 mm / 3.11 inch
38 mm / 1½ inch	ø85 mm / 3.35 inch

A hole (see table) for the valve is cut in the tank plate.

Grind the edge so there are no gab between valve and tank plate.

**Only** use pulsed arc welding. (Low heat input) to avoid deform the valve body.

Tack weld **always** on the opposite side (8 segments with filler metal).

Weld root if possible without filler metal.

Welding of the final run must be done in 8 segments to avoid crack.

The inside and outside of the weld is ground and polished to required finish.

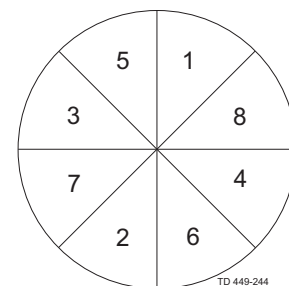

### 3 Installation

---

*Study the instructions carefully.*

*The valve is supplied as separate parts to facilitate the welding. The items refer to the parts list and service kits section. Check the valve for smooth operation after welding. Man = Manually open and close, NC= Normally closed.*

---

#### Step 3

##### Shut off and tank outlet valves:

Assemble the valve in accordance with the steps in section 5.3.

1. Supply compressed air to the actuator.
2. Open and close the valve several times to ensure that it operates smoothly.

**Pay special attention to the warnings!**

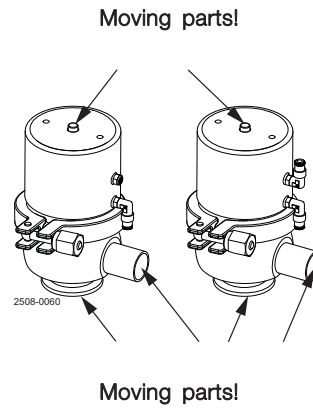

*Study the instructions carefully.*

*The valve is supplied as separate parts to facilitate the welding. The items refer to the parts list and service kits section. Check the valve for smooth operation after welding. Man = Manually open and close, NC= Normally closed.*

---

### 3.4 Recycling information

---

- **Unpacking**

- Packing material consists of wood, plastics, cardboard boxes and in some cases metal straps
- Wood and cardboard boxes can be reused, recycled or used for energy recovery
- Plastics should be recycled or burnt at a licensed waste incineration plant
- Metal straps should be sent for material recycling

- **Maintenance**

- During maintenance oil and wear parts in the machine are replaced
- All metal parts should be sent for material recycling
- Worn out or defective electronic parts should be sent to a licensed handler for material recycling
- Oil and all non metal wear parts must be taken care of in agreement with local regulations

- **Scrapping**

- At end of use, the equipment shall be recycled according to relevant, local regulations. Beside the equipment itself, any hazardous residues from the process liquid must be considered and dealt with in a proper manner. When in doubt, or in the absence of local regulations, please contact the local Alfa Laval sales company
-

## 4 Operation

Study the instructions carefully and pay special attention to the warnings!

Ensure that the valve operates smoothly.

The items refer to the parts list and service kits section.

A-A = Air open and close, NC= Normally closed.

### 4.1 Operation

#### Step 1



**Always** read the technical data thoroughly.

See chapter 6.



**Always** release compressed air after use.

#### CAUTION

Alfa Laval cannot be held responsible for incorrect operation.

#### Step 2



**Never** touch the valve or the pipelines when processing hot liquids or when sterilizing.

The manually handle will get hot - use hand protection if the valve must be operated.

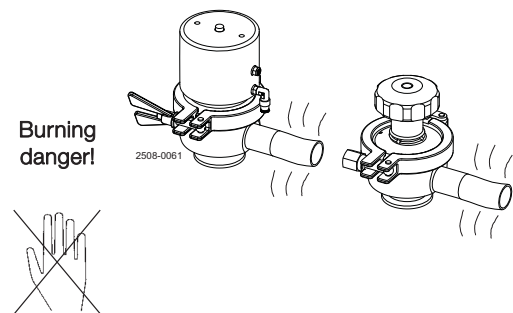

#### Step 3



**Never** touch the moving parts if the actuator is supplied with compressed air.

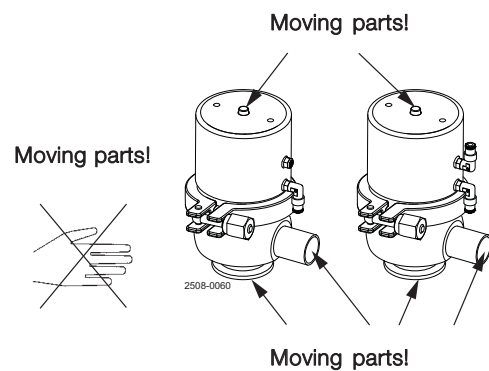

*Pay attention to possible faults. Study the instructions carefully.  
The items refer to the parts list and service kits section.*

### 4.2 Troubleshooting

Problem	Possible cause	Repair
Manual valve does not open when actuator is turned counter-clockwise.	<ol style="list-style-type: none"> <li>1. Diaphragm has stuck.</li> <li>2. Diaphragm is not properly mounted on the actuator.</li> <li>3. Actuator is broken.</li> <li>4. Incorrect flow direction in combination with high fluid pressure.</li> </ol>	<ol style="list-style-type: none"> <li>1. Inspect diaphragm and replace it if required.</li> <li>2. Correct mounting. Some force must be used to push the actuator into the diaphragm.</li> <li>3. Inspect and replace if required.</li> <li>4. Correct flow direction or lower fluid pressure.</li> </ol>
Manual valve does not close when actuator is turned clockwise.	<ol style="list-style-type: none"> <li>1. Incorrect flow direction in combination with high fluid pressure.</li> <li>2. Actuator is broken.</li> </ol>	<ol style="list-style-type: none"> <li>1. Correct flow direction or lower fluid pressure.</li> <li>2. Inspect and replace id required.</li> </ol>
Pneumatic valve does not open when opened via a solenoid valve.	<ol style="list-style-type: none"> <li>1. Diaphragm has stuck.</li> <li>2. Diaphragm is not properly mounted on the actuator.</li> <li>3. Actuator is broken.</li> <li>4. Compressed air supply is too low.</li> <li>5. Pneumatic hose is damaged.</li> <li>6. Solenoid valve fault or forced in wrong position manually.</li> <li>7. Incorrect flow direction in combination with high fluid pressure.</li> </ol>	<ol style="list-style-type: none"> <li>1. Inspect diaphragm and replace it if required.</li> <li>2. Correct mounting. Some force must be used to push the actuator into the diaphragm.</li> <li>3. Inspect and replace is required.</li> <li>4. Check compressed air supply pressure.</li> <li>5. Replace pneumatic hose.</li> <li>6. Check that the solenoid valve is not operated manually. Replace solenoid valve.</li> <li>7. Correct flow direction or lower fluid pressure.</li> </ol>
Pneumatic valve is open all through closed via the solenoid valve.	<ol style="list-style-type: none"> <li>1. Solenoid valve fault.</li> <li>2. Electrical cable is damaged.</li> <li>3. Pneumatic system does not ventilate.</li> <li>4. Incorrect flow direction in combination with high fluid pressure.</li> </ol>	<ol style="list-style-type: none"> <li>1. Inspect and replace if required.</li> <li>2. Replace electrical cable.</li> <li>3. Check ventilation of pneumatic system.</li> <li>4. Correct flow direction or lower fluid pressure.</li> </ol>
Cleaning in CIP is not satisfactory.	<ol style="list-style-type: none"> <li>1. Cleaning chemicals wrong type or too low concentration.</li> <li>2. Flow too low.</li> <li>3. Poor draining.</li> <li>4. Flow obstructed.</li> <li>5. Diaphragm broken.</li> </ol>	<ol style="list-style-type: none"> <li>1. Analyse for correct chemicals and concentration.</li> <li>2. Increase flow.</li> <li>3. Check drainability and turn valve if required.</li> <li>4. Check flow path.</li> <li>5. Replace diaphragm.</li> </ol>

## 4 Operation

*Pay attention to possible faults. Study the instructions carefully.  
The items refer to the parts list and service kits section.*

Problem	Possible cause	Repair
Water hammer.	The flow direction is the same as the closing direction.	The flow direction should be against the closing direction.
Diaphragm has short length of line.	<ol style="list-style-type: none"><li>1. Incorrect materials for the application.</li><li>2. Media has too high temperature.</li><li>3. Air-air actuator has too high air pressure.</li><li>4. Manual is "over-tightened"</li></ol>	<ol style="list-style-type: none"><li>1. Check materials compability (EPDM or silicone).</li><li>2. Lower temperature or EPDM.</li><li>3. Reduce air pressure to 4 bar</li><li>4. Be careful not to tighten to hard.</li></ol>
External product leaking (Telltale hole).	<ol style="list-style-type: none"><li>1. Diaphragm broken.</li></ol>	<ol style="list-style-type: none"><li>1. Replace diaphragm.</li></ol>
Valve leaking.	<ol style="list-style-type: none"><li>1. Clamp not properly mounted.</li><li>2. To high fluid pressure.</li></ol>	<ol style="list-style-type: none"><li>1. Mount clamp or replace if broken.</li><li>2. Check that pressure does not exceed design pressure.</li></ol>
Actuator leaking air.	<ol style="list-style-type: none"><li>1. Sealings in actuator worn out</li></ol>	<ol style="list-style-type: none"><li>1. Replace actuator or change seals.</li></ol>



The valve is designed for cleaning in place (CIP). CIP = Cleaning In Place.  
Study the instructions carefully and pay special attention to the warnings!  
NaOH = Caustic Soda.  
HNO<sub>3</sub> = Nitric acid.

### 4.3 Recommended cleaning

#### Step 1



**Always** handle lye and acid with great care.

Caustic danger!



**Always** use  
rubber gloves!



**Always** use  
protective goggles!

#### Step 2

**Never** touch the valve of the pipelines when processing hot liquids  
or when sterilizing.

Burning  
danger!

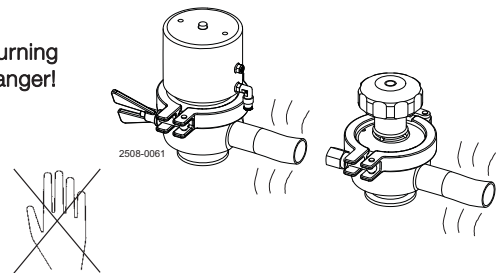

#### Step 3

Clean the plug and the seats correctly.  
Pay special attention to the warnings!  
Lift and lower diaphragm momentarily!

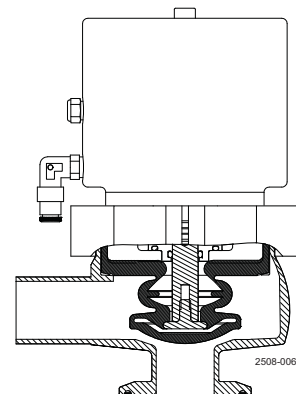

## 4 Operation

---

The valve is designed for cleaning in place (CIP). CIP = Cleaning In Place.  
Study the instructions carefully and pay special attention to the warnings!  
NaOH = Caustic Soda.  
HNO<sub>3</sub> = Nitric acid.

---

### Step 4

#### Examples of cleaning agents:

Use clean water, free from chlorides.

1. 1% by weight NaOH at 70° C (158 ° F)

1 kg NaOH	+	100 l water	=	Cleaning agent.
2.2 lb NaOH		26.4 gal water		

2.2 l 33% NaOH	+	100 l water	=	Cleaning agent.
0.6 gal 33% NaOH		26.4 gal water		

2. 0.5% by weight HNO<sub>3</sub> at 70° C (158 ° F)

0.7 l 53% HNO <sub>3</sub>	+	100 l water	=	Cleaning agent.
0.2 gal 53% HNO <sub>3</sub>		26.4 gal water		

### Step 5

1. Avoid excessive concentration of the cleaning agent.
2. Adjust the cleaning flow to the process.
3. **Always** rinse well with clean water after the cleaning.

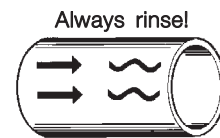

Clean water    Cleaning agents

---

### Step 6

#### NOTE

The cleaning agents must be stored/disposed of in accordance with current regulations/directives.

---

## 4 Operation

---

*The valve is designed for cleaning in place (CIP). CIP = Cleaning In Place.  
Study the instructions carefully and pay special attention to the warnings!  
NaOH = Caustic Soda.  
HNO<sub>3</sub> = Nitric acid.*

---

### Step 7 Autoclaving

The manually opened actuator is possible to autoclave.  
Max. temperature 130°C

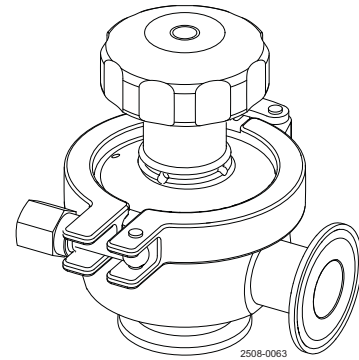

The pneumatic actuator is not possible to autoclave.

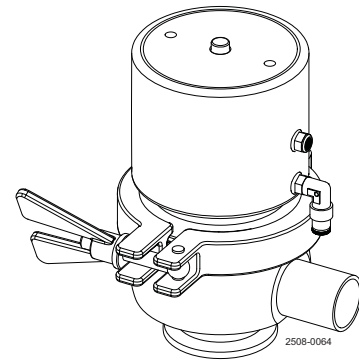

## 5 Maintenance

Maintain the valve regularly.  
Study the instructions carefully and pay special attention to the warnings!  
Always keep spare rubber seals in stock.  
Check the valve for smooth operation after service.

### 5.1 General maintenance

#### Step 1



**Always** read the technical data thoroughly.  
See chapter 6.



**Always** release compressed air after use.

#### Step 2



**Never** service the valve when it is hot.



**Never** service the valve with valve and pipelines under pressure.

#### NOTE

All scrap must be stored/discharged in accordance with current rules/directives.

Burning  
danger!

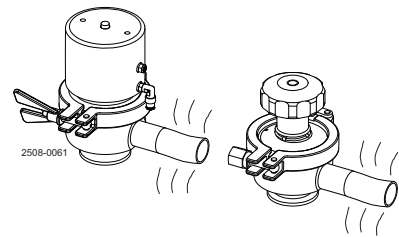

#### Step 3



**Never** stick your fingers through the valve ports if the actuator is supplied with compressed air.



**Never** touch the moving parts if the actuator is supplied with compressed air.

Cutting danger!

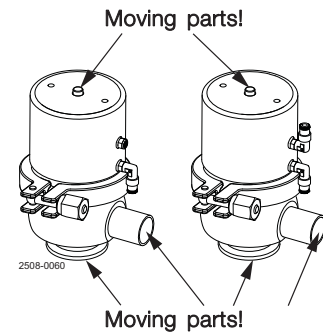
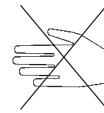

## 5 Maintenance

Maintain the valve regularly.  
 Study the instructions carefully and pay special attention to the warnings!  
 Always keep spare rubber seals in stock.  
 Check the valve for smooth operation after service.

Below are some guidelines for maintenance and lubrication intervals. Please note that the guidelines are for normal working conditions in one shift.

	Product wetted seals	Actuator
Preventive maintenance	Diaphragm replacement, see section 5.3	Special tools required for pneumatic actuator, see section 5,6 and 5,7.
Planned maintenance	<ul style="list-style-type: none"> <li>- Regular inspection for leakage and smooth operation</li> <li>- Keep a record of the valve</li> <li>- Use the statistics for planning of inspections</li> </ul> <b>Replace after leakage</b>	<ul style="list-style-type: none"> <li>- Regular inspection for leakage and smooth operation</li> <li>- Keep a record of the actuator</li> <li>- Use the statistics for planning of inspections</li> </ul> <b>Replace after leakage</b>
Lubrication	<b>Not necessary</b>	<b>Inside actuator use Kluber Paraliq GTE 703</b> But special tools required for pneumatic actuator (see section 5,6 and 5,7)

Clamps frequently should be greased at the thread with "molycole TP 42"  
 Negligence may result in damaged and stuck threads.

**Recommended spare parts**  
 Service kits (see spare parts)

## 5 Maintenance

Study the instructions carefully. The items refer to the parts list and service kits section. Handle scrap correctly.

Man = Manually activated

NC = Normally closed.

A/A = Air/air activated.

### 5.2 Dismantling of valve

#### Step 1

The actuator must be in "open position" when dismantling the clamp.

#### Danger!

**Always** make sure that there is no product pressure in the pipeline before opening the valve.

**Never** service the valve when it is hot.

1. Supply compressed air to the actuator (only NC).  
The manually handle is turned counter clockwise.
2. Loosen and remove clamp.
3. Release compressed air (only NC).
4. Lift away the actuator and diaphragm.
5. Release compressed air (only NC)
6. The manually actuator spindle must be in the "closed position" to remove the diaphragm, which is done by rotating the handle clockwise. The diaphragm is pushed away from the actuator housing.
7. Remove the diaphragm (see section 5.3)

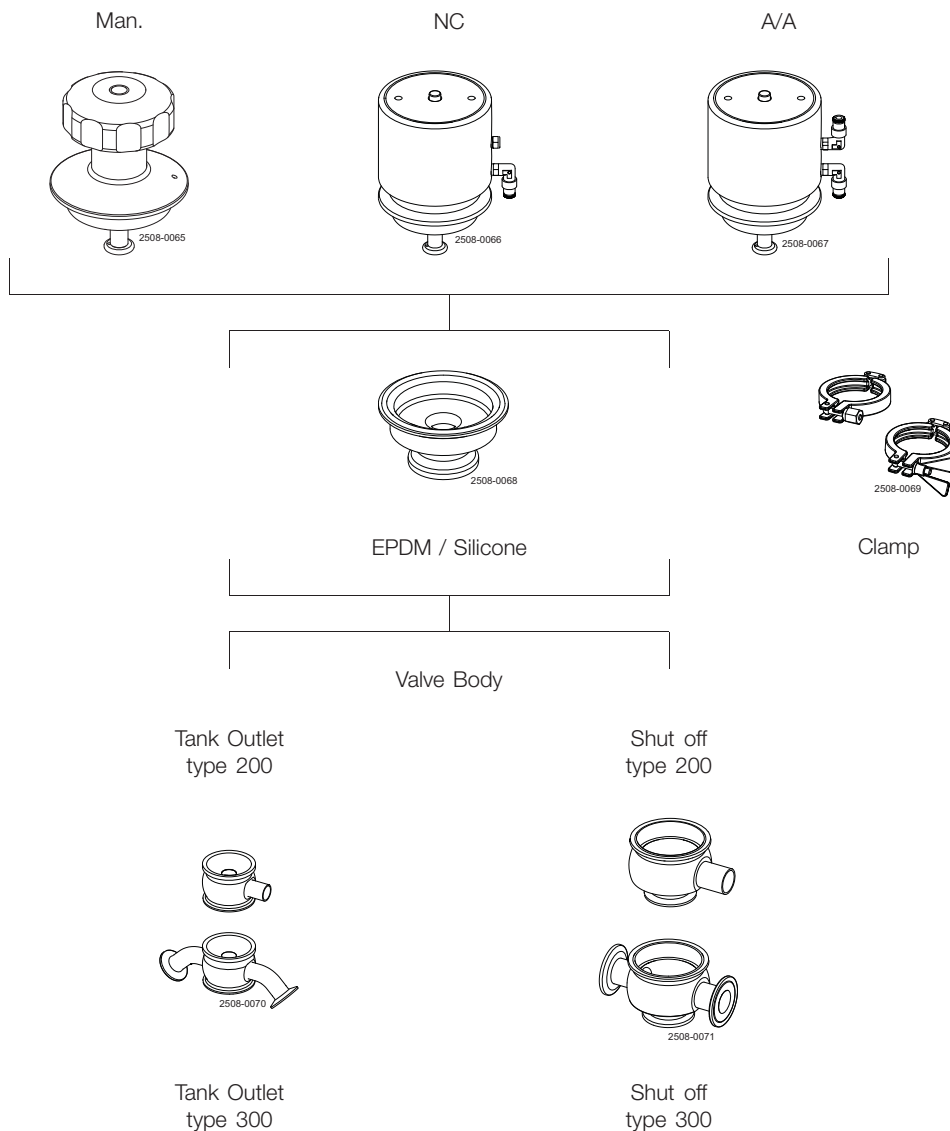

The  $\varnothing 12.7 / 1/2$  inch and the  $\varnothing 25$  mm / 1 inch is snapped on the actuator rod.

The  $\varnothing 38 / 1 1/2$  inch is screwed onto the actuator spindle.

Study the instructions carefully. The items refer to the parts list and service kits section. Handle scrap correctly.

Man = Manually activated

NC = Normally closed.

A/A = Air/air activated.

### 5.3 Diaphragm replacement

The diaphragm seals against the valve body seat while the valve is closed. The diaphragm also operates as a static seal. There are two sealing faces between the valve housing and the actuator. The diaphragm is available in EPDM and Silicone.

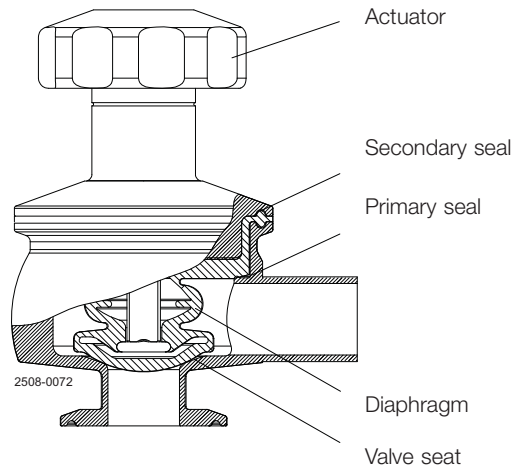

The material that the diaphragms is made of, will be affected by parameters as temperature, pressure, media, activations and combinations of these parameters.

The service life to the diaphragm depends on its working conditions.

In general, inspection should be made at every 50 hours of sterilisation (e.g. exposure to steam or super heated water).

The interval may however vary between different installations, depending on chemicals and utilities used, and temperature during SIP. The following guidelines can be used:

1. Exposure to water < 100°C.  
The diaphragm should be inspected after approx. 1000 hours of operation.
2. Exposure to steam > 100 °C, but max. 135 °C (1 hour).  
The diaphragm should be inspected after approx. 50 hours exposure, e.g. after 50 sterilisation of 60 minutes.
3. For EPDM diaphragms which are subjected constantly to pure steam, the interval of inspection can typically be extended to about 250 hours.  
Use an on/off valve before the valve to prolong length of life of EPDM membrane.

Table 1. Diaphragm size (silicone or EPDM)

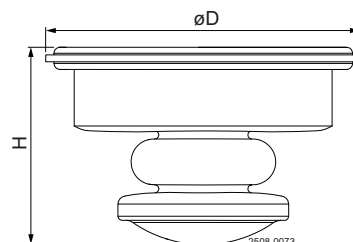

mm	Size	inch	ØD	H
12.7		½	50.5 (2 inch)	31 (1 ¼inch)
25		1	77.5 (3 inch)	50 (2 inch)
38		1½	77.5 (3 inch)	57 (2 ¼inch)

## 5 Maintenance

Study the instructions carefully. The items refer to the parts list and service kits section. Handle scrap correctly.

Man = Manually activated

NC = Normally closed.

A/A = Air/air activated.

### Diaphragm marking

#### Fig. A

Size 12.7 / 1/2 inch and 25 / 1 inch is "a snap connection". The diaphragm must be all the way on, or it will be over-stretched and damaged in the closed position. Some force may be needed to push the diaphragm over the "snap connection".

The diaphragm is mounted onto the actuator rod (which must be in the close position) = diaphragm is uncompressed.

#### Fig. B

Size 38 (1 1/2) is a screwed connection.

**NOTE!** The manually actuator must be locked by using e.g. a small screwdriver into the ø4 hole in the rod (ø4 hole is only in the manually rod and not the pneumatic version).

The diaphragm is mounted onto the actuator rod (which must be in the close position) = diaphragm is uncompressed.

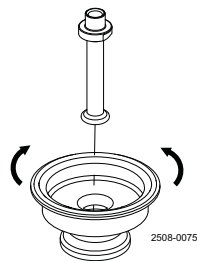

Figure A

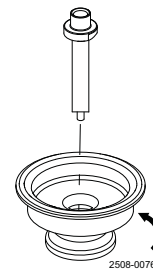
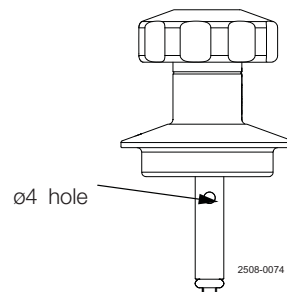

Figure B





## 5 Maintenance

---

*Study the instructions carefully. The items refer to the parts list and service kits section. Handle scrap correctly.*

*Man = Manually activated*

*NC = Normally closed.*

*A/A = Air/air activated.*

---

### 5.4 Assembly of valve

---

#### Step 1

Start with fitting the diaphragm onto the actuator rod (see section 5.3)

---

#### Step 2

To assemble the actuator into the valve body, must the actuator be in open position (diaphragm is then compressed) when assembling the valve.

Supply compressed air to the actuator (only NC and A/A).

The manually handle is turned counter clockwise.

---

#### Step 3

Mount the clamp and be sure that it is fitted correctly. Knock e.g. with a plastic hammer on both side of the clamp while tightening.

---

#### Step 4

Release compressed air (only NC + A/A).

---

## 5 Maintenance

Study the instructions carefully. The items refer to the parts list and service kits section. Handle scrap correctly.

Man = Manually activated

NC = Normally closed.

A/A = Air/air activated.

### 5.5 Disassembly of actuator

#### Step 1

##### Manual actuator

The manual operated actuator can not be dismantled.

The reason is that the lifetime is very long due to a few activations compared to the pneumatic actuator.

#### NOTE:

In case where it is chosen to dismantle can this be done without danger as there are no springs inside.

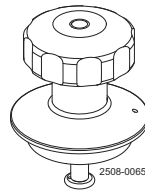

#### Step 2



##### Pneumatic actuator



**Always** release compressed air before dismantling the actuator.

The pneumatic actuator can be dismantled by using a special tool. (the article no. is shown in the spare part).

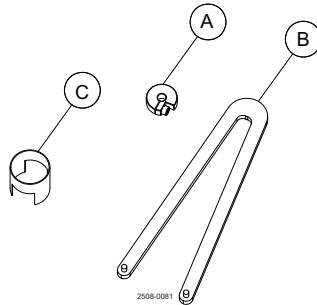

A = Tool to lock the actuator rod to avoid breaking the "spring guides" inside the actuator.

B = Tool to loosen actuator cap (spanner wrench)

C = Distance piece

#### Type A-A:

In the pneumatic actuator type A-A is there no spring inside the housing.

The actuator can therefore be opened only by using the special tool "B".

It is not necessary to use special tool "A" and "C".

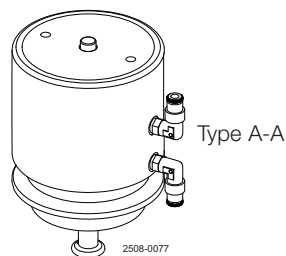

## 5 Maintenance

Study the instructions carefully. The items refer to the parts list and service kits section. Handle scrap correctly.

Man = Manually activated

NC = Normally closed.

A/A = Air/air activated.

### Type NC:

In the pneumatic actuator type NC  $\varnothing 12.7$  mm / 1/2 inch is there no "spring guides" inside the housing.

The actuator can therefore be opened only by the special tool "B".

It is not necessary to use special tool "A" and "C".

In the pneumatic actuator type NC size  $\varnothing 25$  mm / 1 inch and  $\varnothing 38$  mm / 1 1/2 inch is there "spring guides" inside the housing.

This is why it is necessary to use the special tool "A", "B" and "C".

- 1) Remove pressure plate  
Be careful not to scratch the rod.

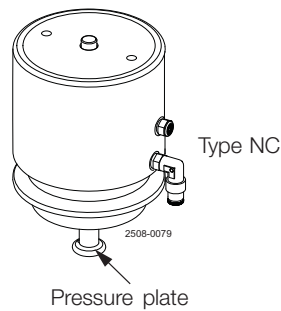

- 2) Put air on actuator and activate.

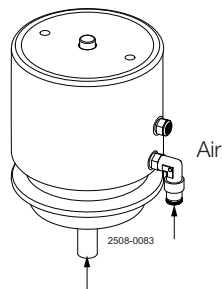

## 5 Maintenance

Study the instructions carefully. The items refer to the parts list and service kits section. Handle scrap correctly.

Man = Manually activated

NC = Normally closed.

A/A = Air/air activated.

3) With actuator compressed mount "A" (locking tool) and tighten properly.

4) RELEASE COMPRESSED AIR and remove the hose  
The "A" (locking tool) should still lock the rod.

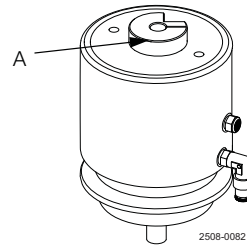

**CAREFULLY - Spring under load**

5) Unscrew cap with tool "B" (spanner wrench)

6) Remove "piston unit" from housing and handle it careful as spring are under load.

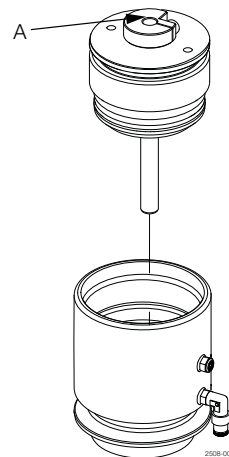

## 5 Maintenance

Study the instructions carefully. The items refer to the parts list and service kits section. Handle scrap correctly.

Man = Manually activated

NC = Normally closed.

A/A = Air/air activated.



**CAREFULLY** - Spring under load

7) Fit "C" (distance piece) so it is possible to loosen "A" (locking tool).

This must be done in a hydraulic press.

Compress cap and piston and loosen the tool "A" (locking tool) in the compressed state.

Hydraulic press

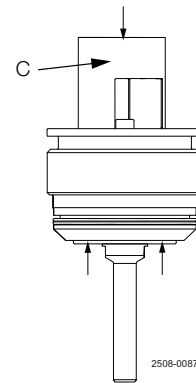

8) With the tool "A" loosen, now slowly release the compression in the hydraulic press.

**Careful as springs are under load.**

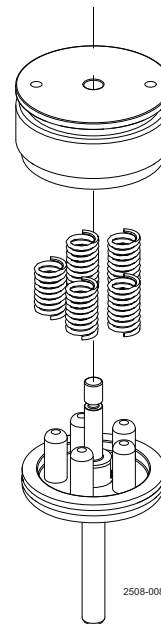
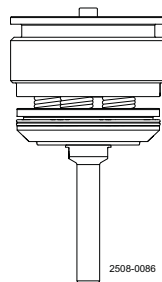

### 5.6 Assembly of actuator



**CAREFULLY** - Spring under load

**Step 1**

Assembly is done in reverse order as shown in the "Disassembly of actuator", (See section 5.5)

## 6 Technical data

Study the instructions carefully. The items refer to the parts list and service kits section. Handle scrap correctly.

Man = Manually activated

NC = Normally closed.

A/A = Air/air activated.

### 6.1 Technical data

<b>Design temperature</b>	
Sterilisation In Place (SIP)	Max. 135°C / (275 ° F (at 1 hour)
<b>Autoclave clearing</b>	
Pneumatic actuator is not possible to autoclave. Manual actuator can be autoclave. Autoclave (manual valves only is possible to autoclave)	
	Max. 130°C (266 ° F (at 1 hour)
<b>Design pressure</b>	
Minimum working pressure	Full vacuum
Maximum working pressure	7 bar (101 PSI)
<b>Other design data</b>	
pH range	3-11
Viscosity	0-1000 cP
<b>Material</b>	
Housing (valve body)	AISI 316L
Actuator cover	AISI 304
<b>Diaphragm</b>	
Silicone	According to FDA specification of approved material (FDA 21 CFR § 177.2600)
EPDM	According to FDA specification of approved material (FDA 21 CFR § 177.2600)
See section 5.3 for information about the diaphragms	
<b>Surface treatment</b>	
Internally	High grade polished Ra 0.5 µm or (SF1) electro polish Ra 0.4 µm (SF4)
Externally	Ra 0.8 µm
<b>Operating data for pneumatic actuator</b>	
<b>Actuator function:</b>	
SA: Pneumatic upward movement, spring return (NC) AA: Pneumatic upward and downward movement Man: Manually operated	
<b>Operating data: Pneumatic actuator (Spring operated) SA</b>	
Control air	Dry, free from particles and oil (ISO 8573.1 Class 2.2.1)
Supply pressure, recommended	6 bar (88 PSI)
Supply pressure minimum	5,5 bar (79 PSI)
Supply pressure, maximum	7 bar (101 PSI)
<b>Operating data - Pneumatic actuator (Air operated) AA</b>	
Control air	Dry, free from particles and oil (ISO 8573.1 Class 2.2.1)
Supply pressure, recommended	3,5 bar (51 PSI)
Supply pressure, minimum	3 bar (44 PSI)
Supply pressure, maximum	4 bar (58 PSI)
<b>Air consumption - Pneumatic actuators (AA &amp; SA)</b>	
Air consumption RDV-UP ½"	0.03 NI/stroke at 4 bar
Air consumption RDV-UP 1"	0.12 NI/stroke at 4 bar
Air consumption RDV-UP 1 ½"	0.3 NI/stroke at 4 bar
Air connection	M5 thread
Hose, quick connection	4mm hose

## 6 Technical data

Study the instructions carefully. The items refer to the parts list and service kits section. Handle scrap correctly.

Man = Manually activated

NC = Normally closed.

A/A = Air/air activated.

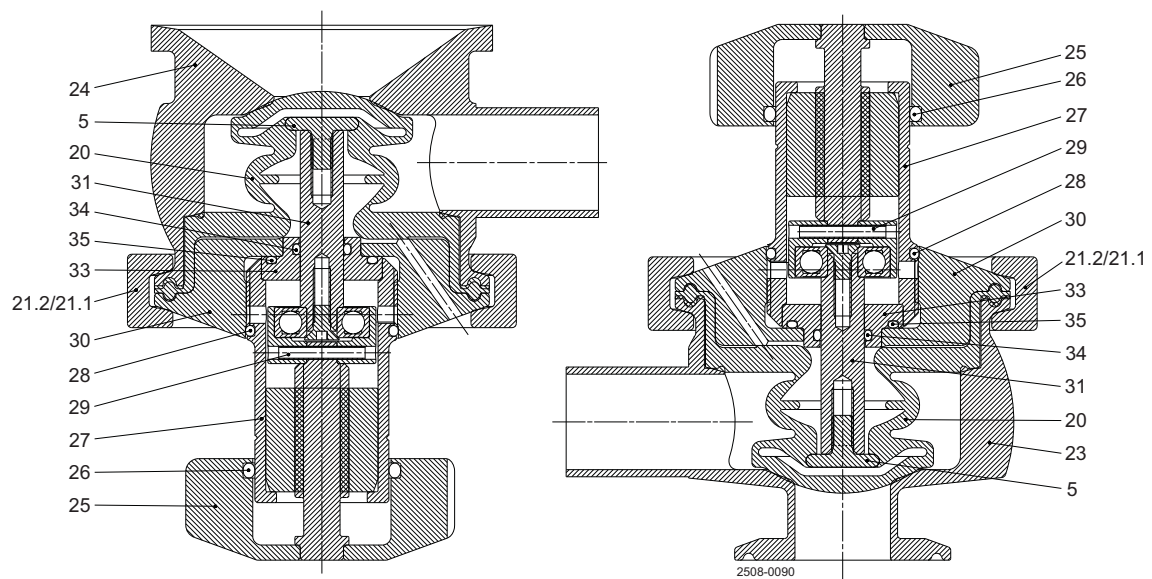
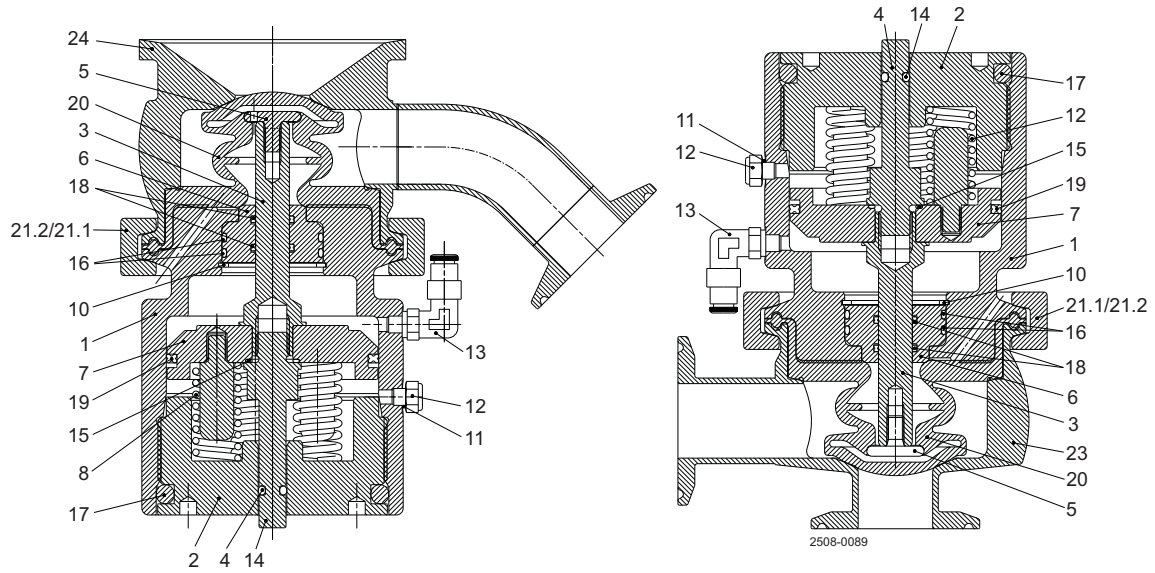

## 7 Parts list and Service Kits

Study the instructions carefully. The items refer to the parts list and service kits section. Handle scrap correctly.

Man = Manually activated

NC = Normally closed.

A/A = Air/air activated.

### 7.1 Radial Diaphragm Valve UltraPure - Shut off - Actuator

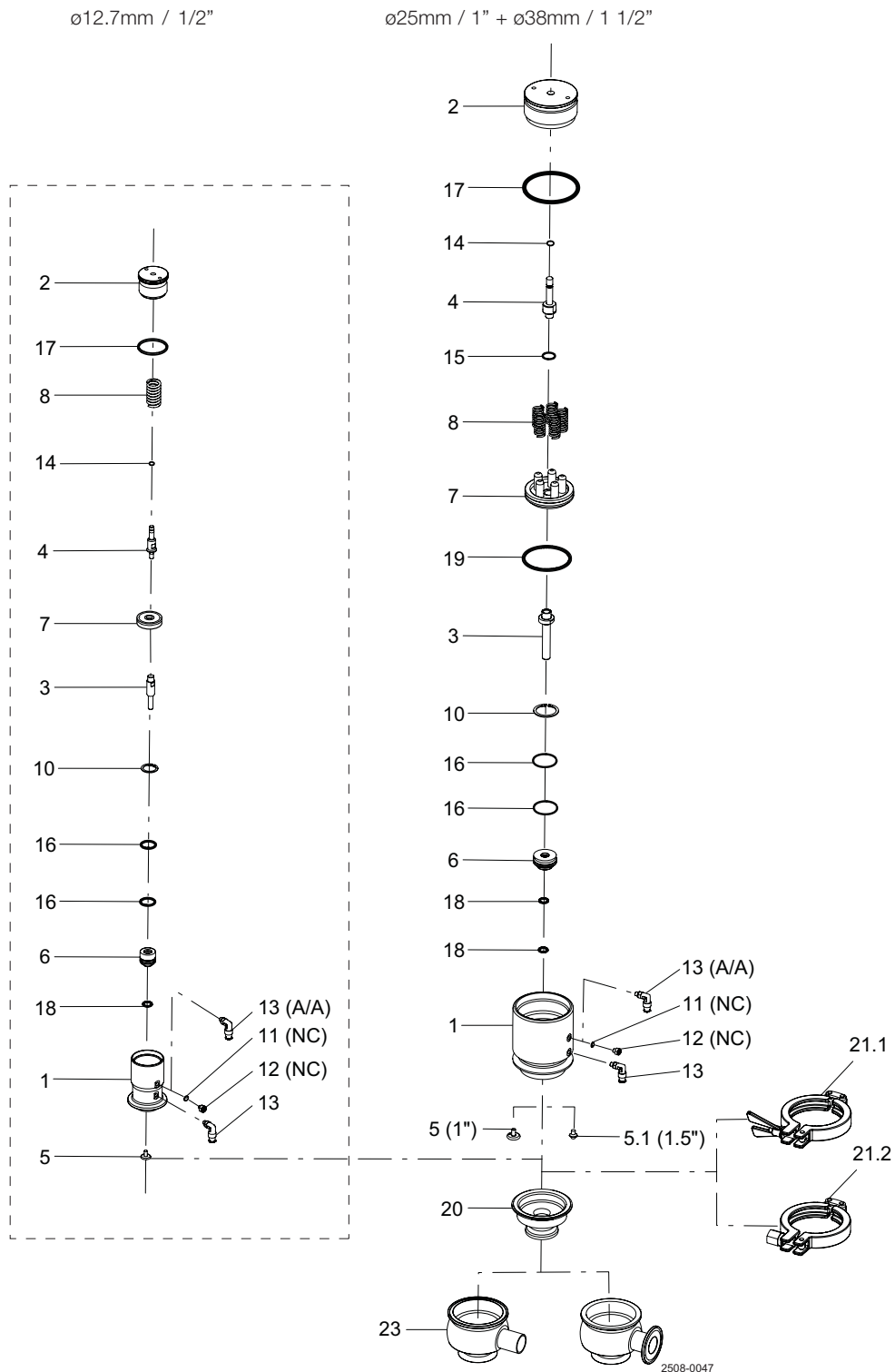



## 7 Parts list and Service Kits

Study the instructions carefully. The items refer to the parts list and service kits section. Handle scrap correctly.

Man = Manually activated

NC = Normally closed.

A/A = Air/air activated.

### Parts list

Pos.	Qty	Denomination
		Actuator, complete (NC)
		Actuator, complete (A/A)
1	1	Actuator housing
2	1	Lid
3	1	Rod
4	1	Indicator rod
5	1	Pressure plate
5.1	1	Threaded insert
6	1	Bushing
7	1	Piston
8	1	Spring (NC)
	5	Spring (NC)
10	1	Clip
11 □	1	Seal
12	1	Air silencer (NC)
13	1	Air fitting (NC)
	2	Air fitting (A/A)
14 □	1	O-ring
15 □	1	O-ring
16 □	2	O-ring
17 □	1	O-ring
18 □	1	X-ring
□	2	X-ring
19 □	1	X-ring
20 ♦	1	Diaphragm, Silicone (incl. Q-doc.)
♦	1	Diaphragm, EPDM (incl. Q-doc.)
21.1	1	Clamp with wing nut
21.2	1	Clamp with hex nut
23	1	Valve body, 2 ports, clamp ends/clamp ends
	1	Valve body, 3 ports, clamp ends/clamp ends
	1	Valve body, 2 ports, welding ends/clamp ends
	1	Valve body, 3 ports, welding ends/clamp ends
	1	Valve body, 2 ports, clamp ends/clamp ends
	1	Valve body, 3 ports, clamp ends/clamp ends
	1	Valve body, 2 ports, welding ends/clamp ends
	1	Valve body, 3 ports, welding ends/clamp ends

### Service kits

Denomination	ø12.7mm 1/2"	ø25mm 1"	ø38mm 1 1/2"
--------------	-----------------	-------------	-----------------

#### Recommended spare parts:

□	Service Kit, actuator .....	9611-92-4306	9611-92-4307	9611-92-4308
♦	Diaphragm, EPDM (incl. Q-doc) .....	9614-0989-01	9614-0989-03	9614-0989-05
♦	Diaphragm, Silicone (incl. Q-doc) .....	9614-0989-02	9614-0989-04	9614-0989-06

## 7 Parts list and Service Kits

Study the instructions carefully. The items refer to the parts list and service kits section. Handle scrap correctly.

Man = Manually activated

NC = Normally closed.

A/A = Air/air activated.

### 7.2 Radial Diaphragm Valve UltraPure - Shut off - Manual

ø12.7mm / 1/2"

ø25mm / 1" + ø38mm / 1 1/2"

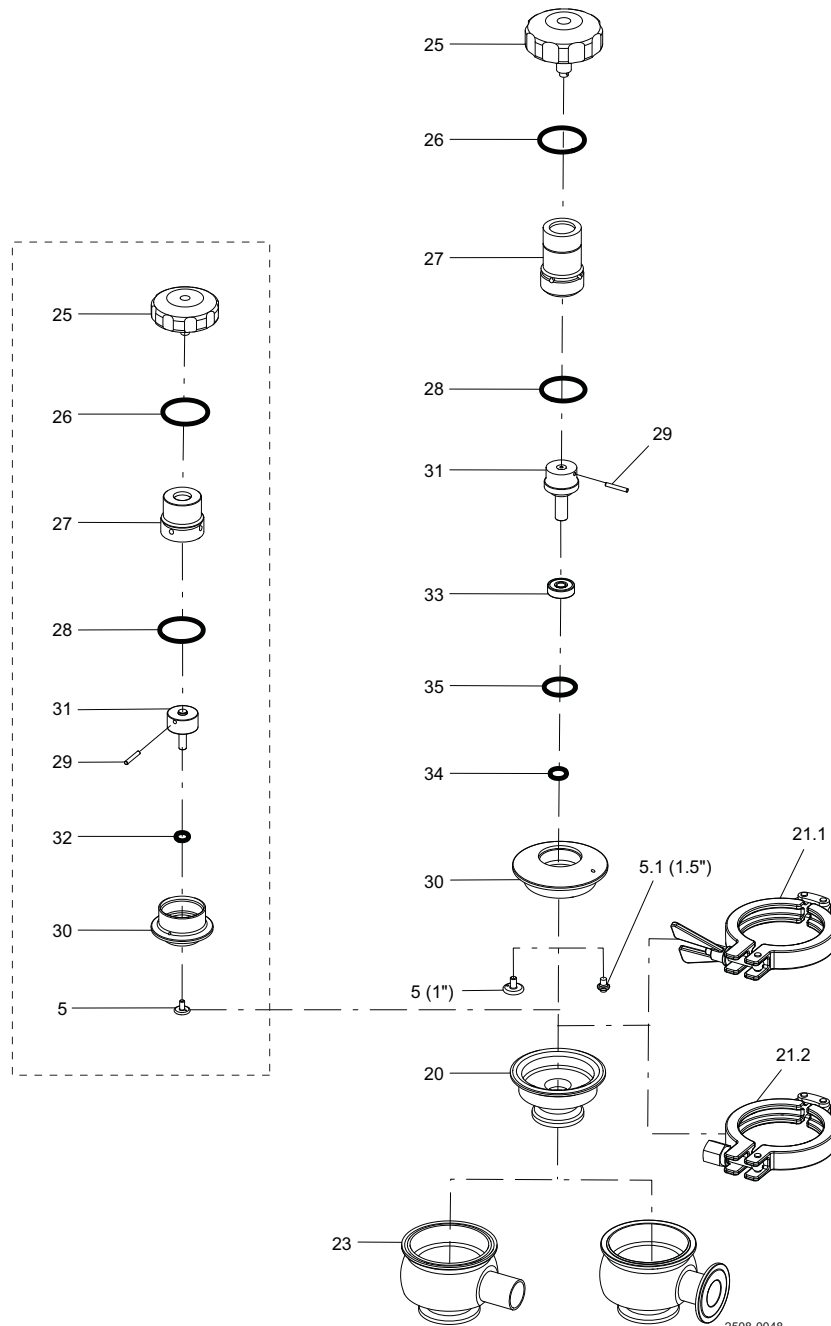

## 7 Parts list and Service Kits

*Study the instructions carefully. The items refer to the parts list and service kits section. Handle scrap correctly.*

*Man = Manually activated*

*NC = Normally closed.*

*A/A = Air/air activated.*

### Parts list

Pos.	Qty	Denomination
5	1	Manual handle, complete
	1	Pressure plate
5.1	1	Threaded insert
20 ♦	1	Diaphragm, Silicone (incl. Q-doc.)
♦	1	Diaphragm, EPDM (incl. Q-doc.)
21.1	1	Clamp with wing nut
21.2	1	Clamp with hex nut
23	1	Valve body, 2 ports, clamp ends/clamp ends
	1	Valve body, 3 ports, clamp ends/clamp ends
	1	Valve body, 2 ports, welding ends/clamp ends
	1	Valve body, 3 ports, welding ends/clamp ends
	1	Valve body, 2 ports, clamp ends/clamp ends
	1	Valve body, 3 ports, clamp ends/clamp ends
	1	Valve body, 2 ports, welding ends/clamp ends
	1	Valve body, 3 ports, welding ends/clamp ends
25	1	Handle
26	1	O-ring
27	1	Housing
28	1	O-ring
29	1	Spring pin
30	1	Flange
31	1	Rod with bearing
32	1	O-ring
33	1	Bushing
34	1	O-ring
35	1	O-ring

### Service kits

Denomination	ø12.7mm 1/2"	ø25mm 1"	ø38mm 1 1/2"
--------------	-----------------	-------------	-----------------

#### Recommended spare parts:

♦ Diaphragm, EPDM (incl. Q-doc) .....	9614-0989-01	9614-0989-03	9614-0989-05
♦ Diaphragm, Silicone (incl. Q-doc) .....	9614-0989-02	9614-0989-04	9614-0989-06

## 7 Parts list and Service Kits

Study the instructions carefully. The items refer to the parts list and service kits section. Handle scrap correctly.

Man = Manually activated

NC = Normally closed.

A/A = Air/air activated.

### 7.3 Radial Diaphragm Valve UltraPure - Tank Outlet - Actuator

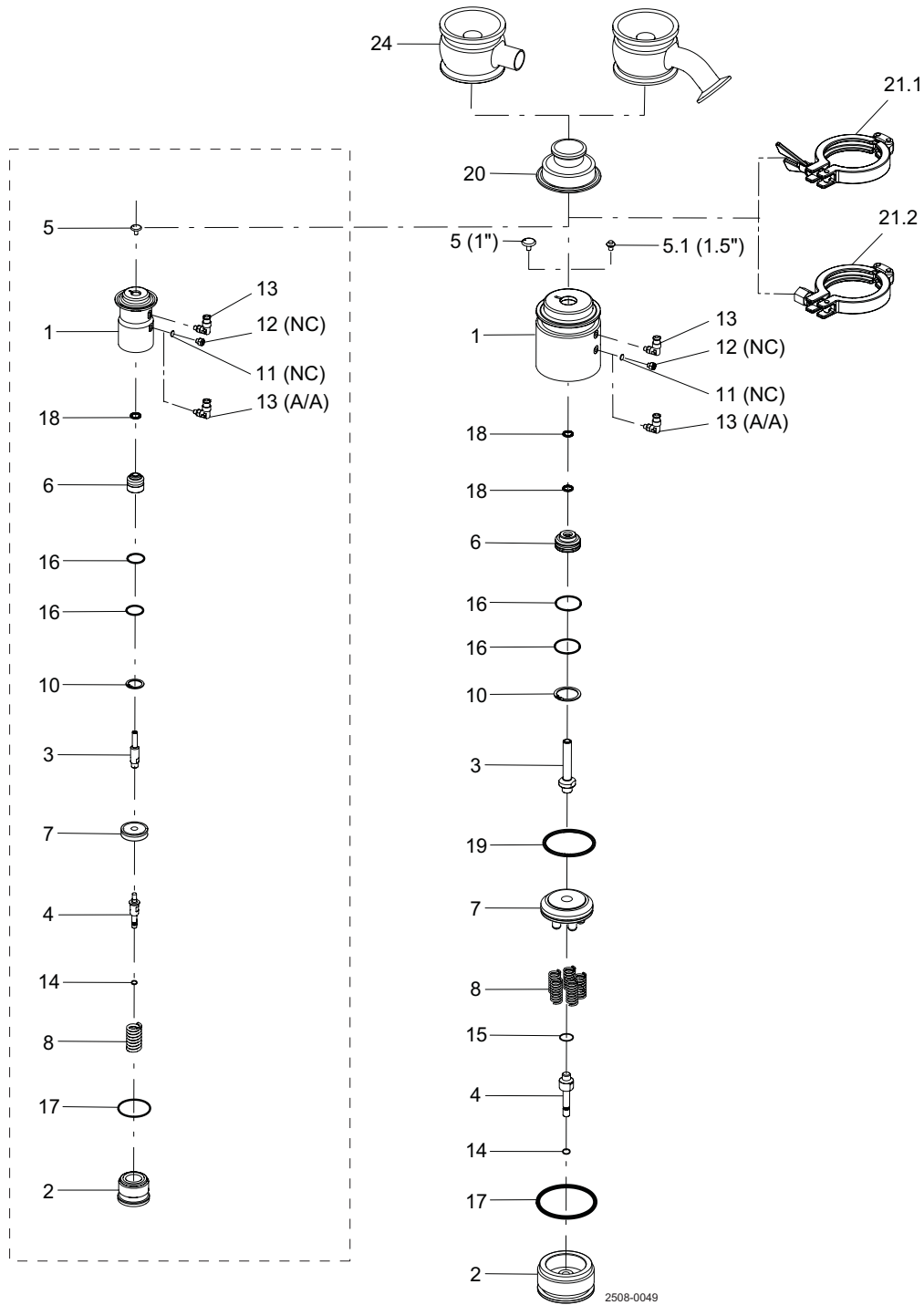

ø12.7mm / 1/2"

ø25mm / 1" + ø38mm / 1 1/2"

## 7 Parts list and Service Kits

Study the instructions carefully. The items refer to the parts list and service kits section. Handle scrap correctly.

Man = Manually activated

NC = Normally closed.

A/A = Air/air activated.

### Parts list

Pos.	Qty	Denomination
		Actuator, complete (NC)
		Actuator, complete (A/A)
1	1	Actuator housing
2	1	Lid
3	1	Rod
4	1	Indicator rod
5	1	Pressure plate
5.1	1	Threaded insert
6	1	Bushing
7	1	Piston
8	1	Spring (NC)
	5	Spring (NC)
10	1	Clip
11 □	1	Seal
12	1	Air silencer (NC)
13	1	Air fitting (NC)
	2	Air fitting (A/A)
14 □	1	O-ring
15 □	1	O-ring
16 □	2	O-ring
17 □	1	O-ring
18 □	1	X-ring
□	2	X-ring
19 □	1	X-ring
20 ♦	1	Diaphragm, Silicone (incl. Q-doc.)
♦	1	Diaphragm, EPDM (incl. Q-doc.)
21.1	1	Clamp with wing nut
21.2	1	Clamp with hex nut
24	1	Valve body, 1 ports, clamp ends/clamp ends
	1	Valve body, 2 ports, clamp ends/clamp ends
	1	Valve body, 1 ports, welding ends/clamp ends
	1	Valve body, 2 ports, welding ends/clamp ends
	1	Valve body, 1 ports, clamp ends/clamp ends
	1	Valve body, 2 ports, clamp ends/clamp ends
	1	Valve body, 1 ports, welding ends/clamp ends
	1	Valve body, 2 ports, welding ends/clamp ends

### Service kits

Denomination	ø12.7mm 1/2"	ø25mm 1"	ø38mm 1 1/2"
--------------	-----------------	-------------	-----------------

#### Recommended spare parts:

□	Service Kit, actuator .....	9611-92-4306	9611-92-4307	9611-92-4308
♦	Diaphragm, EPDM (incl. Q-doc) .....	9614-0989-01	9614-0989-03	9614-0989-05
♦	Diaphragm, Silicone (incl. Q-doc) .....	9614-0989-02	9614-0989-04	9614-0989-06

## 7 Parts list and Service Kits

Study the instructions carefully. The items refer to the parts list and service kits section. Handle scrap correctly.

Man = Manually activated

NC = Normally closed.

A/A = Air/air activated.

### 7.4 Radial Diaphragm Valve UltraPure - Tank Outlet - Manual

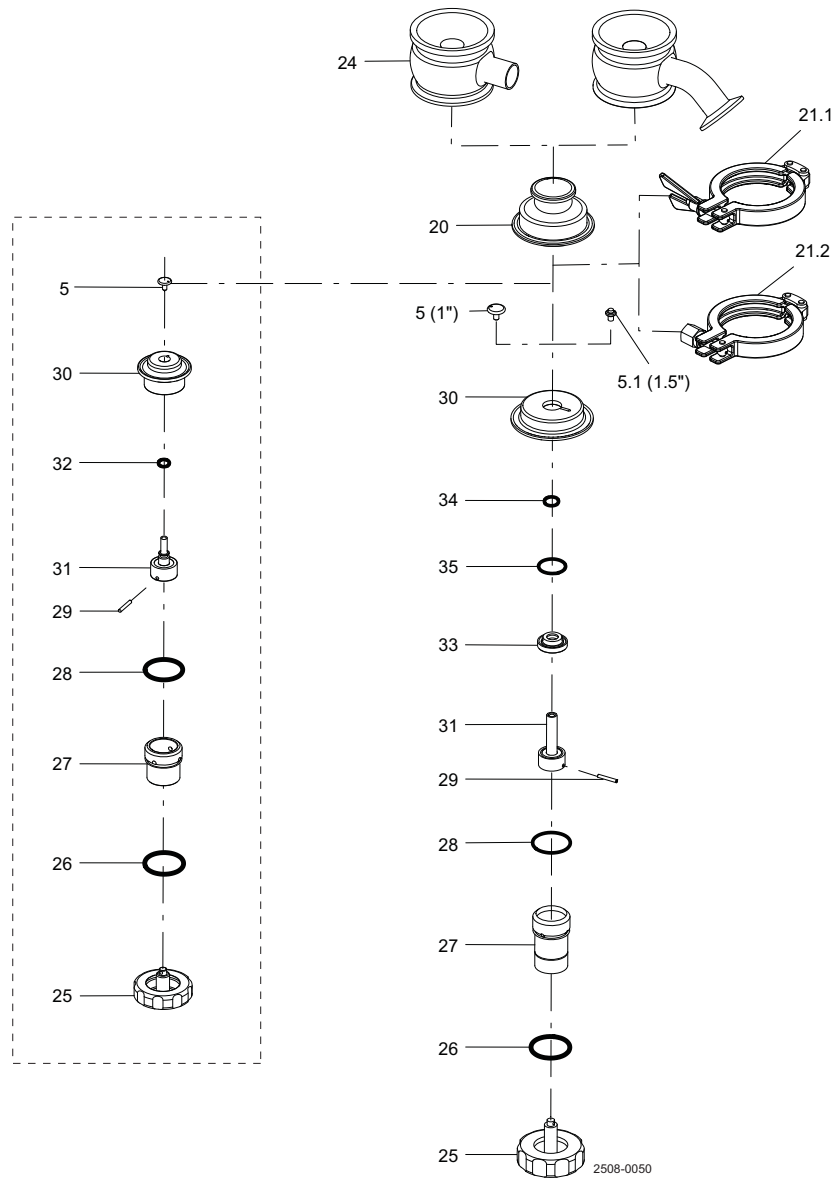

ø12.7mm / 1/2"

ø25mm / 1" + ø38mm / 1 1/2"

## 7 Parts list and Service Kits

Study the instructions carefully. The items refer to the parts list and service kits section. Handle scrap correctly.

Man = Manually activated

NC = Normally closed.

A/A = Air/air activated.

### Parts list

Pos.	Qty	Denomination
5	1	Manual handle, complete
	1	Pressure plate
5.1	1	Threaded insert
20 ♦	1	Diaphragm, Silicone (incl. Q-doc.)
♦	1	Diaphragm, EPDM (incl. Q-doc.)
21.1	1	Clamp with wing nut
21.2	1	Clamp with hex nut
24	1	Valve body, 1 ports, clamp ends/clamp ends
	1	Valve body, 2 ports, clamp ends/clamp ends
	1	Valve body, 1 ports, welding ends/clamp ends
	1	Valve body, 2 ports, welding ends/clamp ends
	1	Valve body, 1 ports, clamp ends/clamp ends
	1	Valve body, 2 ports, clamp ends/clamp ends
	1	Valve body, 1 ports, welding ends/clamp ends
	1	Valve body, 2 ports, welding ends/clamp ends
25	1	Handle
26	1	O-ring
27	1	Housing
28	1	O-ring
29	1	Spring pin
30	1	Flange
31	1	Rod with bearing
32	1	O-ring
33	1	Bushing
34	1	O-ring
35	1	O-ring

### Service kits

Denomination	ø12.7mm 1/2"	ø25mm 1"	ø38mm 1 1/2"
--------------	-----------------	-------------	-----------------

#### Recommended spare parts:

♦ Diaphragm, EPDM (incl. Q-doc) .....	9614-0989-01	9614-0989-03	9614-0989-05
♦ Diaphragm, Silicone (incl. Q-doc) .....	9614-0989-02	9614-0989-04	9614-0989-06

**How to contact Alfa Laval**

Contact details for all countries are continually updated on our website.

Please visit [www.alfalaval.com](http://www.alfalaval.com) to access the information directly.

© Alfa Laval Corporate AB

This document and its contents is owned by Alfa Laval Corporate AB and protected by laws governing intellectual property and thereto related rights. It is the responsibility of the user of this document to comply with all applicable intellectual property laws. Without limiting any rights related to this document, no part of this document may be copied, reproduced or transmitted in any form or by any means (electronic, mechanical, photocopying, recording, or otherwise), or for any purpose, without the expressed permission of Alfa Laval Corporate AB. Alfa Laval Corporate AB will enforce its rights related to this document to the fullest extent of the law, including the seeking of criminal prosecution.