



Instruction Manual, Alfa Laval Hybrid Powder Mixer HPM-M15 & HPM-S15

With

- Standard

IM-TE91A920-EN2

ESE02460EN

Date of issue: Apr. 11, 2014

First published: Nov. 15, 2013

Original manual

The designated company

Alfa Laval Kolding A/S

Company name

Albuen 31, 6000 Kolding, Denmark

Address

+45 79 32 20 00

Phone no.

hereby declare that

Hybrid Powder Mixer

Denomination

AL-HPM-M15 & AL-HPM-S15

Type

is in conformity with the following regulations and directives with amendments:

- Machinery Directive 2006/42/EC
- Regulation (EC) No. 1935/2004 and Regulation (EC) No. 10/2011
- Low Voltage Directive (LVD) 2006/96/EF Directive 2006/95/EC on low voltage
- EMC Directive 2004/108/EF
- ROHS Directive 2002/95/EEC

The technical construction file is retained at the above address.

R&D Manager

Title

Henrik Falster Hansen

Name

Signature

April 7, 2014

Date

Alfa Laval Kolding A/S

Company



Contents

Product programme	4
Standard	4
For your safety	5
General hazards	5
Intended use of the machine	5
Protective measures	5
Specific safety instructions and the symbols used	6
General safety instructions	7
Basic safety measures during normal operation	7
Basic safety measures during maintenance, repair and cleaning	9
Working on the electrical equipment	11
Working on the flush tank	11
Observe the environmental protection instructions	12
Residual risks	12
Function description	13
Construction of the AL HPM	13
Setting up and installation	17
Unpacking and setting up	17
Connecting the product pipes	17
Flush tank and axial face seal	17
Power supply	18
Commissioning	19
Connecting the AL HPM to a mixing tank	19
Brief test	20
Information on working with products	20
Powering up the machine	21
Cleaning and maintenance	22
Cleaning (CIP)	22
The axial face seal	22
C-Ball Valve	22
Rotor/Stator	22
Barrier fluid installation	23
Drive	23
Installation and removal	24
Rotor/Stator	24
Installing the drive	24
Technical data	25
Operational data	27
Technical data	27
Dimensions/weight	27
Parts and spares list	29
Parts list, Powder Mixer complete, HPM-M15	29
*) Optional, not part of machineParts drawing, Powder Mixer complete, HPM-M15	29
Parts list, Powder Mixer complete, HPM-S15	31
Parts drawing, Powder Mixer complete, HPM-S15	32

Parts list, Base frame, HPM-M15	33
Parts drawing, Base frame, HPM-M15	34
Parts list, Flush container, HPM-M15/HPM-S15	35
Parts drawing, Flush container, HPM-M15/HPM-S15	35
Parts list, C-ball valve, HPM-M15/HPM-S15	36
Parts drawing, C-ball valve, HPM-M15/HPM-S15	36
Parts list, Inlet tube, HPM-M15/HPM-S15	37
Parts drawing, Inlet tube	37
Parts list, Butterfly valve, HPM-M15	38
Parts drawing, Butterfly valve, HPM-M15	38
Parts list, High shear and pump unit, HPM-M15/HPM-S15	39
Parts drawing, High shear and pump unit, HPM-M15/HPM-S15	40
Additional documents	41
General Information	42
Service / Repair	42
Warranty	42
How to contact Alfa Laval	42

© Alfa Laval Corporate AB

This document and its contents is owned by Alfa Laval Corporate AB and protected by laws governing intellectual property and thereto related rights. It is the responsibility of the user of this document to comply with all applicable intellectual property laws. Without limiting any rights related to this document, no part of this document may be copied, reproduced or transmitted in any form or by any means (electronic, mechanical, photocopying, recording, or otherwise), or for any purpose, without the expressed permission of Alfa Laval Corporate AB. Alfa Laval Corporate AB will enforce its rights related to this document to the fullest extent of the law, including the seeking of criminal prosecution.

Product programme

This manual covers the product program for Alfa Laval Hybrid Powder Mixer HPM-M15 and HPM-S15.

Standard

HPM-M15						
Version	Item no.	Motor	Funnel	Inlet	Outlet	Frequency converter, for voltage
US	TE35A001	NEMA TEFC Wash Down (IP66)	40 l	TriClamp	TriClamp	3 Phase 380-480 Vac (±10%) 50-60 Hz
CANADA	TE35A002	NEMA TEFC Wash Down (IP66)	40 l	TriClamp	TriClamp	3 Phase 525-690 Vac (±10%) (Canada) 50-60 Hz
ROW	TE35A000	IEC IP55 + Shroud	40 l	DIN	DIN	3 Phase 380-480 Vac (±10%) 50-60 Hz

HPM-S15						
Version	Item no.	Motor	Funnel	Inlet	Outlet	Motor voltage
US/CAN	9614302801	NEMA TEFC Wash Down (IP66)	40 l	TriClamp	TriClamp	3 Phase 380-480 Vac (±10%) 50-60 Hz
ROW	9614302701	IEC IP55 + Shroud	40 l	DIN	DIN	3 Phase 380-480 Vac (±10%) 50-60 Hz

For your safety

General hazards

The machine is not dangerous in itself, provided that it is used as intended. To prevent injury to people and damage to the machine, it must only be operated as intended. However, the manufacturer is unable to foresee dangers that may result from installing or combining the machine with other machines. The machine operator must observe the safety instructions when operating the machine. The machine may only be operated by authorised, trained operators. The machine may only be commissioned when fully installed.

Intended use of the machine

The machine is used for wetting and dispersing powder in fluids and also for blending fluids in fluids. The machine is suitable for producing products with viscosities up to 500 mPas, based on the viscosity at the powder mixer impeller in the case of Newtonian products.

To protect the mixing tools against damage by foreign objects, e.g. screws, stones, pieces of wood, etc., we recommend the use of suitable measures to prevent such objects from entering the machine. The safety mesh provided is one such measure and should be used at all times. Place the safety mesh in the funnel before introducing the powder.

Protective measures

Operator's duty of care

The machine (including the sub-assemblies) has been designed and built taking into account a risk analysis and after careful selection of harmonised standards and other technical specifications to be observed. It therefore conforms to the state of the art and provides maximum safety in operation.

However, the safety of the machine in practice can only be achieved if all the necessary measures are adopted for this purpose. It is part of the machine operator's duty of care to plan these measures and monitor their implementation.

In particular, the operator must make sure that

- the machine is only used as intended;
- the machine is only operated if it is in perfect working order and, in particular, the functioning of the safety devices is checked regularly;
- the necessary personal protection for operating, maintenance and repair personnel is both available and worn;
- the operating instructions are always legible and complete versions are available at the place where the machine is installed;
- only duly qualified and authorised personnel operates, maintains and repairs and the machine;
- this personnel is instructed regularly in all relevant issues relating to health and safety in the workplace and protection of the environment and is also familiar with the operating instructions and the safety information contained in those instructions;
- safety and warning information on the machine is not removed and it is legible.

Specific safety instructions and the symbols used

The following operating instructions include specific safety information that refers to unavoidable residual risks when operating and maintaining the machine. The residual risks include risks for:

- people
- product and machine
- the environment.

The symbols used in the operating instructions must draw attention to the safety instructions in particular.

Warning

This symbol means that personal danger in particular is to be expected. (danger to life, risk of injury).



Danger!

Warning

This symbol means that danger is to be expected in particular for machine, material and the environment.



Caution!

Note: This symbol is not a safety instruction, but provides information to allow a better understanding of the machine operations.

General safety instructions

Warning Changes may only be made to the installation or parts of it subject to the written consent of ALFA LAVAL, otherwise, the warranty and declaration of conformity will lapse.



Warning The machine is live when the power supply is connected. This voltage can have life-endangering effects on contact.



We reserve the right to make technical changes.

Basic safety measures during normal operation

Warning Before switching on the machine, make sure you know what to do in the event of an incident.



Warning The machine may only be operated by qualified, authorised personnel, who are familiar with the operating instructions (including those for the sub-assemblies) and are able to work accordingly!



Warning Replace all hoses regularly as a preventive maintenance measure, even if not obviously damaged). (Observe the manufacturers' information)



Warning If components of the installation are temperature-controlled, there is a risk that parts not insulated and supply lines may catch fire above a temperature of 65°C. In this case, the operator must protect the hot parts against contact.



Warning If water is used as a barrier medium, it must be cooled at temperatures above 85°C, otherwise, the seal may be damaged.



Note: Check the level (sight glass) of the flush tank every day. If the axial face seal is flushed with fresh water, make sure the flow volume is sufficient (0.25-0.5 l/min.).

Note: The machine may not be commissioned (even briefly) if the barrier medium circuit is not intact, otherwise the axial face seal may be destroyed.

Note: The machine is not suitable for processing pure dry substances without the use of fluids. This can cause serious damage to the machine.

Note: When changing the dry substance, check whether the materials of the axial face seal and of the O-rings are still compatible. In some cases, it is necessary to change the parts for different materials. If there is any doubt, consult the supplier.

Note: After all the installation work has been completed, the movement of the drive shaft must be checked on the machine by rotating it manually before the drive is switched on. Make sure the drive cannot be switched on accidentally.

Basic safety measures during maintenance, repair and cleaning

Warning



The machine may only be maintained according to the safety instructions by qualified, authorised persons, who are familiar with the operating instructions (and those for the sub-assemblies) and can work accordingly.

Warning



Before maintenance and repair work, switch off the main power supply switch and secure with a padlock. The person carrying out the maintenance or repair work must keep the key to this lock.

Warning



When changing heavy machine parts, only use suitable and safe load handling devices and sling gear.

Warning



Before any maintenance and repair work, make sure that any parts of the machine which may be touched have cooled down to room temperature.

Before any maintenance or repair work, make sure that unauthorised persons cannot access the work area. Attach or set up a sign drawing attention to the maintenance or repair work in progress.

Warning



Observe the inspection and maintenance intervals specified in the operating instructions. Observe the maintenance and repair instructions for sub-assemblies included in these operating instructions.

Warning



Dispose of environmentally hazardous lubricants, coolants or cleansing agents in a responsible manner.

Note: After all the installation work has been completed, the movement of the drive shaft must be checked on the machine by rotating it manually before the drive is switched on. Make sure the drive cannot be switched on accidentally.

Note: The rotor shaft nut must be tightened by hand and then with a torque wrench (tightening torque approximately 30 Nm). It is also advisable to lock the thread with a liquid thread lock, such as Loctite, for example.

Note: Any work on the axial face seal must be done very carefully. The seals consist of a brittle material and are therefore sensitive to shocks. Avoid impact.

Warning



The cleaning (CIP) of the powder mixer is carried out in combination with the cleaning of the tank or when cleaning the pipe system of the entire installation. The funnel and the ball valve must be removed and replaced by the blind flange supplied. This guarantees that no CIP fluid, such as soda lye or acid, for example, will leak out if the ball valve is opened accidentally.

Working on the electrical equipment

Note: Switch on briefly to check whether the motor is rotating in the direction indicated (arrow on the pump housing).

Note: The machine connection must comply with VDE standards.

When the motor is connected to the power supply, check that the motor voltage, frequency converter and mains voltage correspond.

The voltages are indicated on the motor rating plate or the frequency converter data sheet.

Warning



Only qualified electricians may repair the machine's electrical equipment.
Check the electrical equipment regularly.
Re-tighten any loose connections.
Replace damaged lines/cables immediately.
Keep the frequency converter locked and clean at all times!
Only authorised persons with key/tool are allowed access.
Never hose down a frequency converter to clean it.

Working on the flush tank

Warning



The machine must not be commissioned (even briefly) if the barrier medium circuit is not intact, otherwise the axial face seal may be destroyed.

Check that screw connections are firmly tightened after any maintenance or repair work.

After completion of the maintenance or repair work, and before resuming production, make sure that all the materials, tools and other equipment required for carrying out the maintenance or repair work are removed from the work area of the installation and that all the installation's safety devices are functioning properly.

Observe the environmental protection instructions

Warning



The legal obligations relating to the prevention of waste and recycling/disposal must be observed whenever work is done on and with the machine. Particularly when installation, repair and maintenance work is performed, water-hazardous substances, such as:

- lubricating grease and oil
- hydraulic fluids
- coolants
- solvent-containing cleaning fluids

do not contaminate the soil or enter the drains.

These substances must be stored, transported, collected and disposed of in suitable tanks.

Residual risks

The machine has been designed so that the machine itself and its accessories cannot cause any risks for people, products and the environment. The operating instructions have been written so that no risks arise when observing warning signs and maintenance specifications.

However, it cannot be ruled out that risks may occur as the result of human error.

No further risks are to be expected if the equipment is used correctly and the recommendations and instructions according to the accident prevention regulations (UVV) and the occupational insurance associations are observed.

Function description

The Alfa Laval Hybrid Powder Mixer (AL HPM) is a combination of two technologies (powder mixer and pump) and is mainly used to disperse solids (power or crystals) in fluids. Because of the high pressure that the HPM can generate, even during powder intake (up to 4 bar), it can also be used as a mobile feed or discharge pump or as a CIP pump.

The powder to be mixed is delivered to the HPM via the funnel (item 1 in Figure 1) and homogenised or dispersed in the fluid flow with the aid of a rotor-stator system in the first stage (item 2 in Figure 1). In the second stage, the mixture is then discharged from the equipment with the aid of the impeller (item 3 in Figure 1). During this process, a product sub-flow is recirculated via a second (smaller) connection (item 4 in Figure 1). This sub-flow is introduced into the injector (item 5 in Figure 1). This generates a negative pressure at the funnel outlet, which in turn allows the powder to be drawn in. NOTE: The function is the same on the stationary HPM-S15 version shown on figure 2.

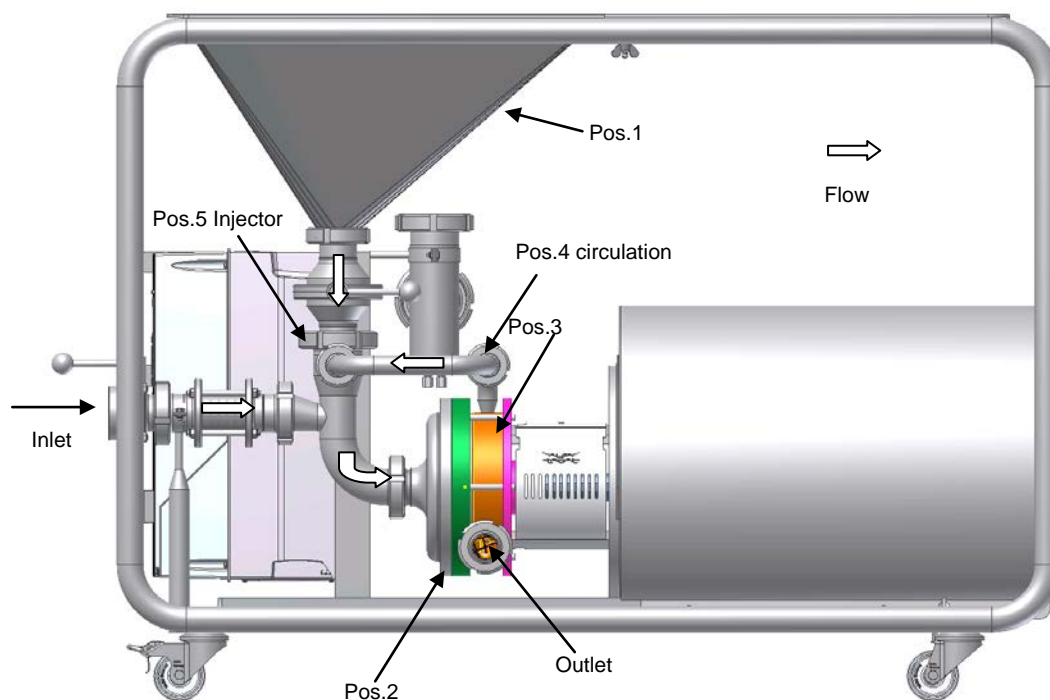

Figure 1

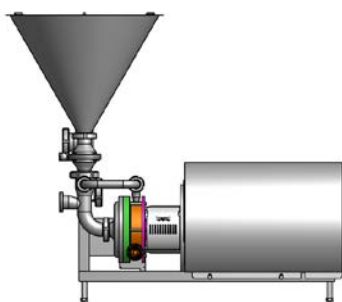

Figure 2

Construction of the AL HPM

The equipment consists of the following units:

- frequency converter (Only HPM-M15)
- drive
- axial face seal
- injector
- rotor/stator, stage 1
- pump impeller, stage 2
- sight glass (Only HPM-M15)
- funnel and top plate (Top plate only HPM-M15)
- Frame with wheels (Only HPM-M15)



Figure 3, HPM-M15



Figure 4, HPM-S15

Frequency converter (Only on HPM-M15)

The frequency converter used is the Danfoss FC 300. Details of the frequency converter are given in the separate operating instructions from Danfoss.

Drive

The power is transmitted from the electric motor to the drive shaft via a three-phase motor. Details of the drive are included in the separate operating instructions for the multi-stage centrifugal pump LKH-112.

Axial face seal

Details of the axial face seal are included in the separate operating instructions for the multi-stage centrifugal pump LKH-112.

Injector

The injector allows the powder to be drawn into the fluid and generates the preliminary mixing of the two components. It consists of a removable housing with a central suction pipe through which the component from the funnel is blended. The sub-flow from the second stage of the pump serves as the propellant medium for the injector, which is made possible via the small recirculation pipe (see Figure 5).

NOTE: HPM-S15 is supplied WITHOUT inlet valve.

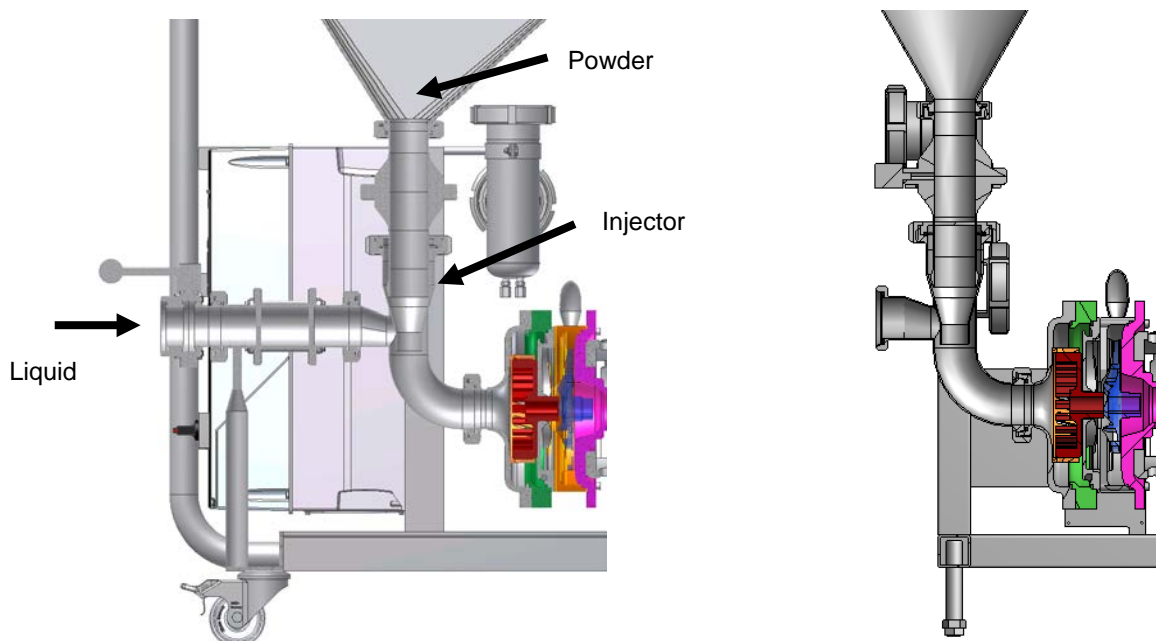

Figure 5

Rotor/stator, stage 1

The rotor/stator system is located on the drive shaft, upline of the pump impeller and downline of the injector. The main job of the rotor/stator is to disperse the powder in the fluid.

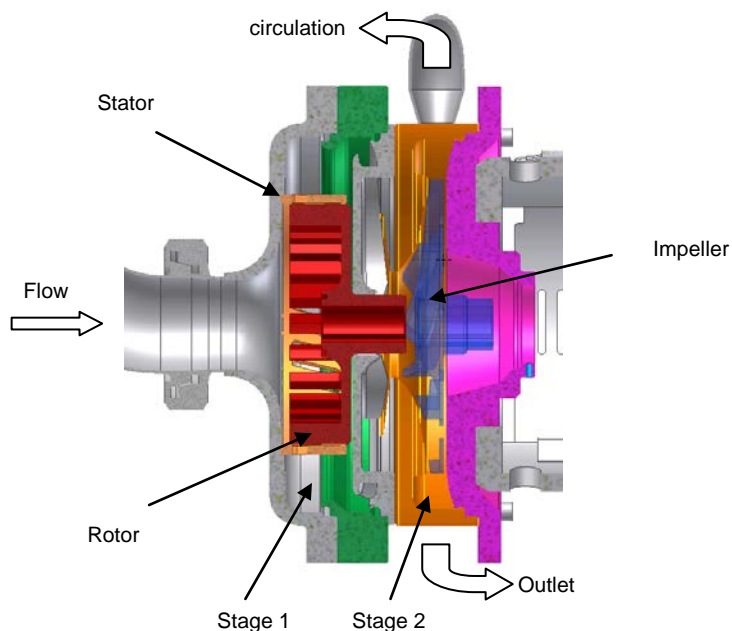

Figure 6

Pump impeller, stage 2

The impeller is located on the drive shaft downline of the rotor/stator. The main job of the impeller is to deliver the powder/fluid mixture back to the tank at high pressure and deliver a sub-flow back to the injector via the circulation pipe (see Figure 6).

Sight glass (Only HPM-M15)

The sight glass is located in the HPM supply and is used to observe the fluid flow visually.

Funnel and cover plate (Cover plate only HPM-M15)

The funnel consists of two parts: the funnel itself, into which the powder is delivered, and the funnel cover plate, which is mainly used as a support surface for the product. After cleaning, the cover plate is placed on the funnel and therefore protects it from pollution in the funnel room outside operating hours.

Frame (Only HPM-M15)

The modular frame is made from easy to clean tubing and allows safe and easy handling of the HPM. The frame stands on rollers, the complete system is mobile.

Setting up and installation

Unpacking and setting up

When unpacking, check all parts for damage in transit. Damaged parts must not be used. In the event of any damage, notify the transport company and relevant transport insurance company immediately.

A suitably qualified member of staff must unpack, clean and assemble the machine in accordance with the installation instructions.

Goods must be stored and transported in the original packing. Avoid any loading or mechanical stress, in particular of housings, shafts, bearing points, through foreign objects or inadmissible vibration. Goods may only be transported on the load handling equipment provided for this purpose.

The machine must be set up safely on the floor so that it is easily accessible.

The machine must not be exposed to any heat radiation or technical magnetic fields. No stands for people or other heavy objects may be attached to the machine. The machine must not be set up in traffic areas. It must be accessible for maintenance and operation at all times.

Install the machine as near to the production tank as possible.

Lock the rollers to prevent uncontrolled movement of the machine.

Connecting the product pipes

The product inlet and outlet must be firmly and tightly connected to the tank's circulation pipe (see Figure 7). Keep the product inlet pipe (intake pipe) as short as possible and do not use a diameter smaller than the connection of the unit. Use bigger diameters for increased viscosity in order to reduce the pressure drop on the suction side.

Flush tank and axial face seal

The flush tank and axial face seal can be operated in two ways:

- I. Closed-circuit type with a defined volume of barrier fluid
- II. Flushed type, where fresh water flows through the axial face seal and then into the gully (0.25-0.5 L/minute).

In order to guarantee the necessary circulation of the barrier medium through the axial face seal, the hoses have to be correctly connected to the barrier medium tank.

The barrier medium used should have the following characteristics:

- low viscosity (similar to water, approximately 1 mPas)
- good lubrication capability
- good thermal conductivity
- product neutrality

Water with a 5% addition of glycerine or glycol is used as the barrier medium as standard.

The barrier fluid should reach the middle of the sight glass. At this level, the fill corresponds to approximately 0.7 litres. It only usually has to be replaced if it becomes polluted.

After filling, the circuit and the axial face seal in particular should be vented. To do this, undo the return hose on the flush tank and wait until fluid emerges. Then tighten again.

Power supply

Since no dangerous movements are accessible on the machine, no emergency stop has been provided.

The machine connection must comply with VDE standards. When the motor is connected to the power supply, check that the motor voltage, frequency converter and mains voltage correspond.

The motor voltage is indicated on the motor rating plate or the frequency converter data sheet. Details of the frequency converter are given in the attached operating instructions for the frequency converter.

Commissioning

The operator must observe VDE standard 0530 when commissioning the machine.

The machine may only be operated by trained, authorised operating personnel. Never commission the machine if it is not fully installed.

Before commissioning, remove all dirt and foreign objects from the machine and the connected pipes and tanks. Check that machine rotor and stator are running freely and free from contact.

Connecting the AL HPM to a mixing tank

Before commissioning, the AL HPM must be permanently piped to a tank in which the powder solution is produced (see Figure 7, circulation pipe). Hoses approved for the operation may also be used.

Make sure that during operation, ideally, a back-pressure of approximately 2 bar is generated after the outlet of the HPM to allow optimum powder intake (1 bar would also be possible). This can be achieved with the aid of an Isomix jet mixer (see Figure 7) installed in the tank at the end of the circulation pipe. This has the advantage that optimum intermixing is achieved inside the tank.

After mixing, the Isomix rotating jet mixer can also be used to clean the tank (CIP).

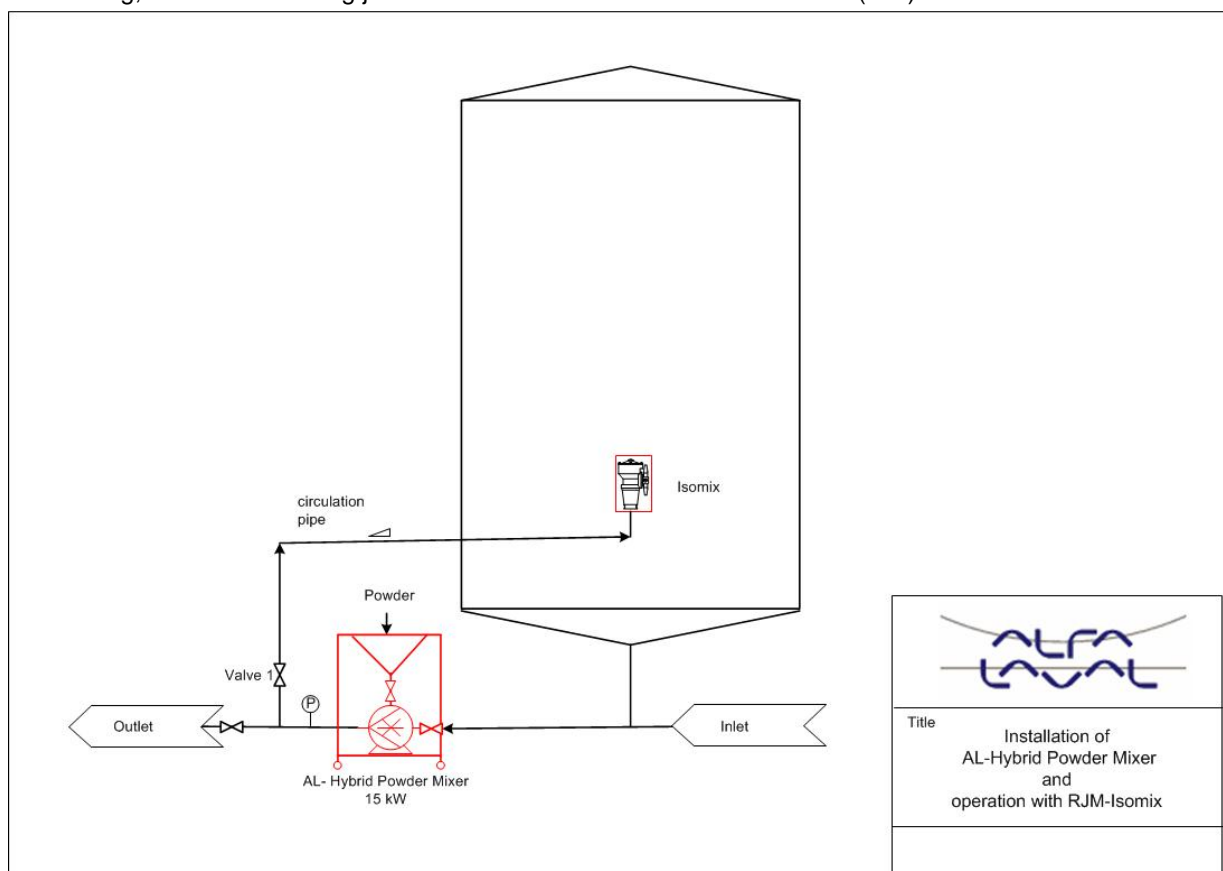

Figure 7

If there is no Isomix to generate the back-pressure, a simple manual valve (see Figure 7, valve 1), which is connected after the HPM and serves as a throttle, can be used. We recommend that a pressure gauge is always provided after the HPM in order to check the back-pressure generated.

We also recommend positioning the HPM inlet at least 200 mm lower than the tank outlet so that the fluid can flow freely into the mixer. The circulation pipe return should be piped so that no air pockets can form in the pipes. The highest point should be the Isomix or the product inlet in the tank (see Figure 7).

When connecting permanent pipes, it is also advisable to include a compensator in the pipe in some circumstances.

The barrier medium circuit must be filled with a suitable medium before commissioning the machine for the first time (see page 17, Flush tank and axial face seal)

The machine may not be commissioned (even briefly) if the barrier medium circuit is not intact, otherwise the axial face seal may be destroyed.

Brief test

Check the following again with a short trial run:

1. contamination in the funnel
2. set the valve on the funnel outlet to the closed position
3. the direction of rotation of the motor
4. the fluid level in the flush tank
5. check for any unusual mechanical noises.

Information on working with products

The AL HPM has been designed in particular for mixing solids and fluids. However, the following things also need to be taken into account to work with the machine successfully:

Warning

Powders difficult to dissolve or those that swell extensively and have a tendency to stick may only be added in very small quantities, because otherwise the machine may become clogged. Always turn on the ball valve under the funnel slowly and check the intake behaviour at the same time.

Warning

Never deposit BIG bags on the modular frame because their weight may damage it.

Powering up the machine

A minimum fluid volume is required for the machine to function and this has to be introduced into the mixing tank.

Please perform the following operations in the order listed when commissioning the machine:

- close the ball valve underneath the funnel.
- open all the valves in the circulation pipe.
- check via the sight glass in the machine inlet whether the fluid is flowing into the machine automatically. If it is, wait until the pipe fills.
- Switch the machine on via the frequency converter and pump the fluid in the circuit.
- With the frequency converter, increase the frequency to 60 Hz (see the frequency converter operating instructions).
- If there is no Isomix mixer in the mixing tank, it must be ensured that a back-pressure of approximately 2 bar is built up by throttling the valve downline of the HPM. Since the valve and the pressure gauge are not part of the supply, the operator has to install these components.
- Insert the safety mesh in the funnel.
- Introduce powder into the funnel.
- Slowly open the ball valve underneath the funnel.
- With hardly soluble powders, the ball valve should only be opened 10%-15%.
- With easily soluble powders, the ball valve may be opened 100%.
- Make sure that during the powder intake, no air pockets form in the powder, as otherwise, air can be entrained into the system. Air pockets should be avoided and any that occur should be dislodged immediately (manually).
- After the powder has been drawn in, close the ball valve immediately and only open it again when powder is next added. Never aspirate air into the system.
- Since the suction power is reduced with increasing viscosity, make sure that the maximum viscosity of 500 cP in the mixer is not exceeded. (500 cP in the case of Newtonian products).

Cleaning and maintenance

Cleaning (CIP)

The unit has to be cleaned regularly, depending on the type of operation. Dirt in the pipes and chambers can lead to contamination and therefore pollution of the product (when next commissioned).

The cleaning (CIP) of the machine is carried out in combination with the cleaning of the tank or when cleaning the pipe system of the entire installation.

The funnel and the ball valve, which should be cleaned manually, have to be removed and replaced by the blind flange supplied. This guarantees that no CIP fluid, such as lye or acid can escape if the ball valve is opened accidentally.

The axial face seal

Details of the maintenance of the axial face seal are included in the attached operating instructions for the multi-stage centrifugal pump LKH.

C-Ball Valve

The PTFE housing of the ball valve should be checked regularly. The operator can decide on the checking intervals himself, because it very much depends on the types of powder used.

Rotor/Stator

The high-seed rotor, and also the stator, react sensitively to foreign objects. Therefore, objects such as, for example, screws, stones, welding beads, etc. must be prevented from entering the machine.

In the case of highly adhesive and curing media, the machine should also be flushed immediately at the end of the operation.

Depending on the abrasiveness of the mixed product, the mixing tools are exposed to a certain amount of wear. Since the size of the shear gap can affect the mixing quality, the tools need to be checked for wear from time to time. The operator can decide on the checking intervals himself, because it very much depends on the types of powder used.

Barrier fluid installation

Daily fluid level check.

Occasional check of the leak-tightness of the hoses, particularly in the area of screw connections.

Drive

Details of the drive are included in the separate operating instructions for the multi-stage centrifugal pump LKH.

Note: Please note that the first step of the pump is modified compared to the standard LKH.

Installation and removal

After all the installation work has been completed, the movement of the drive shaft must be checked on the machine by rotating it manually before the drive is switched on. Make sure the drive cannot be switched on accidentally.

Before any maintenance and repair work, switch off the main power supply switch and lock with a padlock. The person carrying out the maintenance or repair work must hold the key to this lock.

Rotor/Stator

Removal of the Rotor/Stator

1. Isolate the AL HPM from the mains
2. Remove the funnel and cover plate
3. Disconnect supply pipes from solid and fluid pipes.
4. Undo and remove 6 cap nuts from the pump housing
5. Remove the complete pump housing with stator from the machine

Fitting the Rotor/Stator

Fit the tools in the reverse order to their removal:

To make removal easier, first lightly grease the hubs of the tools with a suitable grease.

When fitting, make sure that the O-rings of the individual tools lie correctly in the groove when they are stacked.

Firmly tighten the shaft cap nuts with a torque wrench (tightening torque approximately 30 Nm). We also recommend locking the thread with a liquid thread lock, such as Loctite, for example.

Installing the drive

Details for installing the drive are included in the separate operating instructions for the multi-stage centrifugal pump LKH.

Technical data

HPM-M15	ROW version	US version	CANADA version
Motor			
Type:	(Incl. SS motor shroud): Standard foot-flanged motor with a fixed ball bearing on drive side, according to IEC metric standard, 2 poles = 3000/3600 RPM at 50/60 Hz, enclosure IP55 (with drain hole with labyrinth plug), insulation class F.	Standard-C Face/Foot mounted NEMA motor with a fixed ball bearing on drive side, according to NEMA standard, 2 poles = 3600 RPM at 60 Hz, enclosure TEFC Wash Down.	Standard-C Face/Foot mounted NEMA motor with a fixed ball bearing on drive side, according to NEMA standard, 2 poles = 3600 RPM at 60 Hz, enclosure TEFC Wash Down
Mains option:		Local mains disconnect	
Insulation class:		IP66/NEMA 4X	
Display		Graphical local control panel	
Power			
Installed power		18.5 kW / 25 hp	
Frequency drive			
Type:		Danfoss VLT® AutomationDrive FC 300 series	
Power rating:		18.5 kW / 25 hp (Normal overload 110 %/60 s)	
Input voltage	380-480 VAC	380-480 VAC	525-600 VAC
RFI filter:	Class A1/B	Class A1/B	No filter
Materials			
Product wetted steel parts:		W. 1.4404 (316L) and Duplex steel	
Other steel parts:		W. 1.4301 (304)	
Product wetted seals:		EPDM, PTFE	
Other O-rings:		EPDM	
Finish		Semi-Bright	
Internal surface roughness:		Pipework acc. to DIN11850 Ra<0.8 µm (Impellers: Blasted/machined)	
Shaft seal:		Single mechanical SiC/SiC, flushed version	
Flush tank		Approx. 1 ltr. incl. sight glass. Note: Flush through possible via easy connection	
Connections			
Liquid inlet connection:	DIN 11851 DN 50 male union	TriClamp 2"	TriClamp 2"
Liquid outlet connection:	DIN 11851 DN 40 male union	TriClamp 1½"	TriClamp 1½"
Control of powder addition			
		Manually actuated special C-Ball valve for dry ingredient adding	
Other:			
		Blind cover at powder inlet for use during CIP	

HPM-S15	ROW version	US/CANADA version
Motor		
Type:	(Incl. SS motor shroud): Standard foot-flanged motor with a fixed ball bearing on drive side, according to IEC metric standard, 2 poles = 3000/3600 RPM at 50/60 Hz, enclosure IP55 (with drain hole with labyrinth plug), insulation class F.	Standard-C Face/Foot mounted NEMA motor with a fixed ball bearing on drive side, according to NEMA standard, 2 poles = 3600 RPM at 60 Hz, enclosure TEFC Wash Down.
Mains option:	Local mains disconnect	
Insulation class:	IP66/NEMA 4X	
Power	15 kW (at 50 Hz) / 20 hp (at 60 Hz)	
Input voltage	380-480 VAC	
Materials		
Product wetted steel parts:	W. 1.4404 (316L) and Duplex steel	
Other steel parts:	W. 1.4301 (304)	
Product wetted seals:	EPDM, PTFE	
Other O-rings:	EPDM	
Finish	Semi-Bright	
Internal surface roughness:	Pipework acc. to DIN11850 Ra<0.8 µm (Impellers: Blasted/machined)	
Shaft seal:	Single mechanical SiC/SiC, flushed version	
Flush tank	Approx. 1 ltr. incl. sight glass. Note: Flush through possible via easy connection	
Connections		
Liquid inlet connection:	DIN 11851 DN 50 male union	TriClamp 2"
Liquid outlet connection:	DIN 11851 DN 40 male union	TriClamp 1½"
Control of powder addition	Manually actuated special C-Ball valve for dry ingredient adding	
Other:	Blind cover at powder inlet for use during CIP	

Operational data

Technical data

Rotor speed (60 Hz)	3,500 rpm.
Maximum admissible product temperature	55°C
Maximum admissible operating overpressure	10 bar
Maximum Throughputs	29 m ³ /h

The values apply to the standard speed of 3,500 rpm., water at 20°C

The throughput drops with increasing viscosity of the mixed product at the same speed.

Temperature range:	-10°C to +95°C
Recommended inlet pressure:	0.0 – 0.2 bar
Min. back pressure recommended:	1 bar
Dry ingredient capacity:	Dependent on powder (e.g. 3000 kg/h capacity for skimmed milk powder)
Noise level (at 1 m):	< 90 dB(A)

Dimensions/weight

	HPM-M15	HPM-S15
HxWxL [mm]:	1130 x 826 x 1340	1115 x 580 x 1300
Weight:	Approx. 280 kg	Approx. 230 kg
Max. table load:	300 kg	-

- Blank -

Parts and spares list

Parts list, Powder Mixer complete, HPM-M15

Pos.	Qty	Part number	Denomination	Material
1	1	On request	Table plate/Funnel	1.4301
2	1	On request	Safety mesh	1.4301
3	1	Assy, see page 33	Base frame, complete	1.4301
4	2	Assy, see page 33	Fixed wheels, complete	
5	2	Assy, see page 33	Brake wheels, complete	
6	1	Assy, see page 39	High shear and pump unit	
7	1	Assy, see page 35	Flush container, complete	1.4301
8	1	On request	Name plate	
10	1	Assy, see page 36	C-ball valve, complete	
11	<input type="checkbox"/>	1 9614232401	Frequency converter ROW	
	<input type="checkbox"/>	1 9614232402	Frequency converter CANADA/US	
12	1	On request	By-pass tube	1.4404
13	1	Assy, see page 37	Inlet tube, complete	
14	1	9611992672	Sight glass, complete	1.4404/EPDM
15	<input type="checkbox"/>	1 9612075325	Butterfly valve DIN inlet ROW	1.4404/EPDM
	<input type="checkbox"/>	1 9611904233	Butterfly valve Tri-Clamp inlet CANADA/US	1.4404/EPDM
16	4	On request	Screw and nut	A2
17*	1	9614295201*	100 l. funnel extension*	1.4301
18	2	9611900259	Seal	EPDM
19	1	On request	Blind cap (for CIP)	1.4301
20	1	9611900256	Seal	EPDM

*) Optional, not part of machine

Parts drawing, Powder Mixer complete, HPM-M15

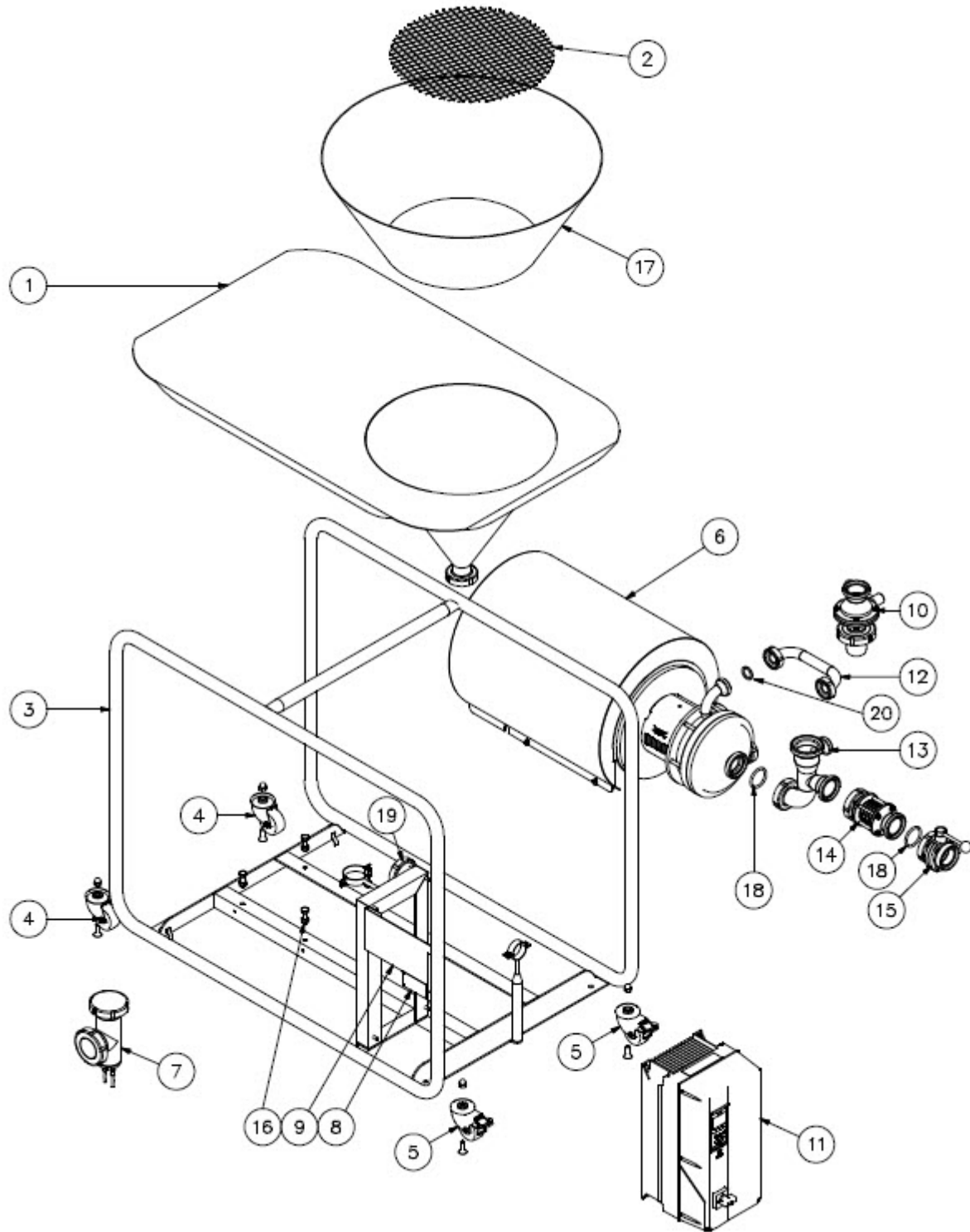

Parts list, Powder Mixer complete, HPM-S15

Pos.	Qty	Part number	Denomination	Material
1	1	Assy, see page 39	High shear and pump unit	
2	1	On request	By-pass tube	1.4404
3	1	9611900259	Seal	EPDM
4	1	Assy, see page 37	Inlet tube, complete	
5	1	On request	Blind cap (for CIP)	1.4301
6	1	On request	Funnel	1.4301
7	1	Assy, see page 35	Flush container, complete	1.4301
8	1	On request	Base frame, complete	1.4301
9	1	On request	Safety Mesh	1.4301
10	1	Assy, see page 36	C-ball valve, complete	
11	1	9611900256	Seal	EPDM
12*	1	9614295201*	100 l. funnel extension*	1.4301

Parts drawing, Powder Mixer complete, HPM-S15

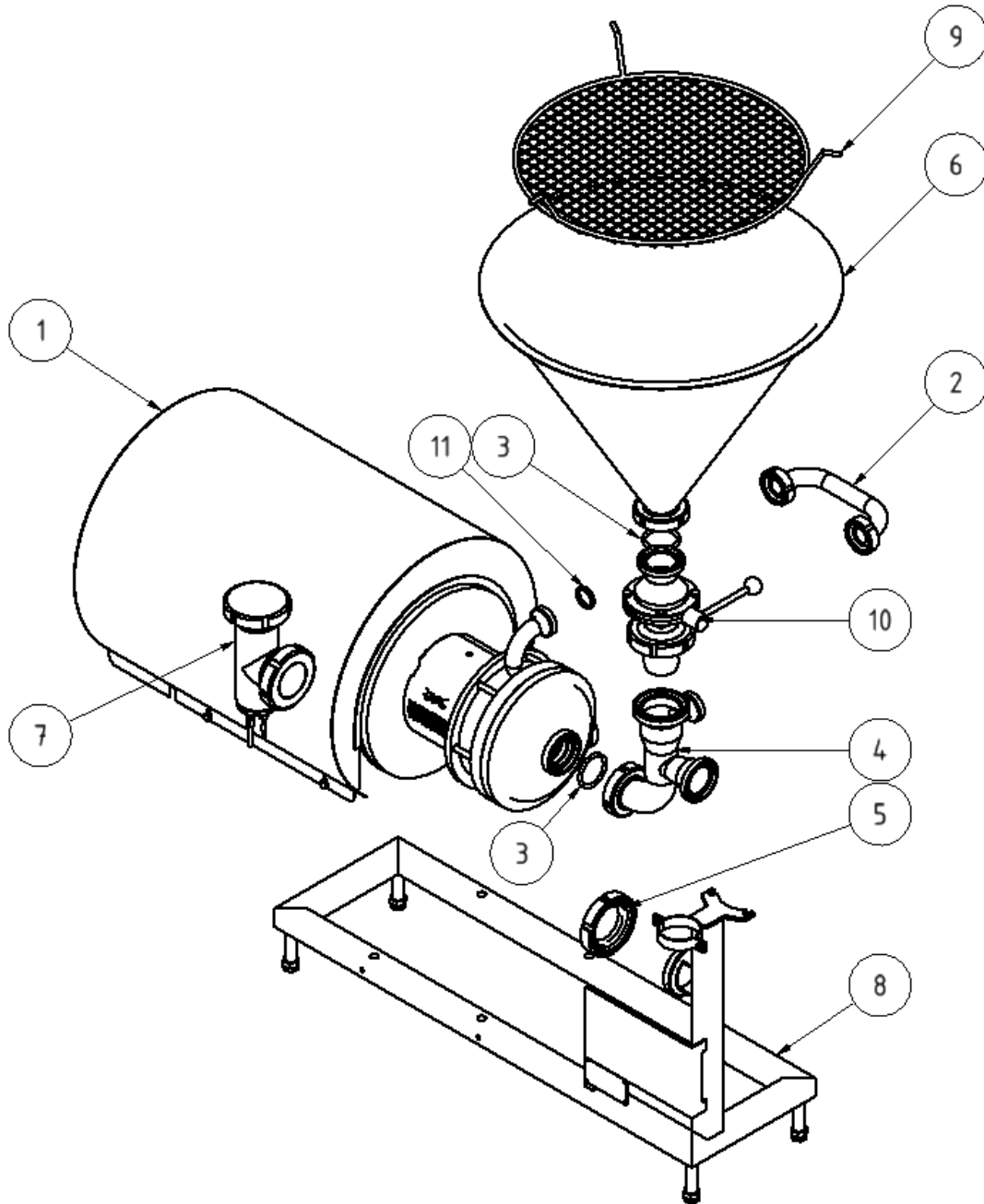

Parts list, Base frame, HPM-M15

Pos.	Qty	Part number	Denomination	Material
3.1	1	On request	Frame	1.4301
3.2	1	On request	Pipe clamp	1.4301
4.1	2	On request	Wheel	1.4301 / polyamide 6
4.2	2	On request	Screw	A2
4.3	2	On request	Nut	A2
5.1	2	On request	Wheel	1.4301
5.2	2	On request	Screw	A2
5.3	2	On request	Nut	A2
8	1	On request	Name plate	1.4301
16	4	On request	Screw and nut	A2

Parts drawing, Base frame, HPM-M15

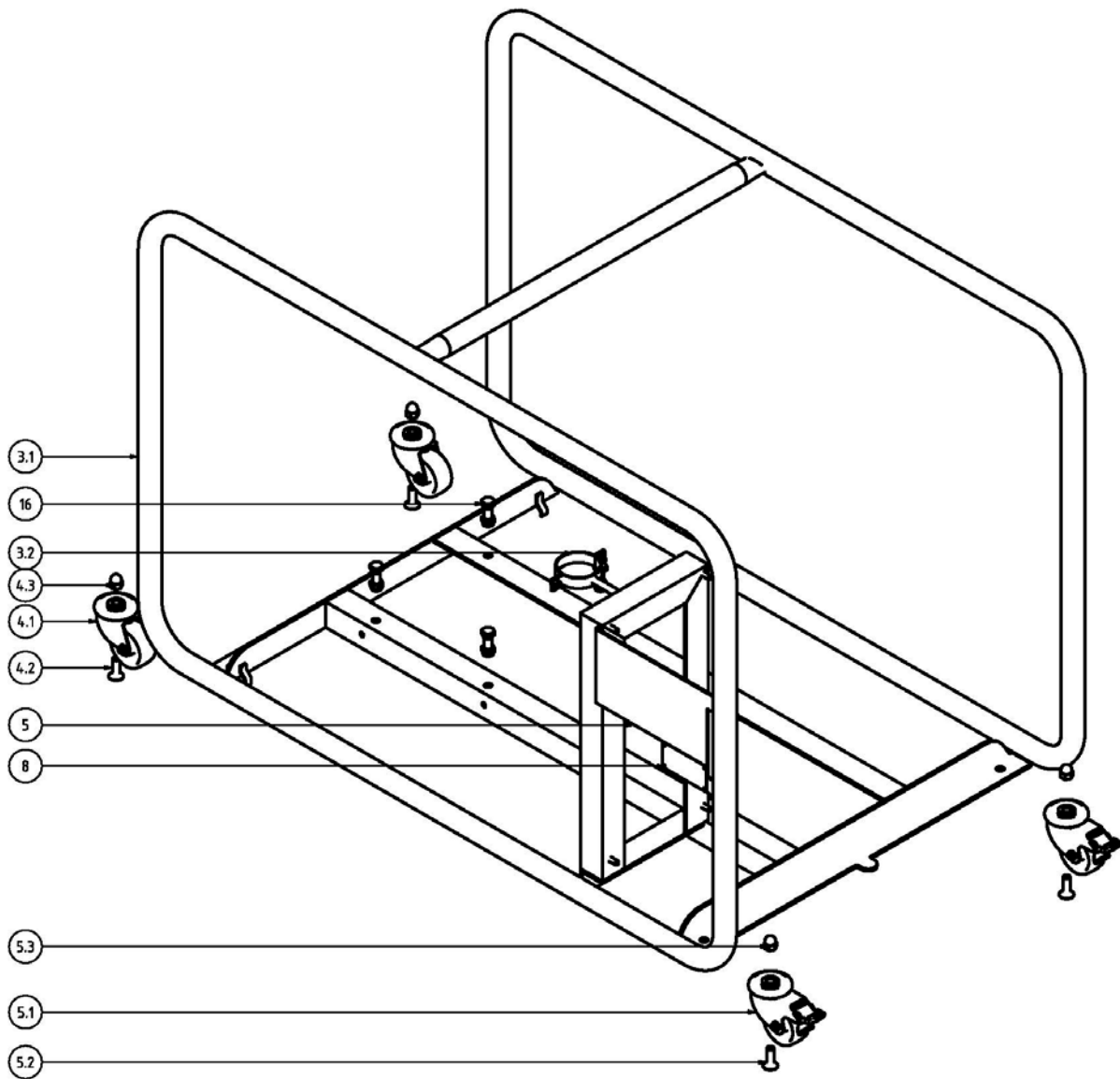

Parts list, Flush container, HPM-M15/HPM-S15

Pos.	Qty	Part number	Denomination	Material
7.1	1	On request	Nut, union	1.4301
7.2	1	On request	Sight glass	Borosilicate
7.3	1	On request	Seal	EPDM
7.4	2	On request	Tube connection	1.4404
7.5	1	On request	Flush container house	1.4301
7.6	1	On request	Seal	NBR
7.7	1	9611291481	Blind cap	1.4301
7.8	2	On request	Tube	PTFE

Parts drawing, Flush container, HPM-M15/HPM-S15

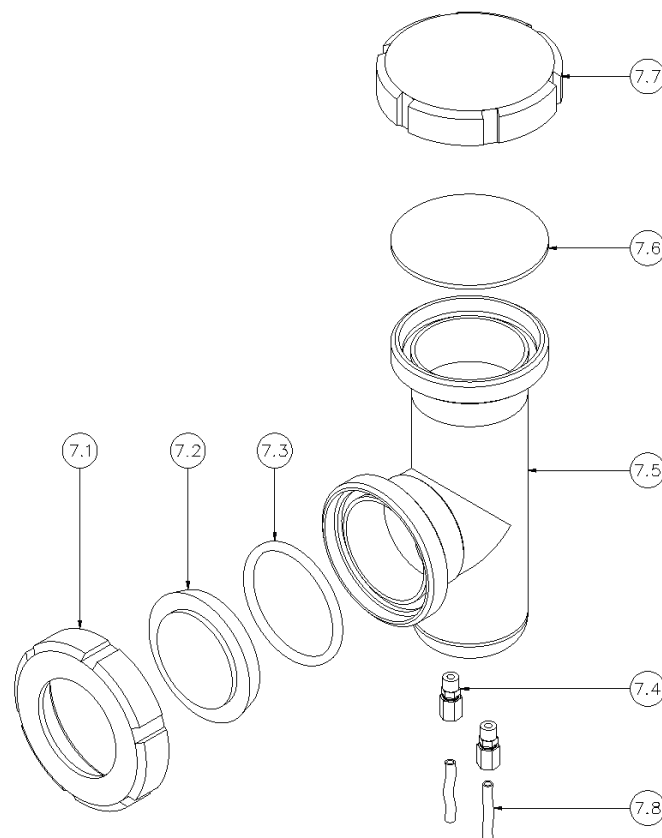

Parts list, C-ball valve, HPM-M15/HPM-S15

Pos.	Qty	Part number	Denomination	Material
10.1	1	9611900259	Seal	EPDM
10.2	1	On request	Handle	1.4301
10.3	1	On request	Ball valve threaded part	1.4404
10.4	1	On request	C-ball w. seal	1.4404/PTFE
10.5	1	On request	Ball valve cone part	1.4404
10.6	4	On request	Screw with nut	A2

Parts drawing, C-ball valve, HPM-M15/HPM-S15

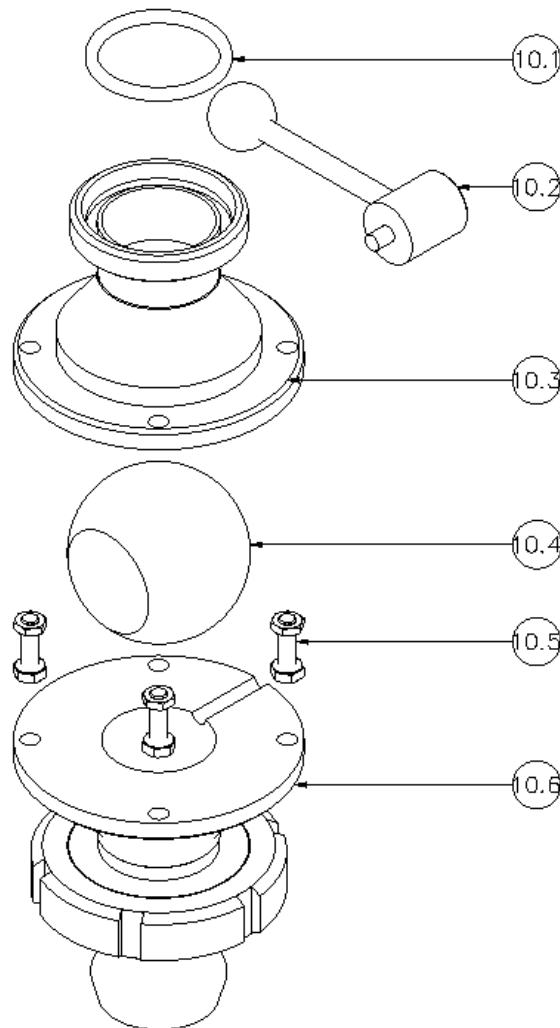

Parts list, Inlet tube, HPM-M15/HPM-S15

Pos.	Qty	Part number	Denomination	Material
13.1	1	9612906208	O-ring seal	EPDM
13.2	1	9611900256	Seal	EPDM
13.3	1	On request	Inlet tube	1.4404
13.4	1	9611900259	Seal	EPDM

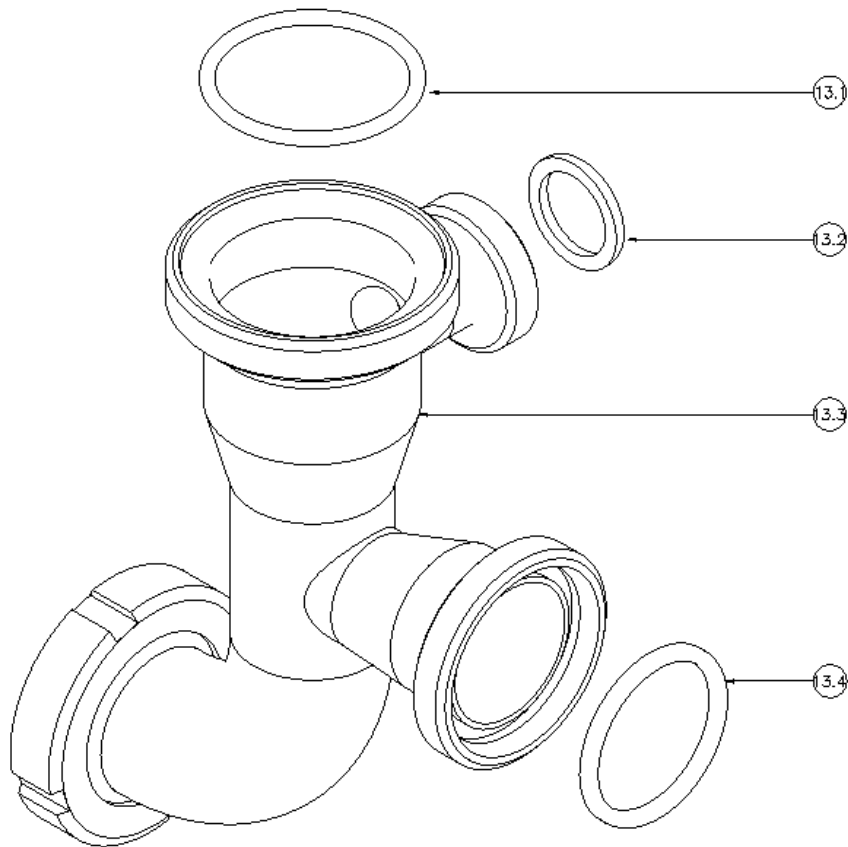
Parts drawing, Inlet tube

Parts list, Butterfly valve, HPM-M15

Pos.	Qty	Part number	Denomination	Material	
1	□	2	9612323901	Valve body half, welding	AISI 304L
	□	2	9612323902	Valve body half, welding	AISI 316L
1a	□	2	9612324601	Valve body half, male part	AISI 304L
	□	2	9612324602	Valve body half, male part	AISI 316L
2		1	9612073904	Disc	AISI 304
3		1	9611411890	Bush	
4		1	9611411890	Bush	
5		1	9612070301	Seal ring	EPDM
6		1	9611417350	Set screw, M8 + Nut M8	

Parts drawing, Butterfly valve, HPM-M15

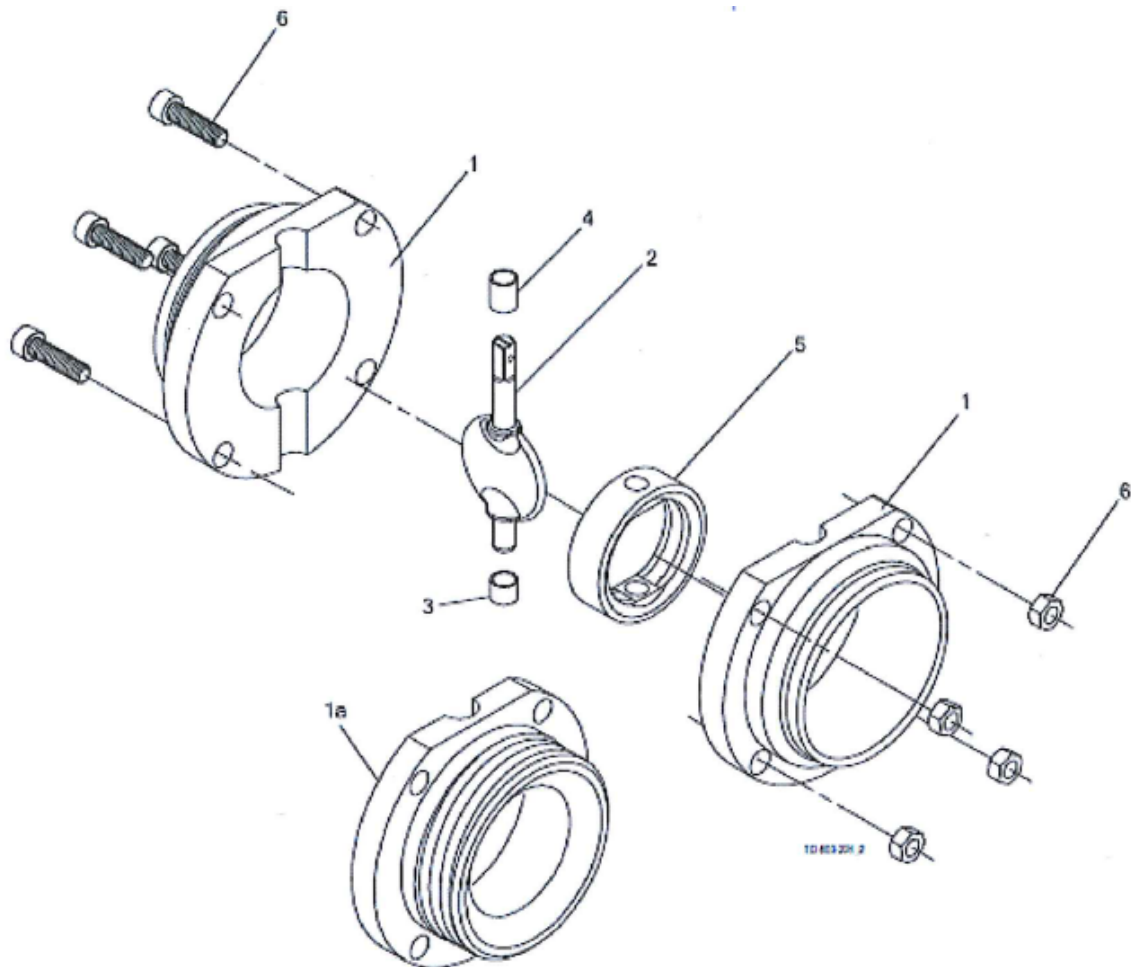

Parts list, High shear and pump unit, HPM-M15/HPM-S15

Pos.	Qty	Part number	Denomination	Material
42	1	On request	Pump house	1.4404
32	1	9611992744	O-ring	EPDM
45	1	On request	Extension ring	1.4404
46	1	On request	Rotor	1.4462
49	1	On request	Front plate / Stator	1.4462/1.4404

Please see parts list for LKH-112 in separate pump manual - the parts above are either additional, revised or replaced by components of the LKH-112 pump.

Parts drawing, High shear and pump unit, HPM-M15/HPM-S15

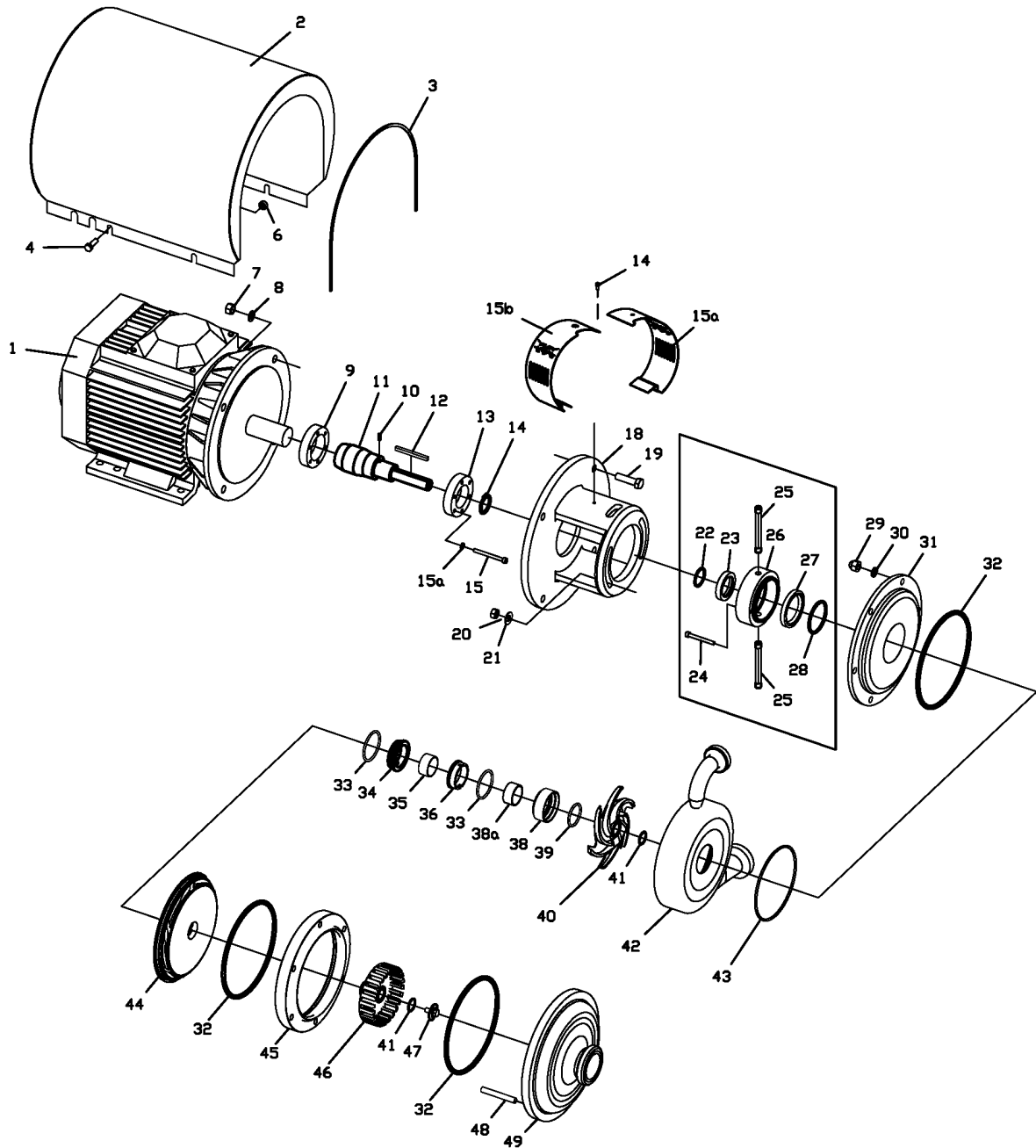

The drawing above is showing the ROW version - shroud pos. 2 is not included in the US/CANADA version since the motor is a Wash Down version

Additional documents

See Annex, Operating instructions for frequency converter and pump.

General Information

Service / Repair

The seals (both stationary and mechanical) are the same as on the standard LKH-112 pump - please see separate Spare Part documentation for LKH 112 pump where the seal material reference is SiC/SiC, EPDM.

Be aware that there is an extra O-ring seal (ref. pos. 32 in Parts Drawing, High shear and pump unit) compared to the standard LKH 112 unit.

All other seals - please find item numbers in the individual parts lists.

Warranty

The warranty conditions are subject to the legal warranty period of 12 months from the date of delivery. In case of improper use, modifications of or damages to the device, we do not accept warranty claims. Damaged devices will also not be accepted. Furthermore, defects due to normal wear are not subject to warranty services.

How to contact Alfa Laval

For further information please feel free to contact:

Alfa Laval Tank Equipment

Alfa Laval Kolding A/S

31, Albuen - DK 6000 Kolding - Denmark

Registration number: 30938011

Tel switchboard: +45 79 32 22 00 - Fax switchboard: +45 79 32 25 80

www.toftejorg.com , www.alfalaval.dk - info.dk@alfalaval.com

Contact details for all countries are continually updated on our websites.