



## **SSB Retractor Stroke 120 Media-to-Spring**

Models: TE75P031, TE75P031-04, TE75P051 & TE75P051-04

- Covering**
- **Standard Machines**
  - **Machines delivered with ATEX Certification in accordance with Directive 94/9/EC**



**IM-TE91A903-EN1**

ESE02198

Date of issue: January 19, 2012  
First published: January 19, 2012



# Contents

|   |    |
|---|----|
| Contents .....  | 1  |
| Introduction .....  | 3  |
| Intended Use .....  | 4  |
| Patents and trademarks .....  | 4  |
| ATEX Marking .....  | 5  |
| Design Overview .....   | 5  |
| Applications .....  | 6  |
| Options .....   | 6  |
| SSB Retractor Unit in extended position .....   | 7  |
| Accessories .....   | 8  |
| Technical Data.....   | 9  |
| Materials .....   | 9  |
| Connections.....  | 9  |
| Available add-ons (documentation).....  | 10 |
| Flow Rate Data.....   | 11 |
| Installation dimensions and connections.....  | 12 |
| Dimensions .....  | 12 |
| Installation .....  | 14 |
| General Safety and Installation Instructions.....   | 15 |
| Special Conditions for Safe Use in accordance with the ATEX Certification, Directive 94/9/EC..... | 16 |
| Warnings .....  | 20 |
| Fluid connections.....  | 20 |
| Important recommendation for installation .....   | 20 |
| Service and Repair of ATEX Approved Machines .....  | 21 |
| Recommended Service Intervals .....   | 21 |
| Component parts .....   | 22 |
| List of parts .....   | 22 |
| Parts drawing.....  | 23 |
| Maintenance .....   | 24 |
| Dismantling the Unit for Inspection .....   | 24 |
| Re-Build & fitment of New Service Repair Kit .....  | 32 |
| Standard Service Kits .....   | 40 |
| How to order Spare Parts and Claim Procedure.....   | 41 |
| How to contact Alfa Laval Tank Equipment A/S.....   | 41 |
| EC Declaration of Conformity.....   | 42 |
| ATEX-Special Conditions for safe use .....  | 44 |



## Introduction

The SSB Retractor is a cleaning media operated targeted spray ball which has been designed to achieve fast effective cleaning of all equipment used in the production process, including Ductwork, Vent Lines, Cyclones and many other applications where access is impossible

This manual has been prepared as a guide for the persons who will be operating and maintaining your tank cleaning machine. The key to long life for your tank cleaning machine will always be a system of carefully planned maintenance; you will appreciate that a tank cleaning machine which has a rough and dirty job to do will need more frequent attention than one working in ideal conditions.

It is in your own interest to get the best and most economical performance from your tank cleaning machine. Neglect of maintenance means poor performance, unscheduled stoppages, shorter life and expense. Good maintenance means good performance; no unscheduled stoppages and better total economy.

You will find the information contained in this manual simple to follow, but should you require further assistance, our Customer Service Department and world-wide net of Distributors will be pleased to help you. Please quote the type and serial number with all your enquiries; this will help us to help you.

The type and serial number are placed on the side of the body of the tank cleaning machine.

**Note:** The illustrations and specifications contained in this manual were effective at the date of printing. However, as continuous improvements are our policy, we reserve the right to alter or modify any unit specification on any product without prior notice or any obligation.

© 2012 Alfa Laval Corporate AB

*This document and its contents is owned by Alfa Laval Corporate AB and protected by laws governing intellectual property and thereto related rights. It is the responsibility of the user of this document to comply with all applicable intellectual property laws. Without limiting any rights related to this document, no part of this document may be copied, reproduced or transmitted in any form or by any means (electronic, mechanical, photocopying, recording, or otherwise), or for any purpose, without the expressed permission of Alfa Laval Corporate AB. Alfa Laval Corporate AB will enforce its rights related to this document to the fullest extent of the law, including the seeking of criminal prosecution.*

## Intended Use

It is to be verified by the end-user:

- that the tank cleaning machine is in conformity with respect to tank, vessel, container or duct size in which it will be used.
- that the construction materials (both metallic and non-metallic) are compatibility with product, flushing media, cleaning media, temperatures and pressure under the intended use.

## Patents and trademarks



This Instruction Manual is published by Alfa Laval Tank Equipment A/S without any warranty. Improvements and changes to this Instruction Manual may at any time be made by Alfa Laval Tank Equipment A/S without prior notice. Such changes will, however, be incorporated in new editions of this Instruction Manual.

© Alfa Laval Tank Equipment A/S, 2012. All rights reserved.

The Alfa Laval logotype is a trademark or a registered trademark of Alfa Laval Corporate AB. "Toftejorg" is a trademark or registered trademark of Alfa Laval Tank Equipment A/S. Other products or company names mentioned herein may be the trademarks of their respective owners. Any rights not expressly granted herein are reserved

## If ordered with ATEX certificate: ATEX Marking

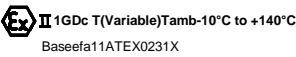
The SSB Retractor - Mini Retract-A-Ball is certified as category I components. The certification is carried out by the notified body Baseefa, who has issued the certificate Baseefa 11ATEX0231X. The marking on the ATEX certified SSB Retractor - Mini Retract-A-Ball is as follows:

|   |   |   |
|---|---|---|
| <br>Alfa Laval Tank Equipment A/S<br>Baldershoej 19, Ishoej-DK | Type: SSB Retractor 120/M/S Duct EPDM<br>Art Nr: TE75P051<br>s/n: SSB-R-XXXX-XX-XX<br>Tag No: XXXXX | Sequential number<br>Month<br>Year  |
|    | Temp: 140 deg C Max.<br>Media Pressure: 4 Bar Max.  |  |

### Note:

TE75P031-04 and TE75P051-04

These machines are approved for 180°C max: Tamb -10°C to +180°C.

Changes to the machine are not allowed without approval by the person responsible for the ATEX certification at Alfa Laval Tank Equipment A/S. If changes are made – or spare parts other than Alfa Laval original spare parts are used - the EC Type Examination certification (the ATEX Directive) is no longer valid.

### Important ATEX information:



Also see page 20 regarding special conditions for repair of ATEX certified machines.

## Design Overview

The unit has been designed to extend the sprayball into the duct or vessel when the CIP cleaning media is applied. After the CIP cycle & the cleaning media pressure is removed the sprayball will be pulled back into the Home Chamber by the internal spring. Once the Sprayball is in the closed position the sprayball cap will seal with the Home Chamber to ensure the sprayball is isolated from the duct or vessel.

## Applications

The SSB Retractor can be used to clean from simple tanks and ductwork, to complex process applications with agitators where it is not possible to use fixed spray balls. Applications such as Storage Tanks, Reactors, Mixers and Spray Dryers including Ductwork and Vent Lines can all be cleaned by use of one or multiple SSB Retractor units.

**ATEX  
Warning:**



The speed at which the Sprayball is deployed (extended to the open position) must not exceed 0.5m/s. Ensure that the cleaning media pressure does not exceed to 4 bar max.

## Options

The units are available in a range of operating strokes. As standard there are two sizes of SSB Retractor—60mm and 120mm. However, both units can be adjusted during manufacture by increments of 10mm. This allows the units to be fine tuned to accurately position the spray ball optimising the effectiveness.

As standard the units are available with all machined components in 316L Stainless Steel and standard seals in EPDM and Carbon filled PTFE. However, the units are available with wetted components in Hastelloy C22 and seals manufactured from Perfluorolastomer should the environment require.

The spray balls are offered with standard spray patterns or can be target drilled to direct cleaning to certain features such as access covers etc.



# SSB Retractor Unit in extended position



Figure 1 SSB, extended position

## Accessories

The unit can be supplied with proximity sensors to indicate that the unit is either fully open, fully closed, or both. If this option is required, a sensor part number: TE75P507 will be required for each position.

If the SSB Retractor is being ordered with ATEX Certification it is important to note that if a sensor is fitted the ATEX Category & Zone in which the SSB Retractor can be used will be effected.

The SSB Retractor is ATEX Category 1 but if sensors are fitted the unit will assume the lower ATEX rating of the Proximity Sensor.

If sensors are required for an ATEX environment please consult Alfa Laval.

**ATEX  
Warning:**



It is important to note that the SSB Retractor is ATEX Category 1 for installations in zone 0/20.

However, if Proximity sensors are fitted the overall ATEX rating of the SSB Retractor will assume the lower ATEX rating of the proximity sensor.

## Technical Data

|                    |          |             |
|--------------------|----------|-------------|
| Model /Article No. | TE75P031 | TE75P031-04 |
|                    | TE75P051 | TE75P051-04 |

|                           |  |  |
|---------------------------|--|--|
| Weight of Unit            | : 3.6kg  | 3.6kg  |
| Cleaning Fluid Pressure   | : 2 - 4 bar (29 - 58 psi)  | 2 - 4 bar (29 - 58 psi)  |
| Flow Rate Approx.         | : 2.8m <sup>3</sup> / hr at 3 bar                                  | 2.8m <sup>3</sup> / hr at 3 bar                                  |
| Max. Cleaning Fluid temp. | : 95° C (203 deg F)  | 95° C (203 deg F)  |
| Max. Process temp.        | : 140° C (284 deg F)   | 180° C (356 deg F)   |
| Ambient temp.             | : -10° C to +140° C<br>(95° C – 140° C - when <b>not</b> operated) | -10° C to +180° C<br>(95° C – 180° C - when <b>not</b> operated) |

## Materials

|            |                            |  |
|------------|----------------------------|--|
| Components | : Stainless Steel 316L     | Stainless Steel 316L                               |
| Spring     | : Stainless Steel 301S81   | Stainless Steel 301S81                             |
| Seals      | : EPDM, Carbon Filled PTFE | Isolast-(Perfluorolastomer),<br>Carbon Filled PTFE |
| Gaskets    | : PTFE                     | PTFE   |

## Connections

|                           |   |
|---------------------------|---|
| Cleaning Media Connection | : 1" ISO Flange                         |
| Vessel Mounting           | : 2" ISO Flange                         |
| Body Tube Joints          | : Flanged/Clamped to DIN 40 (DIN 32676) |

## Technical Data (continued)

### Available add-ons (documentation)

|             |                         |
|-------------|-------------------------|
| TE75P0X1-70 | EPDM + ATEX             |
| TE75P0X1-80 | EPDM + ATEX + 3.1 cert. |
| TE75P0X1-90 | EPDM + 3.1 cert.        |
| TE75P0X1-74 | FFKM + ATEX             |
| TE75P0X1-84 | FFKM + ATEX + 3.1 cert. |
| TE75P0X1-94 | FFKM + 3.1 cert.        |

### Explanation to Add-ons:

#### **ATEX** includes:

ATEX approved machine for use in explosive atmospheres. Category 1 for installation in zone 0/20 in accordance to Directive 94/9/EC. Ex II 1GD c T(Variable) Tamb -10°C to +140°C or Ex II 1GD c T(Variable) Tamb -10°C to +180°C.

# Flow Rate Data

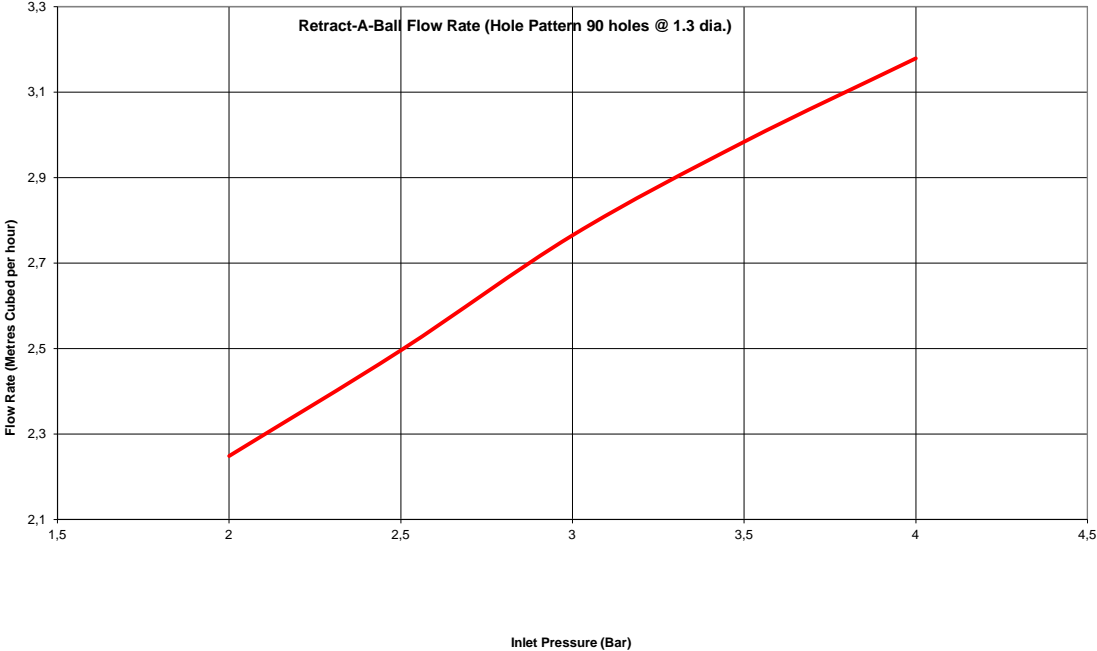

The above Flow Chart shows the typical flow rate through the SSB Retractor fitted with a standard spray ball with 90 holes at 1.3mm dia.

Flow Rates can be changed by different drilling patterns if required.

## Installation dimensions and connections

### Dimensions

Figure 2 Dimensions

## Installation dimensions and connections

### NOTES:

- |                       |   |
|-----------------------|---|
| 1. MATERIALS:         | MACHINED COMPONENTS: STAINLESS STEEL - GRADE 316L                         |
| 2. SEALS:             | MACHINED CARBON FILLED PTFE, EPDM or ISOLAST O-RINGS                      |
| 3. SPRING:            | STAINLESS STEEL - GRADE 301S81<br>(NON-WETTED)                            |
| 4. BODY JOINTS:       | DIN 40 FLANGES.<br>DESIGNED IN ACCORDANCE WITH DIN 32676. (SAFETY CLAMPS) |
| 5. PRESSURES:         | CLEANING LIQUID: 2-4 bar (29-58 psi)                                      |
| 6. TEMPERATURES:      | CLEANING LIQUID: 95°C (203°F) MAX PROCESS: 140°C (284°F)                  |
| 7. LIQUID CONNECTION: | 1" ISO FLANGE   |
| 8. BODY MOUNTING:     | 2" ISO FLANGE   |

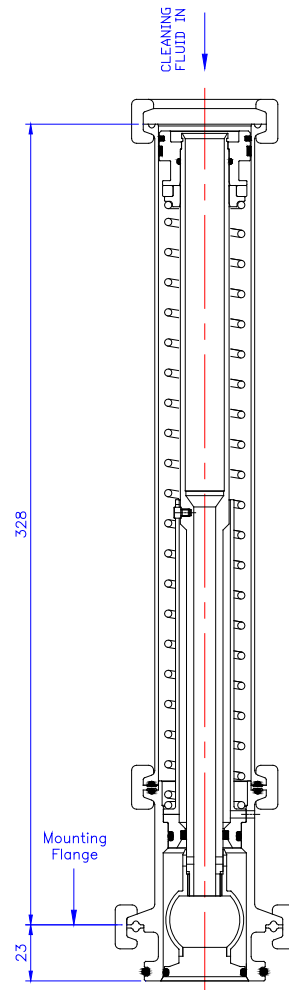

Figure 3 Connections

# Installation

The SSB Retractor is mounted to a 2" ISO Ferrule using the 2" ISO gasket and clamp supplied. The unit must be mounted so that it is a minimum for 5° above horizontal. This is important to allow the Home Chamber to drain when cleaning has finished. See Figure 4.

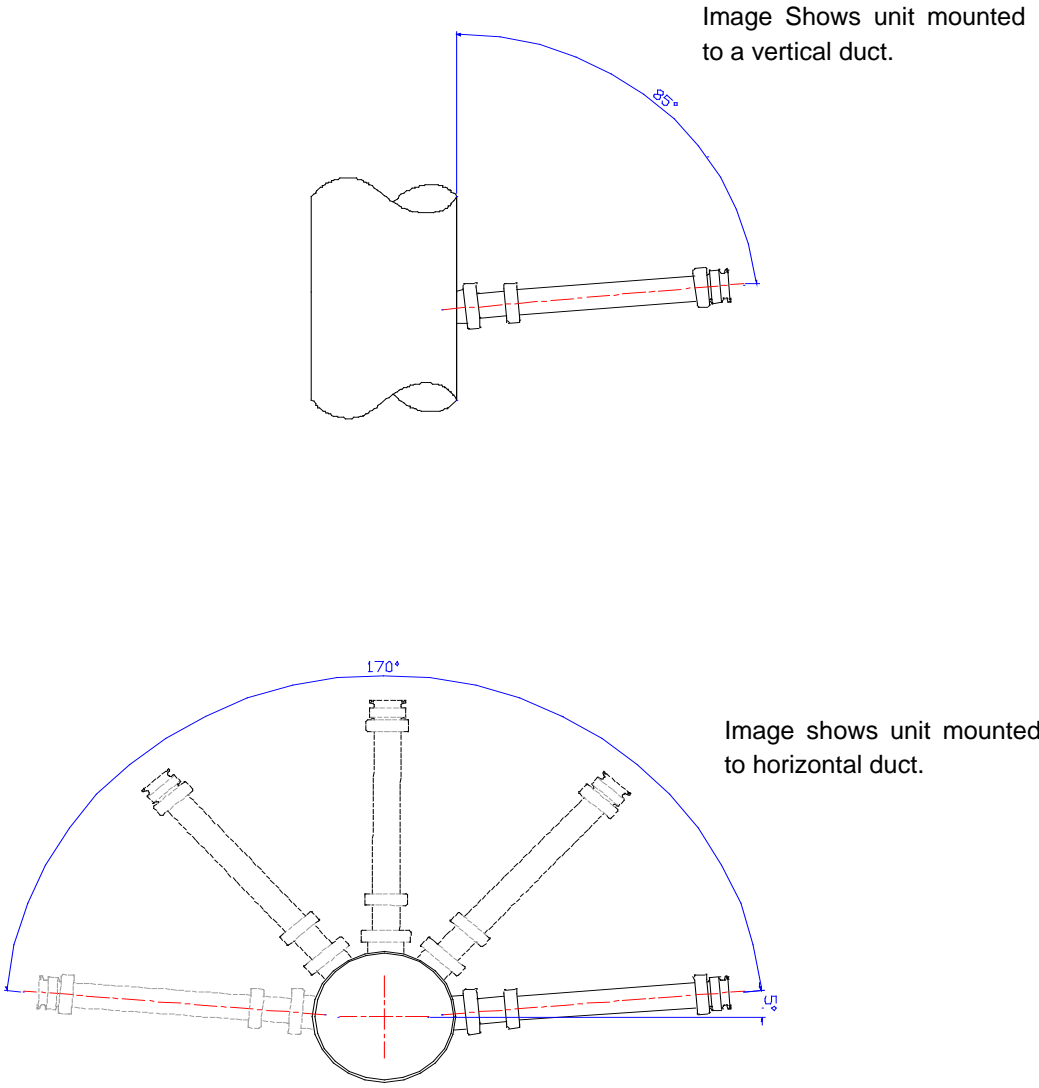

Figure 4 Installation



## Installation (continued)

### General Safety and Installation Instructions

**Note:** The machine shall be installed in accordance with national regulations for safety and other relevant regulations and standards.

Precautions shall be made to prevent starting of the cleaning operation, while personnel are inside the tank or otherwise can be hit by jets from the nozzles.

In EU-countries the complete system must fulfil the EU-Machine Directive and depending of application, the EU-Pressure Equipment Directive, the EU-ATEX Directive and other relevant Directives and shall be CE-marked before it is set into operation.

**Warning:**



If the machine is used in potential explosive atmospheres, tapes or joint sealing compounds which are electrical insulators must not be used on threads or joints, unless an electrical connection is otherwise established to ensure an effective earthing. In addition, connecting pipe work, must be electrically conductive and earthed to the tank structure. The resistance between the nozzles and the tank structure should not exceed 20,000 Ohm. This is essential to avoid the build-up of static electricity on the machine.

For further information see DS/CLC/TR 50404:2003 Safety of Machinery, guidance and recommendations for the avoidance of hazards due to static electricity.

Electrical equipment such as magnetic valves and electric actuators must not be installed in Ex-zones without type approval and marking, corresponding to the EX-class in question.

## Installation (continued)

### Special Conditions for Safe Use in accordance with the ATEX Certification, Directive 94/9/EC

**ATEX Warning:** The unit shall be connected to a fully earthed pipeline/duct or tank/vessel.



**ATEX Warning:** The pipeline/duct shall not exceed a diameter of 3m, and the tank/vessel shall not exceed 100m<sup>3</sup>.



**ATEX Warning:** The air operated units shall only be operated with inert gas or clean air.



**ATEX Warning:** The unit shall only be purged with inert gas or clean air



**In addition to the above mentioned precautions relating to the ATEX guidelines Directive 94/9/EC of March 23 1994, the Safety Precautions on page 14 must be observed.**

## Installation (continued)

### Special Conditions for Safe Use in accordance with the ATEX Certification, Directive 94/9/EC - Continued.

**ATEX Warning:** Do not allow the unit to be operated when process media is in the pipeline or tank.



**ATEX Warning:** Do not allow the air pressure to exceed 5.5 bar. (Air operated units only)



**ATEX Warning:** Do not allow the cleaning media to exceed 4 bar.



**ATEX Warning:** When an external sensor is fitted to indicate the open or closed position it shall be suitable for the zone in use.





**In addition to the above mentioned precautions relating to the ATEX guidelines Directive 94/9/EC of March 23 1994, the Safety Precautions on page 14 must be observed.**

## Installation (continued)

### Special Conditions for Safe Use in accordance with the ATEX Certification, Directive 94/9/EC –(continued)

#### Temperature

|   |   |
|---|---|
| <b>ATEX Warning:</b><br> | <u>Atmosphere/surface temperature:</u><br>In potentially explosive atmospheres, the temperature must not exceed the maximum surface temperature according to the temperature class for the combustible gas or liquid. |
|---|---|

|   |  |
|---|--|
| <b>ATEX Warning:</b><br> | <u>Steam cleaning:</u><br>Tanks with capacities greater than 100 m <sup>3</sup> that could contain a flammable atmosphere should not be steam cleaned, as steam issuing from a nozzle could contain charged droplets.<br><br>Tanks smaller than this may be steam cleaned providing that: the steam nozzles and other metal parts of the system are reliably earthed and grounded to the tank structure. |
|---|--|

#### Pressure

Avoid hydraulic shocks. Increase pressure gradually. Do not exceed 4 bar inlet pressure. Recommended inlet pressure: 2-4 bar. High pressure in combination with high flow rate will increase consumption of wear parts. High pressure will also reduce the cleaning effect.

|   |  |
|---|--|
| <b>ATEX Warning:</b><br> | <u>Steam cleaning pressure:</u><br>If steam cleaning is done through the machine, the steam pressure must not cause the machine to rotate. |
|---|--|

|   |  |
|---|--|
| <b>ATEX Warning:</b><br> | <u>Draining:</u><br>If the machine is drained using compressed air, then the compressed air pressure must not cause the machine to rotate. |
|---|--|

## Installation (continued)

### Orientation

As the Spray Ball on the SSB Retractor is often targeted it is important that the unit is installed in the correct orientation. The Spray balls are keyed to the Home Chamber. The Home Chamber has a roll pin fitted through its side. See Figure 5

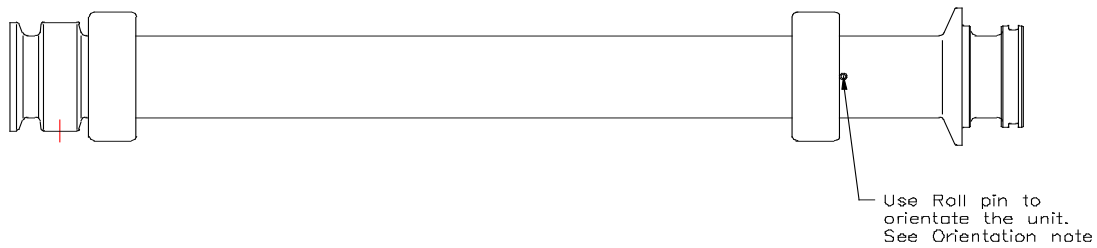

Figure 5 Installation orientation

Once the unit is mounted into the 2" ISO mounting ferrule it should be rotated so that the roll pin points parallel to the duct work to which it is mounted, before the mounting clamp is tightened. This will ensure the correct orientation for the Spray Ball.

In some instances the units may be specially drilled to target certain features or may not be mounted into ductwork. In these instances, the roll pin should again be used to orientate the unit but there will be an instruction enclosed with the unit to advise the direction the pin should point.

It is recommended that a filter with 0.5mm holes is fitted to the supply line.

Before connecting the Cleaning Media Pipe work to the unit it is recommended that the supply lines and valves should be flushed in order to remove any foreign particles.

## Installation (continued)

### Cleaning Media

The media must be compatible with Stainless Steel 316L, EPDM or ISOLAST and carbon filled PTFE. Normal detergents, moderate solutions of acids and alkaline are acceptable.

### After Use Cleaning

After use the units should always be flushed with fresh water. Cleaning media should never be allowed to dry inside the unit due to possible 'salting out' or scaling of the cleaning media.

## Warnings

**Warning:** The unit is operated by Cleaning Media. It is important that the Cleaning Media pressure is released and isolated before any work is carried out on the unit.



The clamps used on the body of the unit are safety clamps and **cannot** come away from the unit if the clamping nut is accidentally slackened, however great care must be taken.

### Fluid connections

The unit is supplied with cleaning media (fluid) at pressure. Ensure that the supply is isolated before work starts on the unit.

### Important recommendation for installation

It is recommended that the media connection to the SSB Retractor is always by means of a flexible, not fixed, coupling/pipe work. This is important to ensure that there is no undue force applied to the unit which can cause internal misalignment and therefore damage.

## Service and Repair of ATEX Approved Machines

In order to ensure compliance with the ATEX regulations for service and repair in accordance with EN 60079-19, all service and repair of ATEX approved machines should be performed by Alfa Laval Tank Equipment A/S, Ishoej, Denmark.

**Warning:** ATEX requirements regarding repair of ATEX approved machines according to EN 60079-19.



A tag with the following labelling information must be attached to the machine:

- Repair symbol 
- Alfa Laval logo and address
- Repair number
- Date of repair
- Machine serial number

The tag must be laminated and attached to the machine using a cable tie.

If a customer wishes to carry out service or repair himself, it is the responsibility of the repair shop to ensure that the ATEX requirements are met in any way possible. After performing service or repair, the repair shop thus carries the full responsibility for the ATEX approval of the machine.

## Recommended Service Intervals

Inspection every 500 working hours. After 2000 working hours: inspection every 200 hours.

An Inspection consists of: SEE PAGE 23.

## Component parts

### List of parts

| Model No. | TE75P031 | TE75P031-04 | TE75P051 | TE75P051-04 |                               |     |            |
|-----------|----------|-------------|----------|-------------|-------------------------------|-----|------------|
| Pos.no.   | Ref. No. | Ref. No.    | Ref. No. | Ref. No.    | Description                   | QTY | Remarks    |
| 1         | TE75P526 | TE75P526    | TE75P526 | TE75P526    | Body Tube                     | 1   | Spare Part |
| 2         | TE75P569 | TE75P569    | TE75P569 | TE75P569    | Sleeve                        | 1   | Spare Part |
| 3         | TE75P570 | TE75P570    | TE75P570 | TE75P570    | Spray Stem                    | 1   | Spare Part |
| 4         | TE75P592 | TE75P592    | TE75P562 | TE75P562    | Spray ball assembly (drilled) | 1   | Spare Part |
| 5         | TE75P563 | TE75P563    | TE75P563 | TE75P563    | Housing 2" ISO                | 1   | Spare Part |
| 6         | TE75P544 | TE75P544    | TE75P544 | TE75P544    | Piston                        | 1   | Spare Part |
| 7         | TE75P545 | TE75P545    | TE75P545 | TE75P545    | Piston Spacer                 | 1   | Spare Part |
| 8         | TE75P572 | TE75P572    | TE75P572 | TE75P572    | Spring                        | 1   | Spare Part |
| 9         |          |             | TE75P502 | TE75P502    | Orientation Screw             | 1   | Spare Part |
| 10        | TE75P551 | TE75P551    | TE75P551 | TE75P551    | External Circlip              | 1   | Spare Part |
| 11        | TE75P552 | TE75P552    | TE75P552 | TE75P552    | Spring Pin                    | 1   | Spare Part |
| 12        | TE75P504 | TE75P504    | TE75P504 | TE75P504    | Magnet                        | 1   | Spare Part |
| 13        | TE75P505 | TE75P505    | TE75P505 | TE75P505    | Mounting Clamp 2" ISO         | 1   | Spare Part |
| 14        | TE75P506 | TE75P506    | TE75P506 | TE75P506    | Body Clamp DIN 40             | 1   | Spare Part |
| 15        |          |             |          |             |                               |     |            |
| 16        |          |             |          |             |                               |     |            |
| 17        | TE75P538 | TE75P508    | TE75P538 | TE75P508    | Home Chamber/Spigot Seal      | 1   | Wear Part  |
| 18        | TE75P539 | TE75P509    | TE75P539 | TE75P509    | Home Chamber/Stem Seal        | 1   | Wear Part  |
| 19        | TE75P550 | TE75P550    | TE75P550 | TE75P550    | Gasket-Home Chamber           | 1   | Spare Part |
| 20        | TE75P573 | TE75P573    | TE75P573 | TE75P573    | Solid Gasket Spacer Ring      | 1   | Spare Part |
| 21        | TE75P543 | TE75P543    | TE75P543 | TE75P543    | Stem Product Seal             | 1   | Wear Part  |
| 22        | TE75P540 | TE75P574    | TE75P540 | TE75P574    | Home Chamber/Sleeve Seal      | 1   | Wear Part  |
| 23        | TE75P541 | TE75P575    | TE75P541 | TE75P575    | Piston/Stem Seal              | 1   | Wear Part  |
| 24        | TE75P514 | TE75P514    | TE75P514 | TE75P514    | Piston Slide Ring             | 1   | Wear Part  |
| 25        | TE75P586 | TE75P586    | TE75P586 | TE75P586    | Piston Seal                   | 1   | Wear Part  |
| 26        | TE75P516 | TE75P546    | TE75P516 | TE75P546    | Energising O-Ring             | 1   | Wear Part  |
| 27        | TE75P511 | TE75P511    | TE75P511 | TE75P511    | O-Ring                        | 2   | Wear Part  |
| 28        | TE75P555 | TE75P555    | TE75P555 | TE75P555    | Ball Securing Pin             | 1   | Spare Part |



**Component parts (continued)**

**Parts drawing**

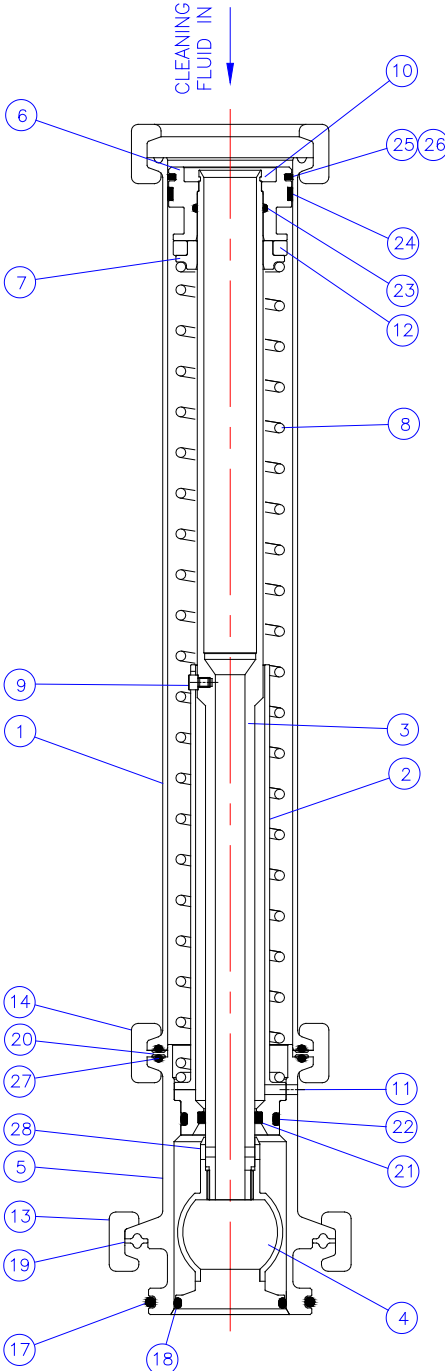

Figure 6 Component Parts

## Maintenance

The units are designed to be self cleaning and should require very little or no maintenance between service intervals.

Performance will be effected by contamination from debris or particles where the CIP system is inadequately filtered or swarf in the system after installation.

Deterioration of the seals will also affect the unit's performance.

It is for this reason that it is recommended that the units are inspected every 500 working hours. After 2000 working hours inspect every 200 working hours.

A spares seal kit is available and does require simple tooling to fit the seals. The part No. for the seal kit is listed in the Spare Parts section of this Manual on page 39.

## Dismantling the Unit for Inspection

1. Always release the CIP media connection to the unit.
2. Remove the unit from its mounting so that the work can be carried out in the workshop. To remove the unit release the 2" ISO clamp which retains it to the 2" ISO mounting ferrule (it is the largest clamp on the unit). Carefully draw the unit from the ferrule ensuring that you retain the white PTFE gasket between the mounting ferrule and the head of the unit.
3. Slacken and remove the DIN 40 clamp which secures the main body tube to the Home Chamber. Carefully withdraw the Body Tube. See Figure 6 below.

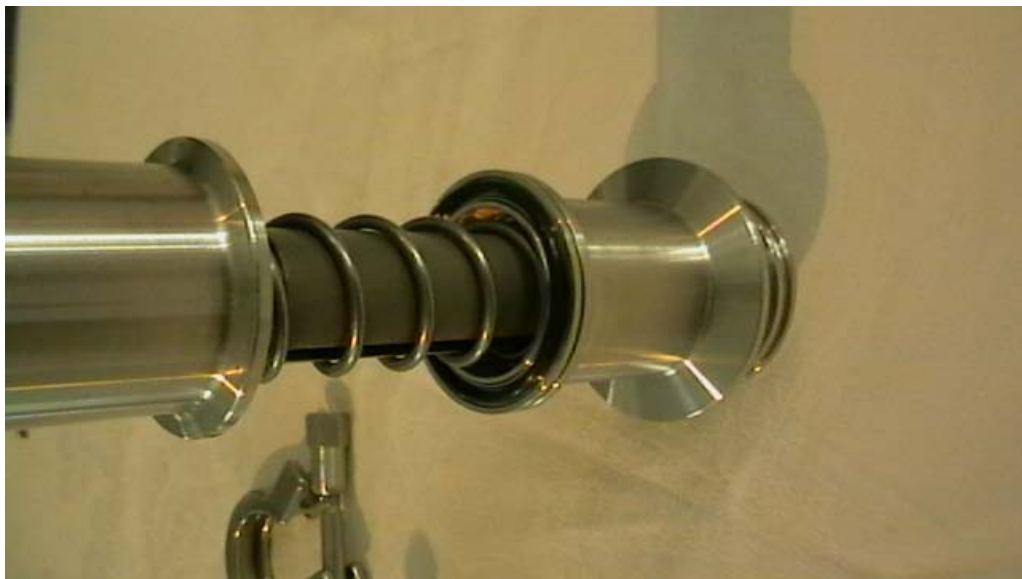

Figure 6 Dismantling

## Maintenance (continued)

4. There is a Solid Gasket Spacer Ring & two O-rings between the Home Chamber & the Body Tube.

The Solid Gasket Spacer Ring (TE75P573) should be retained for re-assembly but the two O-rings (TE75P511) should be replaced. See Figure 8 below.



Figure 7

5. Once the Body Tube is removed the Piston Slide ring will fall away from the Piston. This is normal. See Figure



Figure 9

## Maintenance (continued)

- CAUTION:** To remove the Piston the Circlip inside the recess of the Piston has to be removed. The Spring is under compression at this stage so the Piston must be held downwards as the Circlip is removed to avoid the Piston being ejected by the spring. See Figure . When rebuilding the Unit a new Circlip must be used.



Figure 10

- The remaining seal visible on the Piston in Figure 1 is the Main Air Seal. This seal is a PTFE ring with an O-Ring underneath to energise the seal.



Figure 11

## Maintenance (continued)

8. Look inside the piston, there is an O-Ring which seals the piston to the spray stem. This seal should be carefully removed using a small sharp pointer pressed into the O-Ring. The O-Ring must be discarded. See Figure 12



Figure 12

9. Remove the spring from the remaining body of the SSB Retractor.

## Maintenance (continued)

10. Remove the Orientation Screw (if fitted) from the Spray Stem as shown in Figure 3 using a 2.5mm Allen key. Retain the screw as it will be required in the re-build.

The Orientation Screw is fitted to ensure the orientation of the spray pattern. If the unit is fitted with a general coverage spray pattern the Orientation Screw may not be fitted.

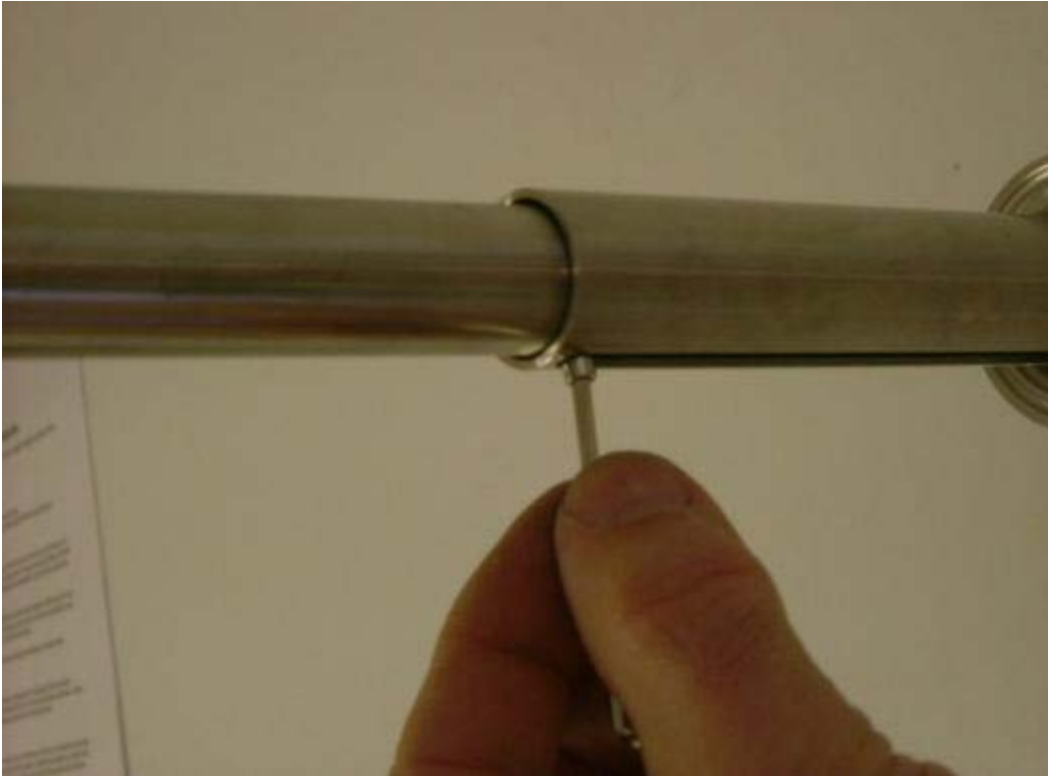

Figure 13

## Maintenance (continued)

11. Once the orientation screw is removed, push the spray stem forward to reveal the spray ball. The Sprayball is retained by a 2mm diameter pin which passes through the neck. Straighten the end of the pin with a pair of pliers. See Figure 14.



Figure 14

12. Once the Pin is removed the Sprayball can be unscrewed (anti clockwise) & removed. The Securing Pin must be discarded. See Figure 15



Figure 15

## Maintenance (continued)

13. The spray stem can now be drawn out of the main housing. See Figure 16.



Figure 16

14. To remove the sleeve from the main housing the 3mm dia. roll pin should be driven into the housing using a 2.5mm pin punch. (When rebuilding, a new pin must be used.) See Figure 17.



Figure 17



## Maintenance (continued)

15. Remove the Sleeve from the main housing to reveal the O-Ring seal. This seal should be carefully removed with a small pair of long nosed pliers & discarded. See Figure 18.



Figure 18

16. The product seal can be seen in the large end of the sleeve. This Seal should be carefully removed using a pair of long nosed pliers & discarded.



Figure 19

## Re-Build & fitment of New Service Repair Kit

The Service Repair Kit for the SSB Retractor unit is-

TE75P285-90 for standard EPDM seals. For units TE75P031 & TE75P051

TE75P285-94 for Perfluorolastomer seals. For units TE75P031-04 & TE75P051-04.

### 1. Fitting of Stem Product Seal Part No. TE75P543

Place the Stem Product Seal in the end of the Sleeve. Position the seal so that one side of the seal enters the seal groove. Carefully work around the seal, pushing it into the groove. Care must be taken not to kink the seal. See Figure .20



Figure 20

### 2. Fitting of Home Chamber/Sleeve Seal. Part No. TE75P540

Start one side of the O-ring in the O-ring Groove & gently stretch the O-ring into position. See Figure 21.



Figure 21

## Re-Build & fitment of New Service Repair Kit (continued)

### 3. Fitting the Sleeve into the Home Chamber.

Lightly wet the O-ring on the Sleeve with clean water & offer up to the Home Chamber. Rotate the Sleeve until the 3mm Spring Pin hole aligns with the hole on the Home Chamber.

Push the Sleeve into the Home Chamber & check that the Spring Pin holes align.

Place the Home Chamber on a piece of wood & tap the Spring Pin Part No. TE75P552 fully in using a pin punch.

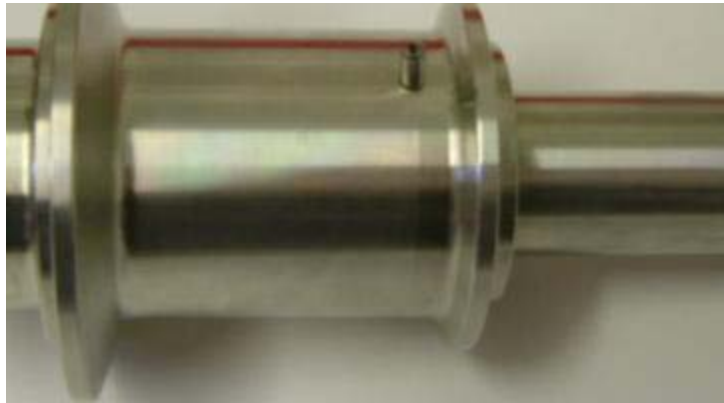

Figure 22

### 4. Fitting the Spray Stem.

Take the Spray Stem & ensure it is clean. Check down the 16mm bore to ensure that there is no scratching or scoring.

Carefully place the smaller threaded end of the stem through the Product Seal in the Home Chamber. Once aligned, gently tap the end of the stem with the palm of a hand to push the stem through the seal. See Figure 23.



Figure 23

## Re-Build & fitment of New Service Repair Kit (continued)

5. Fitting the Spray ball to the Spray Stem.

Ensuring it is clean, gently screw the Spray Ball all the way onto the Spray Stem. Slowly back off the ball on the thread until the small slot in the neck of the ball aligns with the hole in the Spray Stem.

Pass the Ball Securing Pin part No. TE75P555 through the neck of the ball & bend the end with a pair of pliers approximately 10° to prevent it falling out. See figure 24.



Figure 24

6. Fitting the Home Chamber/Stem Seal part No. TE75P538 or TE75P508.

Place the Home Chamber/Stem Seal part No. TE75P538 or TE75P508 into the O-ring groove in the cap of the Spray Ball. See Figure 25.



Figure 25

## Re-Build & fitment of New Service Repair Kit (continued)

### 7. Fitting the Spring.

Push the Spray Stem up so that the Spray Ball enters the Home Chamber.

If the Orientation Screw is required (if a targeted spray pattern is being used) rotate the Spray Stem until the M3 thread is visible through the guide slot in the Sleeve & screw in the Orientation Screw. Nip it up tight but take care not to over tighten as it is a fine thread.

See Figure .



Figure 26

### 8. Pass the Spring over the Spray Stem & Sleeve & ensure that the Spring is seated at the base of the sleeve. See Figure 27



Figure 27

## Re-Build & fitment of New Service Repair Kit (continued)

9. Fitting the Piston/Stem Seal Part No. TE75P541 or TE75P575.

Fit the Piston/Stem Seal into the Internal O-ring groove inside the bore of the Piston.

See Figure 28.



Figure 28

10. Fitting Piston Seal & Energising O-ring Parts TE75P586 & TE75P516 or TE75P546.

Put one side of the O-ring (TE75P516 or TE75P546) into the O-ring groove of the Piston & carefully stretch the O-ring into the groove.

Place one side of the Piston Media Seal Part TE75P586 into the groove on top of the Energising O-ring & carefully run the seal around the Piston so that it drops into the groove.

See 29.



Figure 29

## Re-Build & fitment of New Service Repair Kit (continued)

### 11. Fitting the Piston.

Stand the Retract-A-Ball assembly on the face of the Home Chamber so that the Spring points upwards. Place the Piston Spacer onto the Spring as shown. Place the Ring Magnet onto the Spring Spacer if required. The Magnet will only be required if Proximity Sensors are to be used to indicate open & closed positions. See Figure 30.

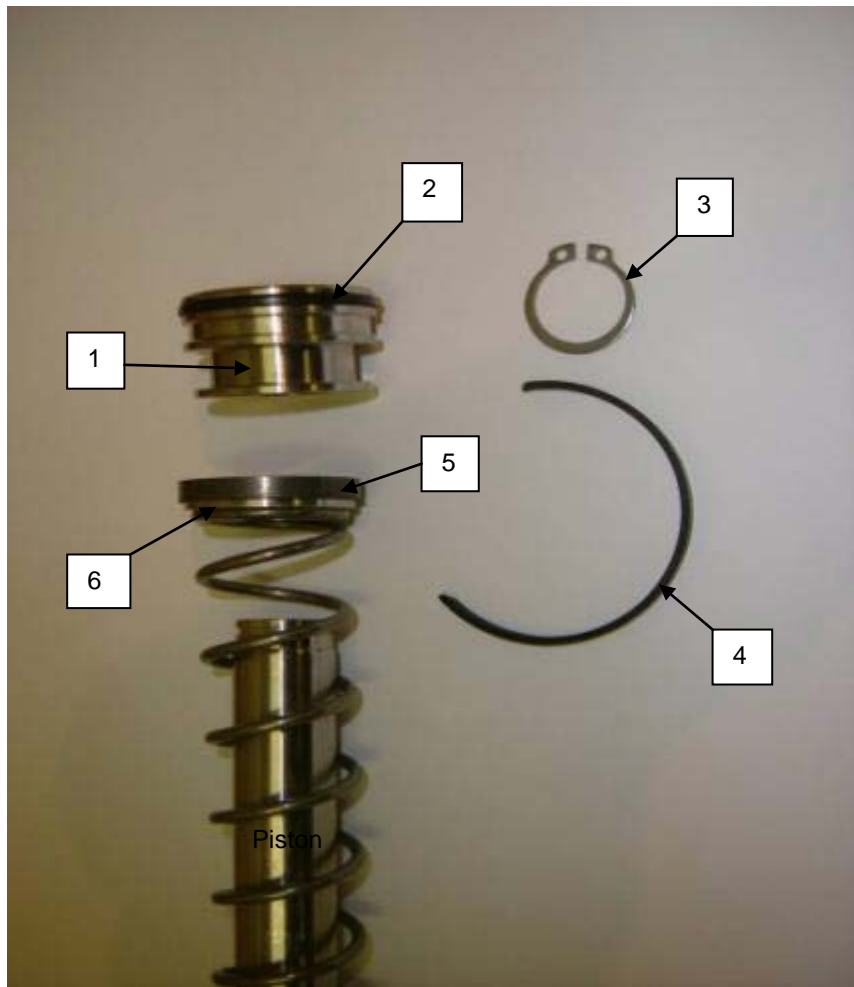

Figure 30

## Re-Build & fitment of New Service Repair Kit (continued)

12. Place the Piston onto the Piston Spacer & push downwards, compressing the Spring so that the Spray Stem enters the Piston. Push down until the Piston is fully seated.

**Warning:** DO NOT LET GO OF THE PISTON AS THE SPRING IS UNDER COMPRESSION.



Fit a new Circlip Part No. TE75P551 to retain the Piston. See Figure 31.



Figure 31

13. Fitting the Main Body Tube.

While the Unit is still stood vertically, place one of the O-ring Seals (TE75P511) over the Spring & lower into position on the Home Chamber Flange. Follow this with the Solid Gasket Spacer Ring followed by the second O-ring seal (TE75P511). See Fig 32.



Figure 32



## Re-Build & fitment of New Service Repair Kit (continued)

14. Ensure the Body Tube is clean & check the internal bore for scratches as this bore forms the air seal with the Piston.

Carefully lower the Body Tube over the Piston & Media Seal, take great care not to damage the Media Seal. Stop once the Seal has just entered the Body Tube & the groove for the Piston Slide Ring is still visible.

Wrap the Piston Slide Ring, part TE75P514 around the Piston groove & carefully lower the Body Tube until it meets the Solid Gasket Spacer ring on the Home Chamber.

Fit the DIN 40 Body Clamp to retain the two parts. See Figure 33.



Figure 33

15. Fitting the Home Chamber Spigot Seal Part No. TE75P538 (EPDM) or TE75P508 (Isolast) Carefully fit the O-ring in the O-ring groove at the front of the Home Chamber.

See Figure 34.



Figure 34

## Standard Service Kits

### Part Number TE75P285-90 For Units TE75P031 & TE75P051

The Standard Service Kit comprises of a full set of replacement seals, a new circlip and new roll pin. All the parts necessary to carry out a service or repair to the seals are included.  
The Standard Service Kit seal materials are EPDM and carbon filled PTFE.

| Standard Service Kit for Units TE75P031 & TE75P051, Part No. TE75P285-90 |                                 |      |
|--|---------------------------------|------|
| Part No.   | Description                     | Qty. |
| TE75P551   | External Circlip                | 1    |
| TE75P552   | Spring Pin                      | 1    |
| TE75P538   | Home Chamber/Spigot Seal (EPDM) | 1    |
| TE75P539   | Home Chamber/Stem Seal (EPDM)   | 1    |
| TE75P550   | Gasket-Home Chamber             | 1    |
| TE75P543   | Stem Product Seal               | 1    |
| TE75P540   | Home Chamber/Sleeve Seal (EPDM) | 1    |
| TE75P541   | Piston/Stem Seal (EPDM)         | 1    |
| TE75P514   | Piston Slide Ring               | 1    |
| TE75P586   | Piston Seal                     | 1    |
| TE75P516   | Energising O-Ring (EPDM)        | 1    |
| TE75P511   | O-Ring (EPDM)                   | 2    |
| TE75P555   | Ball Securing Pin               | 1    |

### Part Number TE75P285-94 For Units TE75P031-04 & TE75P051-04

However, if the unit was fitted with our 'Special Trim' seals required due to aggressive product or cleaning media, the service kit required is part number TE75P285-94.  
The seal materials are FFKM (Perfluoroclastomer) and carbon filled PTFE.

| Standard Service Kit for Units TE75P031-04 & TE75P051-04 "Special Trim"<br>Part No. TE75P285-94 |                                    |      |
|---|------------------------------------|------|
| Part No.  | Description                        | Qty. |
| TE75P551  | External Circlip                   | 1    |
| TE75P552  | Spring Pin                         | 1    |
| TE75P508  | Home Chamber/Spigot Seal (Isolast) | 1    |
| TE75P509  | Home Chamber/Stem Seal (Isolast)   | 1    |
| TE75P550  | Gasket-Home Chamber                | 1    |
| TE75P543  | Stem Product Seal                  | 1    |
| TE75P574  | Home Chamber/Sleeve Seal (Isolast) | 1    |
| TE75P575  | Piston/Stem Seal (Isolast)         | 1    |
| TE75P514  | Piston Slide Ring                  | 1    |
| TE75P586  | Piston Seal                        | 1    |
| TE75P546  | Energising O-Ring (Isolast)        | 1    |
| TE75P511  | O-Ring (EPDM)                      | 2    |
| TE75P555  | Ball Securing Pin                  | 1    |

## **How to order Spare Parts and Claim Procedure**

### **How to Order Spare Parts**

On the Cross Sectional Drawings as well as on all instruction drawings, the individual parts have a pos. no., which is the same on all drawings. From the pos. no. the part is easily identified in the Reference List of Parts, page 22.

Individual parts should always be ordered from the Reference Lists of Parts, page 22. Ref. no. and description should be clearly stated.

Please also quote the type of machine and serial no. This will help us to help you. The type and serial nos. are stamped on the Body of the tank cleaning machine.

### **Claim Procedure**

In case of failure that needs assistance from Alfa Laval Tank Equipment A/S, it is essential for our evaluation that the problem as well as the working conditions of the machine are described as detailed as possible.

For description of the working conditions, fill in copy of Claim Report - Working Conditions, which you will find at the back of this manual.

## **How to contact Alfa Laval Tank Equipment A/S**

For further information please feel free to contact:

Alfa Laval Tank Equipment A/S  
Baldershoej 19  
P.O. Box 1149  
2635 Ishoej  
Denmark

Phone no.: +45 43 55 86 00  
Fax no.: +45 43 55 86 01  
[www.alfalaval.com](http://www.alfalaval.com)

Contact details for all countries are continually updated on our websites.

## EC Declaration of Conformity

We

Manufacturer: Alfa Laval Tank Equipment A/S  
Address: Baldershøj 19, DK-2635 Ishøj  
Phone: +45 43 55 86 00  
Fax: +45 43 55 86 01  
E-mail: tankequipment.info@alfalaval.com

herewith declare that the below mentioned product:

### SSB Retractor Stroke 120 Media-to-Spring

|   |  |   |  |
|---|--|---|--|
| TE75P031<br>ATEX article index no. -70 or -80 | TE75P031-04<br>ATEX article index no. -74 or -84 | TE75P051<br>ATEX article index no. -70 or -80 | TE75P051-04<br>ATEX article index no. -74 or -84 |
|---|--|---|--|

is in conformity with the provisions of:

- The Machinery Directive 2006/42/EC, Annex II, Paragraph 1, Part A
- The Equipment explosive atmospheres (ATEX) Directive 94/9/EC.
- The Pressure Directive 97/23/EC
- FDA 21CFR§177

#### Harmonised European Standards:

The machine is manufactured in accordance with the relevant clauses of the following standards:

##### The Machinery Directive:

DS/EN ISO 12100-1, DS/EN ISO 12100-2, EN 1672-2

##### The pressure directive:

According to its own volume and the rated pressure range the product is regarded an Article 3, par. 3 Equipment.

# EC Declaration of Conformity

The ATEX-Directive:

DS/EN 1127-1, DS/EN 13463-1, DS/EN 13463-5

DS/EN ISO/IEC 80079-34, Annex A, paragraph A.5.3 Rotating machines

ATEX Certification:

EC Type Examination Certificate no. Baseefa11ATEX0231X

Marking:  II 1GD c T(Variable) Tamb -10°C to +140°C

 II 1GD c T(Variable) Tamb -10°C to +180°C

Note: (T)ambient rating: -10°C to +140°C when fitted with EPDM seals  
-10°C to +180°C when fitted with Perfluorolastomer seals.

Baseefa (2001) Ltd., Notified Body number 1180. Rockhead Business Park, Staden Lane, Buxton, Derbyshire SK17 9RZ, United Kingdom

Place: Ishoej, Denmark

Place: Ishoej, Denmark

Date: January 16, 2012

Date: January 16, 2012

Signature:



Signature:



Name and title: Henrik Falster Hansen  
R&D Manager

Name and title: Denniz Høxbroe  
ATEX responsible engineer

## ATEX-Special Conditions for safe use

### ATEX CERTIFICATION

 II 1GD c T(Variable) Tamb -10°C to +140°C

 II 1GD c T(Variable) Tamb -10°C to +180°C

BASEEFA CUSTOMER REFERENCE No. 5322

PROJECT FILE No. 11/0682

### Special Condition for Safe Use

1. The Unit shall be connected to a fully earthed pipeline/duct or tank/vessel.
2. The pipeline/duct shall not exceed a diameter of 3m, and the tank/vessel shall not exceed 100m<sup>3</sup>.
3. The air operated unit shall only be operated with inert gas or clean air.
4. The unit shall only be purge using inert gas or clean air.
5. Do not allow the unit to be operated when process media is in the pipeline or tank.
6. Do not allow the air pressure to exceed 5.5 Bar.
7. Do not allow the cleaning media to exceed 4 Bar.
8. When an external sensor is fitted to indicate the open or closed position it shall be suitable for the zone of use.

This product fully complies to ATEX category 1 as long as the 8 special conditions above are adhered to.

Please read the above conditions prior to installation & ensure that all conditions are met.

### Explanation of T (temperature) rating.

The ATEX classification

 II 1GD c T(Variable) Tamb -10°C to +140°C when fitted with EPDM seals

 II 1GD c T(Variable) Tamb -10°C to +180°C when fitted with Perfluorolastomer seals

Shows the temperature rating as T(Variable).

This is because the SSB Retractor max temperature that it will reach will be dependent upon the temperature of the production process or the temperature of the CIP media which passes through it.

**How to contact Alfa Laval**

Contact details for all countries are continually updated on our website.

Please visit [www.alfalaval.com](http://www.alfalaval.com) to access the information directly.

© Alfa Laval Corporate AB

This document and its contents is owned by Alfa Laval Corporate AB and protected by laws governing intellectual property and thereto related rights. It is the responsibility of the user of this document to comply with all applicable intellectual property laws. Without limiting any rights related to this document, no part of this document may be copied, reproduced or transmitted in any form or by any means (electronic, mechanical, photocopying, recording, or otherwise), or for any purpose, without the expressed permission of Alfa Laval Corporate AB. Alfa Laval Corporate AB will enforce its rights related to this document to the fullest extent of the law, including the seeking of criminal prosecution.