



*Setting Innovative  
Standards*

**M PUMPS SRL**  
Via dell'artigianato, 120  
45015 Corbola (RO) – Italia  
Tel. +39 0426 346304  
Fax + 39 0426 349126  
info@mpumps.it

**MAGNETIC DRIVE PUMPS**  
**API 685 Standard, OH5 vertical centrifugal**  
**mag drive, metallic pumps**  
**CN MAG-MV series**

*INSTALLATION, OPERATION AND MAINTENANCE  
INSTRUCTIONS*

*The present instruction are a translation of the original manual;  
Keep it together to the original Italian manual.*



**CAUTION**

These instructions are intended to qualified personnel that will:

- install the pump;
- use the pump;
- carry out maintenance / repair of the pump.

Read carefully this instruction manual before using the pump.



## CONTENTS

<b>1. GENERAL WARNINGS AND SAFETY .....</b>	<b>6</b>
<b>2. WARRANTY .....</b>	<b>7</b>
<b>3. NAMEPLATE.....</b>	<b>7</b>
<b>4. PUMP DESCRIPTION.....</b>	<b>9</b>
<b>5. TECHNICAL DATA.....</b>	<b>9</b>
<b>6. ALLOWABLE NOZZLE LOADS.....</b>	<b>10</b>
<b>7. OPERATING AND PERFORMANCE LIMITS.....</b>	<b>11</b>
<b>8. OVERALL DIMENSIONS.....</b>	<b>12</b>
<b>9. NOISE AND VIBRATION .....</b>	<b>12</b>
<b>10. IONIZING RADIATION.....</b>	<b>12</b>
<b>11. CHECKS TO PUMP DELIVERY, STORAGE .....</b>	<b>12</b>
<b>12. SHIPPING AND HANDLING .....</b>	<b>12</b>
<b>13. ASSEMBLY, INSTALLATION, CONNECTIONS, COMMISSIONING AND SETTING .....</b>	<b>13</b>
13.1. Assembly .....	13
13.2. Connection of the pump to suction and discharge pipes.....	13
13.4. Checks for the proper operation .....	14
13.5. Commissioning and operator training.....	14
13.5.1. Self-priming pumps and non self-priming pumps .....	15
13.6. Coupling the pump to the motor.....	15
13.7. Features and installation of pump and motor assembly.....	15
<b>14. INTENDED USE OF THE PUMP. IMPROPER USE. DESCRIPTION OF FUNCTIONING.PERSONAL PROTECTIVE EQUIPMENT DURING USE .....</b>	<b>15</b>
14.1. Intended use of the pump.....	15
14.2. Instructions for proper use reasonably foreseeable.....	15
14.3. Not permitted use.....	15
<b>15. RESIDUAL RISKS AND PROTECTION MEASURES TO BE TAKEN.....</b>	<b>16</b>
15.1. Description of the residual risks .....	16
15.2. Protection measures to be taken by the user and instructions .....	16
15.3. Personal protective equipment to wear .....	16
<b>16. OPERATIONAL LIMITS, DESCRIPTION OF HAZARDS NOT ELIMINATED FROM THE SAFETY MEASURES TAKEN.....</b>	<b>17</b>
16.1. Safety information present on the pump .....	17
16.2. Recovery mode .....	18
16.3. Fire-fighting equipment to be used: .....	18
16.4. Emission / dispersion of harmful substances.....	18
<b>17. MALFUNCTIONING, FAILURE, BREAKDOWN, ACCIDENT. MOST FREQUENT PROBLEMS: CAUSES AND REMEDIES ..</b>	<b>18</b>
17.1. Malfunctioning.....	18
17.2. Failure .....	18
17.3. Breakdown.....	18
17.4. Accident.....	18
17.5. Most frequent problems: problems, causes, remedies, residual risks.....	18
<b>18. PERIODIC AND EXTRAORDINARY MAINTENANCE .....</b>	<b>21</b>
18.1. Cleaning components and magnet .....	21
18.2. Periodic preventive maintenance .....	21
18.2.1. Emptying of the fluid contained in the pump .....	22
18.2.2. Emptying the oil contained in the pump.....	22
18.3. Extraordinary maintenance.....	22
<b>19. REPAIR AND PARTS REPLACEMENT.....</b>	<b>23</b>
<b>20. PERIODIC AND EXTRAORDINARY MAINTENANCE .....</b>	<b>23</b>
20.1. Pump disassembling .....	23
20.2. Pump reassembling .....	24
<b>21. DECOMMISSIONING, DISMANTLING AND DISPOSAL OF MATERIALS .....</b>	<b>24</b>
21.1. Decommissioning.....	24
21.2. Demolition and dismantling .....	24
<b>22. EXPLODED VIEW PART LIST .....</b>	<b>24</b>
<b>23. NOTES .....</b>	<b>25</b>
<b>24. APPENDIX A – Register of maintenance and periodic checks of the pump .....</b>	<b>26</b>





---

THIS INSTRUCTION MANUAL is intended to guide those responsible for the installation, operation and maintenance of *M PUMPS* CN MAG-MV series seal-less magnetic drive pumps. Please read it carefully, before you install and operate your *M PUMPS* pump. Useful information can also be obtained from: - Hydraulic Institute Standards (USA) regarding pump installation.

## 1. GENERAL WARNINGS AND SAFETY

This manual has been prepared by *M PUMPS* pump to provide the user all necessary information for its proper use and regular maintenance. Together with this manual you will find the manual of the electric motor when the pump is supplied with motor.

For health and safety at the workplace and to ensure a fair and sustainable use of the pump, the manual should be kept for any consultation.

**As part of the pump, this manual must be kept at all times.**

For any data not included or not deductible from this manual it is recommended that you contact *M PUMPS*.

**Do not use the pump before you have read and assimilated all safety rules and instructions in this manual.**

In case of damage or loss of the manual, ask for a copy to *M PUMPS* immediately.

The failure to follow instructions in this manual exempt *M PUMPS* from any liability.

The pump and the instructions are intended for operators who make professional use and should be used by qualified personnel adequately trained, aware of application, operation and risk that the pump generates during its use, the user with experience is the best form of qualification.

*M PUMPS* reserves at any time the right to make changes deemed necessary to improve the pump, taking care to update this manual as soon as possible. This reflects the state of the art when the pump was sold. In case of transfer of the pump, the user is encouraged to report to *M PUMPS* the address of the new owner to facilitate the transmission of any additions to the manual to the new user.

*M PUMPS* reserves all rights to this manual, no total or partial reproduction is allowed without written permission.

### Symbols used in the manual

Along the manual will be found warning signs to indicate possible dangerous and risky situations. These safety warning signs consists in a symbol and the respective warning.

#### MAGNETIC



Persistence of a magnetic field. This field may represent an immediate danger to individuals who have electronic medical devices, metal heart valves, metal or any other metal objects, impairing its functionality.

*M PUMPS* declines any responsibility for any damages to people who did not keep a safe distance of at least one meter, where it is shown that symbol.

#### DANGER



Indicates a potential risk to operators who are using the pump and / or the integrity of the pump, which could result in damaging itself and / or serious injury to people concerned.

#### CAUTION



Demands full attention to important details that the staff must know and keep in mind for the proper use and operation of the pump.

#### PROHIBITION



Demands full attention to operations or manipulations that are absolutely forbidden, not respecting the prohibition may damage the pump and / or operators.

Failing to observe these prohibitions releases *M PUMPS* of any responsibility for damages to things and/or people.

## 2. WARRANTY

Valid for one year from the date of the pump sale. *M PUMPS* do not assume any liability for any warranties explicit or implied, nor as regards the possibility to sell or the suitability of the items supplied.

The warranty will not be applied if:



- the repair and / or maintenance was not carried out strictly in accordance with the instructions;
- the pump has not been installed and put into service as instructed;
- the repairs were not made by staff *M PUMPS* or were made without consulting *M PUMPS*;
- not original spare parts were used;
- used lubricants were different from those recommended;
- the parts supplied were not used according to their nature and / or destination;
- the parts supplied were used carelessly, negligently, improperly;
- the parts supplied were damaged due to external circumstances.

All wear parts are excluded from warranty.

## 3. NAMEPLATE

The pump for installation in ordinary environments has the nameplate on the side of the support as shown: only the compiled fields must be considered relevant and therefore valid for identification.

### -PUMP UNIT SUPPLIED WITH ELECTRICAL MOTOR:

	<p><b>M PUMPS SRL</b>          Via dell'artigianato, 120          45015 Corbola (RO) – Italia          Tel. +39 0426 346304          Fax + 39 0426 349126          www.mpumps.it          info@mpumps.it</p>		
MOD.:	_____	S.Nr.:	_____
Q.:	_____ (mc/h)    H _____ (m)	Year:	_____
Mot.:	_____ rpm    P _____ (kW)	Item Nr.:	_____
Impeller D.:	_____		

### -PUMP UNIT SUPPLIED WITHOUT ELECTRICAL MOTOR:

	<p><b>M PUMPS SRL</b>          Via dell'artigianato, 120          45015 Corbola (RO) – Italia          Tel. +39 0426 346304          Fax + 39 0426 349126          www.mpumps.it          info@mpumps.it</p>		
MOD.:	_____	S.Nr.:	_____
Q.:	_____ (mc/h)    H _____ (m)	Year:	_____
Mot.:	_____ rpm    P _____ (kW)	Item Nr.:	_____
Impeller D.:	_____		

The serial number of the pump, here called "serial number" (s.nr) defines the type of components installed in the pump:

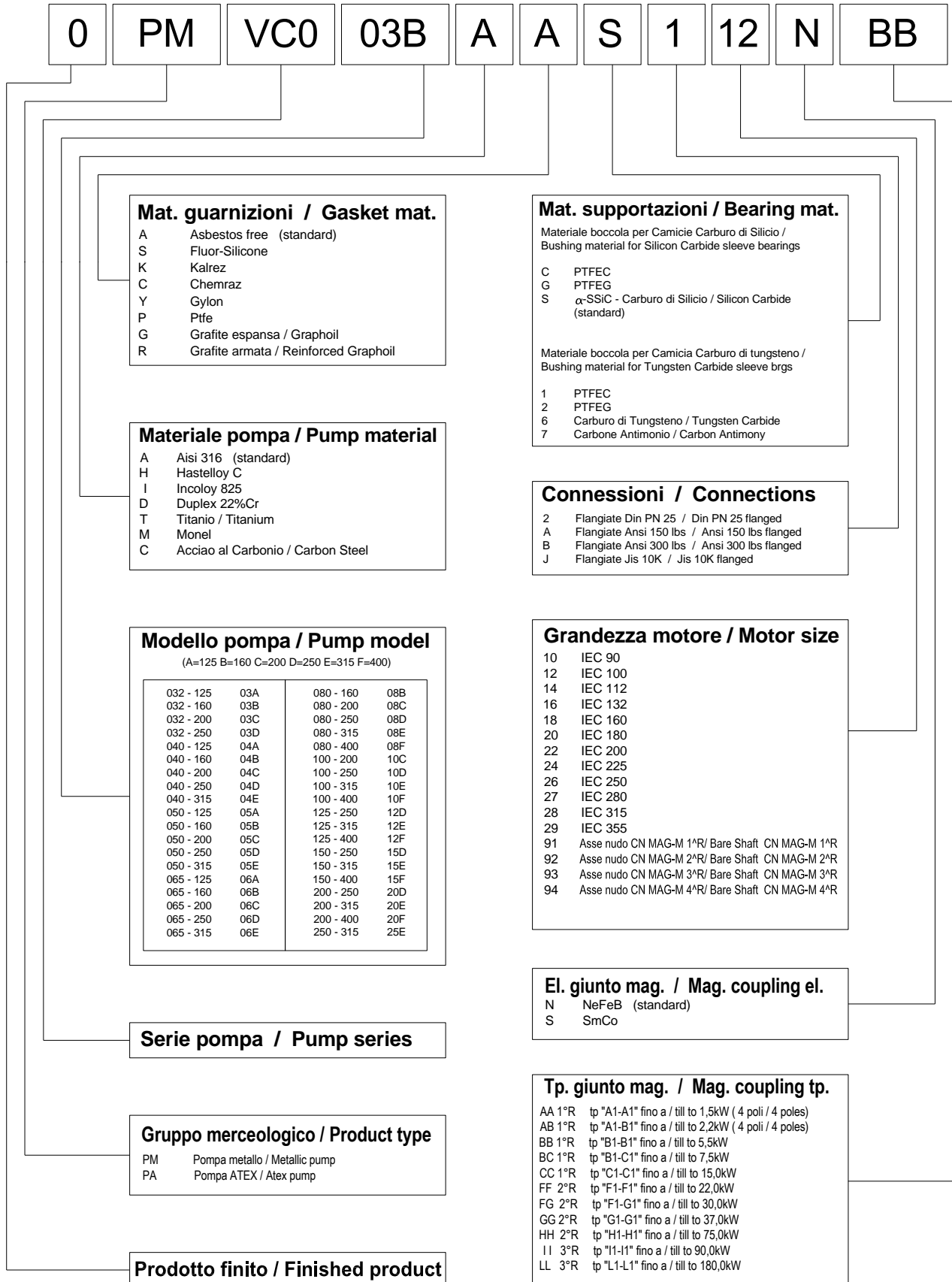



#### 4. PUMP DESCRIPTION

Key feature of magnetic drive pumps is that the fluid that has to be pumped never comes into direct contact with engine parts, ensuring the physical separation between the motor and the pump and the transmission is delivered via a coaxial magnetic coupling.

The pump consists of a part (outer rotor) that is coupled to an electric motor through elastic coupling (bare shaft version) or directly (close coupled) and a part (internal rotor integral with the pump impeller) that allows fluid pumping. The outer rotor consists of a series of magnetic elements with variable features and size suitable to the torque to be transmitted. The inner and outer rotor magnets are a magnetic circuit, characterized by overlooked opposite polarity pairs. At electric motor start, the outer rotor, when rotating, drives synchronously the internal rotor, thus the power is transmitted to the pump impeller, that explains the liquid pumping contained in the pump body. A static containment shell, called rear casing, located between the two rotors, separates the liquid from the atmosphere, making the pump hermetic.

##### Applications

- Generally this model is ideal for clean liquids slightly contaminated, without particles that can be magnetized;
  - The maximum working pressure of the plant, the allowable temperature and the maximum rotation speed depends on the type of pump and it is specified in the "TECHNICAL DATA" paragraph.
- Other uses are not allowed as the conditions of use stated in the "TECHNICAL DATA" paragraph must be respected in full. Using the pump in a plant or in liquid conditions different from those for which the pump was designed, can lead to dangerous situations to the user.

#### 5. TECHNICAL DATA

The pump described in this manual has the following characteristics:

Available in bare shaft configuration or close coupled, with the motor directly mounted in the pump support.

##### CN MAG-MV

- Nozzle: ANSI 300lbs flanged;
- Max viscosity: 200 cps;
- Max system pressure:
  - 52 BAR (standard, CN MAG-MV)
  - 95 BAR (HP version,)
  - 152 BAR (special version on request)
- Flow up to 4000 mc/h;
- Head up to 220 m;
- Working temperature up to +250 °C (std. Version), from -100°C to 450°C for special version
- Installed motor power: from 5,5kW to 500kW;
- Speed: up to 3500 rpm;
- Weight (pump only): from 46 to 4500 kg;

Electric Motor characteristics:	Supply frequency: 50 Hz	Supply frequency: 60 Hz
2 poles	2900 rpm	3500 rpm
4 poles	1450 rpm	1750 rpm
6 poles	980 rpm	1150 rpm

##### CAUTION



- CAUTION: If the pump is driven by inverter, remain within the recommended limits of rotation

## 6. ALLOWABLE NOZZLE LOADS

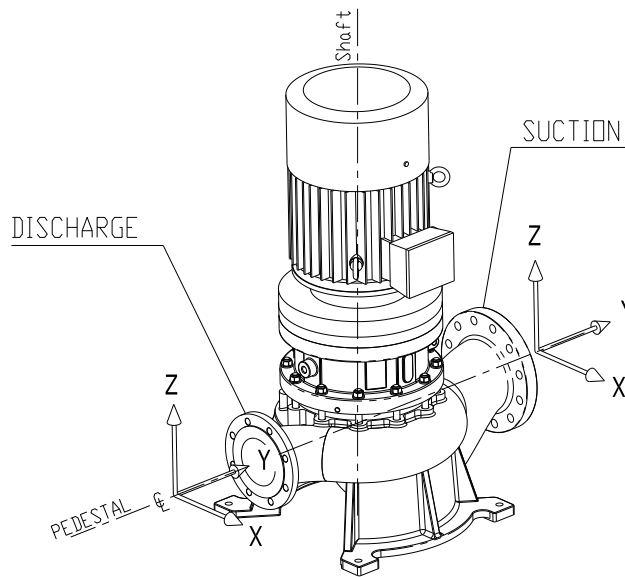

PUMP SIZE	Fx; Kg		Fy; Kg		Fz; Kg		MOMENTS;Kg.m		
	Suction	Discharge	Suction	Discharge	Suction	Discharge	Myz	Mxy	Mxz
2x1 1/2x5	120	75	120	75	250	160	65	65	68
2x1 1/2x6	120	75	120	75	250	160	65	65	68
2x1 1/2x8	120	75	120	75	250	160	65	65	68
2x1 1/2x10	120	75	120	75	250	160	65	65	68
3x1 1/2x5	130	80	130	80	270	180	78	78	80
3x1 1/2x6	130	80	130	80	270	180	78	78	80
3x1 1/2x8	130	80	130	80	270	180	78	78	80
3x1 1/2x10	130	80	130	80	270	180	78	78	80
3x2x5	165	115	165	115	320	220	95	95	100
3x2x6	165	115	165	115	320	220	95	95	100
3x2x8	165	115	165	115	320	220	95	95	100
3x2x10	165	115	165	115	320	220	95	95	100
3x2x13	165	115	165	115	320	220	95	95	100
4x3x5	215	135	215	135	440	275	100	110	115
4x3x6	215	135	215	135	440	275	100	110	115
4x3x8	215	135	215	135	440	275	100	110	115
4x3x10	215	135	215	135	440	275	100	110	115
4x3x13	215	135	215	135	440	275	100	110	115
6x3x6	260	165	260	165	510	320	120	130	140
6x3x8	260	165	260	165	510	320	120	130	140
6x3x10	260	165	260	165	510	320	120	130	140
6x3x13	260	165	260	165	510	320	120	130	140
6x3x16	260	165	260	165	510	320	120	130	140
6x4x8	260	215	260	215	510	430	125	137	150
6x4x10	260	215	260	215	510	430	125	137	150
6x4x13	260	215	260	215	510	430	125	137	150
6x4x16	260	215	260	215	510	430	125	137	150
6x6x10	290	270	290	270	580	550	137	145	155
6x6x13	290	270	290	270	580	550	137	145	155
6x6x16	290	270	290	270	580	550	137	145	155
8x6x10	350	290	350	290	650	580	145	160	163
8x6x13	350	290	350	290	650	580	145	160	163
8x6x16	350	290	350	290	650	580	145	160	163
8x6x20	350	290	350	290	650	580	145	160	163
8x8x13	400	350	400	350	750	650	150	165	170
8x8x16	400	350	400	350	750	650	150	165	170
10x8x13	440	380	440	380	780	670	160	180	190



**Note: for 33other pump sizes not present in this table, please refer to specific documents.**

**7. OPERATING AND PERFORMANCE LIMITS**

**CN MAG-MV**

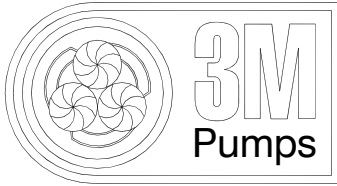

Curve a Schiera/Selection Chart  
 MODEL: CN MAG-M API 685 Curve N°:10706 Rev.:01

1450 RPM

US G.P.M.

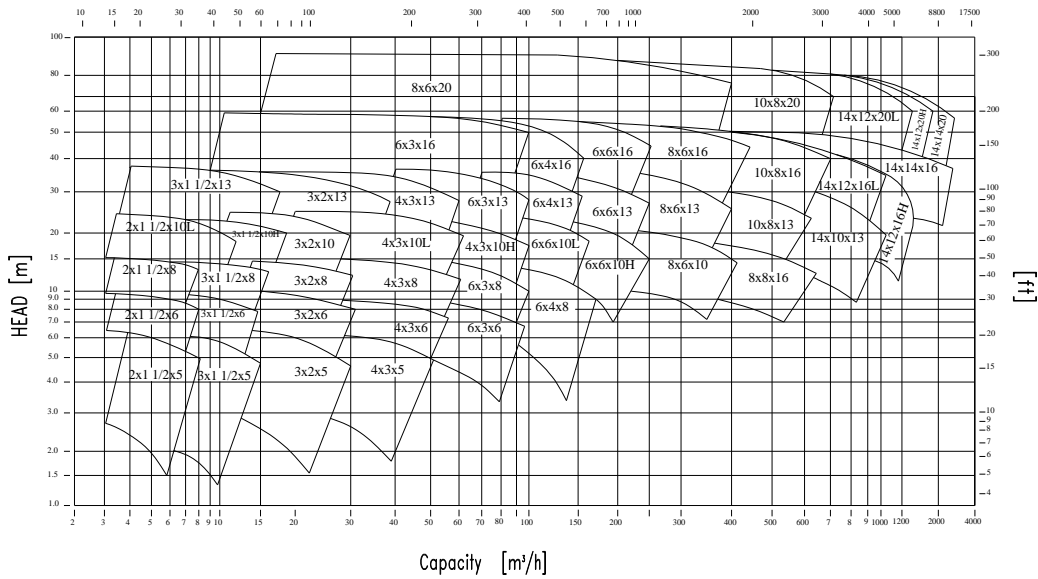

2900 RPM

US G.P.M.

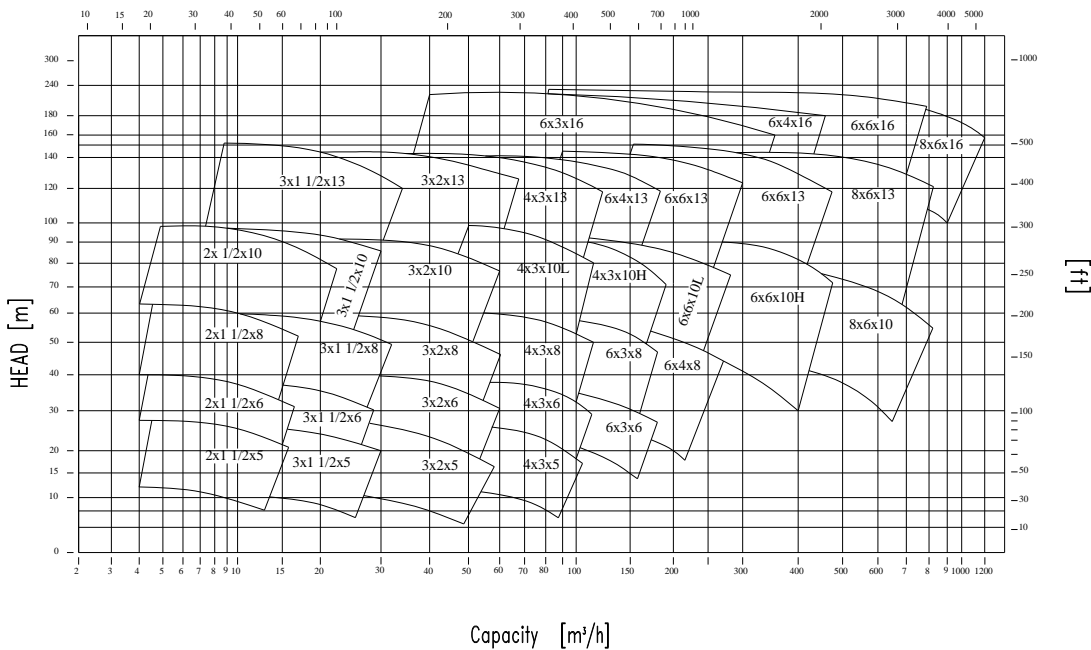

## 8. OVERALL DIMENSIONS

See specific documentation provided with this manual.

## 9. NOISE AND VIBRATION

The pump noise depends primarily on the operating conditions. The operating condition of the pump during the measurements is: pump coupled to an electric motor on a bench pumping liquid.

The average sound level measured frontally and laterally to the pump is below 85 dB (A).

## 10. IONIZING RADIATION

The pump does not emit any kind of ionising radiation that could endanger persons.

## 11. CHECKS TO PUMP DELIVERY, STORAGE

All *M PUMPS* pumps are tested before shipment and carefully packed for transport: at the reception of the pump make sure that the pump has not been damaged during the transport. If there are problems, contact immediately the carrier and inform *M PUMPS* about what happened.

So that the pump is preserved over time as best as possible, we recommend storing it away from the sun, bad weather and dust, if not immediately installed or used for long periods.

Suction and discharge connection safety plugs must not be removed until installation. If provided with electric motor, observe also the motor manufacturer's storage formality.

The maximum allowable temperature range during storage, preservation and use must be between -15 e +40 °C with humidity between 10 e 90%.

## 12. SHIPPING AND HANDLING

You should carry out a precautionary check when receiving the pump to detect and report any damage in the transport and handling operations . In case of damages do not proceed with any operation but contact immediately *M PUMPS*.

The precautions to ensure the stability of the pump concern the possible slips and overturning caused by handling and transport, which must be prevented by setting the pump casing of the pump with ropes to the vehicle frame.

Pump and motor assembly cannot be moved manually due to its high weight.

To move a pump positioned on a pallet, widen as maximum as possible the forks and then operate.

For a stable lifting the pump can be lift as indicated in the figures:

### Pump with motor

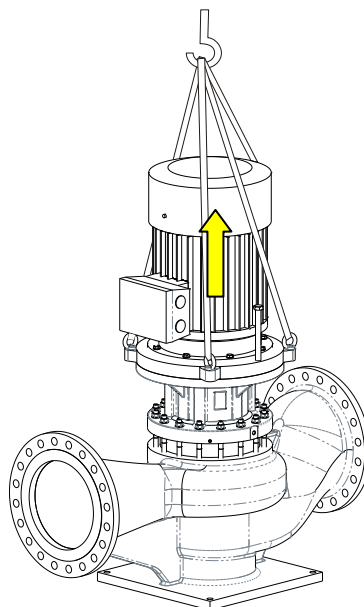

Centre of gravity approximately in the middle

These operations must be performed by a trained staff who is informed of the risk of these procedures.

**PROHIBITION**



- It is forbidden to lift the pump using different lugs from than those specially designed and reported, as points of anchorage.
- You can not lift a pump and motor assembly using the eye-bolt of the electric motor only.
- During the lifting the entire surrounding area is considered as a danger zone and must be cleared by personnel not engaged in those operations.

It is indicated the possibility of transporting and handling the pump using the lugs designed for that use: you must ensure that chains and shackles are able to withstand the weight of the pump (as shown in "TECHNICAL DATA").

### **13. ASSEMBLY, INSTALLATION, CONNECTIONS, COMMISSIONING AND SETTING**

#### **13.1. Assembly**

Install the pump on a solid foundation as close as possible to the pumped liquid source, below its level, in a position to facilitate maintenance and inspection.

Ensure that the pump does not take rough shacks as this may damage the magnets of the internal and external rotor or the silicon carbide bearings.

Ensure that the heated air from other units does not affect the pump; the air temperature must not exceed 40 °C, for higher temperatures contact your distributor *M PUMPS* ensure also cooling air free circulation area of at least  $\frac{1}{4}$  the motor diameter, because either the pump or the motor should be able to dissipate the heat by natural air convection. Insufficient cooling could lead to high surface temperatures of the bearings support, poor lubrication and premature failure of bearings. Monitoring of the surface bearings temperature is useful.

It is always responsibility of the operator to keep limited the temperature of the liquid to avoid pump superheating: in case of irregular pressure fluctuations and flow drop turn off the pump.

**CAUTION**



- Normally you should mount the pump horizontally. If mounted vertically or inclined, the pump, or rather the suction flange, shall be placed in the lowest point. Leave a space of at least 50 cm between the pump and any walls or pipes.
- When pumping liquid can reach high temperatures: from 60 °C upwards you must install protections to prevent contact with hot pump parts;
- Connect to the ground the entire pump casing to prevent accumulation of static electricity;
- If the pumped liquid can be dangerous to people and environment, the user must take precautions for a simple and quick block in case of leakage for breakage/ replacement/ pump maintenance.

#### **13.2. Connection of the pump to suction and discharge pipes**

For a proper installation aimed at an optimal use of the pump, you must follow these requirements:

- pipes must be supported and kept in line independently of the pump, until its connections, so that do not load on it;
- connections must not be subjected to stresses during operation;
- the maximum allowable forces and moments on flanges shall not exceed those listed in "technical data";
- inlet pipes should be built with as few restrictions as possible in order to have the highest available NPSH;
- the length of pipes , particularly that of the inlet pipe must be minimized;
- the pipe must be placed so that it is not possible the formation of air traps; if this is not possible, it should be calculated the possibility of bleeding the air from the highest point ;
- in the suction line use full section valves only;

- if the suction pipe is larger than the suction flange, you must use an eccentric reduction to the suction flange, in order to prevent formation of air traps and vortices;

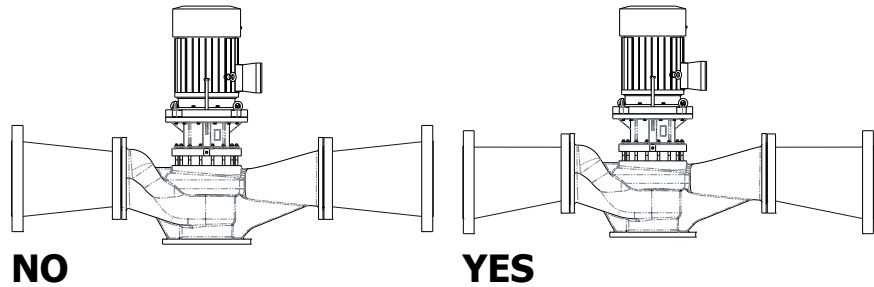

- If there is a possibility that the maximum working pressure can be overcome, for example due to excessive suction pressure, appropriate measures should be taken by including a safety valve in the pipe;
- Avoid using quick-closing valves, because sudden changes of pressure cause water hammer very dangerous for the pump and the pipes;
- Before installing the pump, make sure that the suction line is clean and/or provided with a filter to protect the impeller and the bearings from damages incurred by slag, or other foreign particles, especially when you start the installation for the first time.

### 1.3. Electrical connections:

#### **DANGER**



The pump is **supplied with or without electric motor: only qualified personnel** should carry out mechanical connection of the pump to the motor (for the model without motor) and the electrical connections of the motor to the electrical system. Please read carefully the instructions manual of the manufacturer of the motor or the manual before you complete the installation.

Make sure that the motor can not be started during maintenance jobs.

### 13.4. Checks for the proper operation

We recommend to **install a pressure gauge** on both inlet and outlet pipes to allow the operator to easily control the proper pump operation in relation to the required operating point: in case of cavitation or other malfunctions, there will be obvious pressure fluctuations.

Check the differential pressure of the pump between the suction and discharge connections to verify that it works in the required working point.

Check that the absolute pressure at suction is not as low to cause cavitation.

#### **CAUTION**



Pump suction absolute pressure (in m) must be at least 0,5 to 1 m higher than the vapour pressure of the pumped liquid, in order to avoid cavitation. Cavitation must always be avoided as it is very dangerous for the structure of the pump.

### 13.5. Commissioning and operator training

- Fully open the inlet valve and fill the pump and suction line;
- Ensure there are no obstacles to the free rotation of the pump impeller.

*MPUMPS* series CN MAG-MV **are not reversible** so the rotation can not be reversed.

The proper **direction of rotation is counter clockwise**: seen from the pump casing, an arrow indicates the correct direction of rotation; reversing the direction of rotation may cause damages to the pump.

To control the direction of rotation, start and stop immediately the electric motor, then observe the direction of rotation



Make sure that rotating parts, such as flexible coupling or other related organs, are always protected when the pump is running.

Operators using the pump must have read this manual in the sections committed to the functioning, use and maintenance, as well as being qualified to fully understand the features and to be able to identify the problems of the pump.

By carrying out the functions mentioned in the previous section and all controls listed in the register maintenance, the pump is ready for use.

### **13.5.1. Self-priming pumps and non self-priming pumps**

CN MAG-MV pumps are not self-priming: make sure that the pump is filled with liquid and if necessary, vented before starting; in case that the suction head is negative compared to the discharge , the dry run should be avoided.

### **13.6. Coupling the pump to the motor**

Series CN MAG-MV pumps are directly close couple type.

No elastic couplings and spacers required.

For coupling motor to the pump assembly, please refer to maintenance procedure ISM0043.

### **13.7. Features and installation of pump and motor assembly**

The shafts of the pump and the motor have already been adjusted and aligned as an extension of one another.

For installation in the plant it is necessary to respect the following sequence:

- The baseplate must be anchored to an horizontal base, using also thickness;
- Tighten the nuts of the bolts;

## **14. INTENDED USE OF THE PUMP. IMPROPER USE. DESCRIPTION OF FUNCTIONING. PERSONAL PROTECTIVE EQUIPMENT DURING USE.**

### **14.1. Intended use of the pump**

The magnetic drive pump, thanks to the separation between the pump and the motor, never enters into direct contact with motor parts, providing a friction effect on the impeller of the pump. The pump works correctly if the parameters specified in the paragraph "TECHNICAL DATA" are followed.

### **14.2. Instructions for proper use reasonably foreseeable**

Before starting to operate you must check that:

- All maintenance actions were properly carried out according to the time intervals set by *M PUMPS*;
- There are no damaged parts of the pump;
- All the warning stickers and safety plates are present and in good condition and are operating the emergency stop buttons (check through a test).

#### **CAUTION**



At the start, immediately check the pressure gauge placed in the discharge: if the discharge pressure does not reach the nominal value quickly, stop the pump and try to start again. Check the pump and piping to make sure that there is no leakage of liquid from the plant. A noisy pump is a symptom of a malfunction that will mean a failure in the short term. A very low frequency noise with a rumble can indicate cavitation; an excessive noise of the motor can be caused by a wear of a bearing.

### **14.3. Not permitted use**

Even maintaining the conditions of use indicated in the paragraph "TECHNICAL DATA", the ways in which the pump should not be used are given here. To avoid damaging the pump, it is forbidden to use it in the following conditions:



**PROHIBITION**



- Start the pump dry: the pump casing must be full of liquid.
- Run the pump dry for more than one minute;
- Run the pump work with inlet valve and /or outlet closed: the heat generated by the impeller, by magnetic coupling and bearings will bring liquid to boil, which will cause pump cavitation/vibration, impeller damaging and bearings collapse;
- The pump flow must never be throttled by the valve located in the suction pipe, which must be kept fully open;
- Start the pump if there are leakages;
- Change working condition of the pump without having consulted *M PUMPS* technical office;
- Loosen pump connections while pump under pressure;
- Try to clean the pump while it is running;
- Run the pump in the opposite direction to that shown in the pump casing;
- Run the pump over nominal temperature and pressure;
- Pumping liquids containing ferromagnetic particles of any size, or substances that can attack chemically or erode the inside of the pump;
- Remove guards and shelters while the pump is running;
- Make any intervention on the pump organs
- Make any intervention on electrical parts installed without first cutting electric power off, do not alter the safety devices installed, do not activate repeatedly the command buttons.

**DANGER**



It is incorrect any use of the pump other than that mentioned in the paragraph “Instructions for a proper use reasonably foreseeable”.  
*M PUMPS* disclaims any liability damages to things and people related to uses for which the pump was not specifically designed and constructed.

It is also forbidden to use the pump in a way that, based on experience and under certain situations, may result dangerous situations due to an improper use of the pump.

**15. RESIDUAL RISKS AND PROTECTION MEASURES TO BE TAKEN**

**15.1. Description of the residual risks**

Despite adopted measures incorporated in the pump, the main dangers associated with the use of the pump and the solutions identified are the following:

- Danger of spray projection of process fluid that can be corrosive or burning, as a result of improper installation and sudden ruptures of the pump casing and hydraulic lines;
- Danger of cuts to the hands due to the presence of smears on the pump casing;
- Explosion of the pump due to a formation of explosive mixture inside the pump casing as a result of an improper use.

**15.2. Protection measures to be taken by the user and instructions**

**PROHIBITION**



**It is absolutely forbidden to the user to tamper safety devices.** Before using the pump check the proper couplings mechanical protection. Any tampering cancels the warranty and liability of *M PUMPS* in front the pump users.

Only authorized maintenance personnel can perform maintenance operation affecting safety devices.

**15.3. Personal protective equipment to wear**

Protection measures that have to be taken during this phase are: use of antacid and antistatic clothing, chemical-resistant glasses, mechanical and chemical protecting gloves and safety shoes.

Avoid the use of accessories (necklaces, bracelets, etc.) and unshackled, torn or dangling clothes that could get entangled in parts of the structure.



## 16. OPERATIONAL LIMITS, DESCRIPTION OF HAZARDS NOT ELIMINATED FROM THE SAFETY MEASURES TAKEN

Dangers that have not been reduced/eliminated with the safety measures adopted on the pump can be reduced/eliminated if operators apply management measures such as :

- Keep all the safety warnings of and all stickers and labels intact and replace them when necessary, periodically checking their good condition;
- Do not consume substances which may affect the physical ability or the mental faculty (alcoholic beverages, medicines, drugs, etc);
- Always use original spare parts or components approved by *M PUMPS*;
- Always perform any modification or structural intervention without the approval of *3MPUMPS*;
- After accidental shocks suffered by the pump, check the pump integrity and perform a check to *M PUMPS*;
- after a long shut down period of pump, check pump integrity and wearing parts status. If necessary replace them with original spare parts .

### CAUTION





Each of the misuse or negligence listed up to now causes:

- immediate cancellation of *M PUMPS* warranty.
- cancellation of *M PUMPS* responsibility for damage to property, animals or people.

### 16.1. Safety information present on the pump

Safety warnings applied to the pump must be respected and restored in case of illegibility, and are as follow:

Warning	Description signs applied	Symbol/indication	Quantity	Notes
1.	<i>M PUMPS</i> nameplate.	As described in paragraph "PLATE"	1	1
2.	Label rotation and do not run dry indication		1	2
3.	Hydro-test label		1	3
4.	Label quality control assembly		1	Internal use

### INSTRUCTIONS AND PROCEDURES FOR THE TRAINING OF THE PERSONNEL AND FOR EMERGENCIES

Operators responsible for the various life stages of the pump must be:

- for assemblers: staff formed and trained on good practices for handling of goods with the use of tools and lifting equipment;
- for installers of pipes and electrical connections: qualified and trained staff to operate on electrical plants, staff with experience in hydraulic installations;
- for users: professional staff trained in the instruction for use of this pump.

In case of emergency:

- alert who is close to the situation of danger, even waving his arms;
- stop the pump by pressing the nearest emergency stop button;

## **16.2. Recovery mode**

To return to normal operating conditions, you must identify and eliminate all causes that have provoked the emergency, eventually repairing or replacing the components that may have been damaged.

### **CAUTION**



**After the intervention on protection devices, it must be found the cause that provoked it before continuing to operate.**

## **16.3. Fire-fighting equipment to be used:**

In case of fire involving the pump, you can use water or liquid foam or powder type fire extinguisher, but only after shutting off electric power. Do not use CO<sub>2</sub> as sprayed at -79 ° C may react violently with hot parts.

## **16.4. Emission / dispersion of harmful substances**

The fluid in the plant might be released in the atmosphere following an intervention or the pump break.

## **17. MALFUNCTIONING, FAILURE, BREAKDOWN, ACCIDENT. MOST FREQUENT PROBLEMS: CAUSES AND REMEDIES**

### **17.1. Malfunctioning**

There are not pump components that may lead to cases of pump malfunctioning as to restrict or make its use dangerous.

In paragraph "Most frequent problems: causes and remedy" is discussed in details in this section.

### **17.2. Failure**

In case of failure of mechanical parts you must immediately restore the original terms of security by replacing or repairing the parts that have deficiencies.

In case of failure of the pump, proceed as follows:

- Turn the motor off;
- Close the inlet and outlet valves;
- Find the cause of the failure by checking the section " Most frequent problems: problems, causes, remedies, residual risks".

The failure of a pumping plant can be attributed to:

- a pump failure;
- a failure or defect in the piping;
- a failure due to a miss-installation or a start up not correctly made;
- wrong choice of pump.

### **17.3. Breakdown**

In the event of failure of pump alert verbally the staff present in the nearness of the damage that is verifying.

### **17.4. Accident**

In case of accident, you must report the emergency to the plant manager responsible of the installation, in order to secure the plant and allow the emergency team to reach the place where the accident happened.

## **17.5. Most frequent problems: problems, causes, remedies, residual risks**

<b>INSUFFICIENT FLOWS</b>	
<b>Causes</b>	<b>Remedies / actions to be taken</b>
The required head exceeds the designed pump head.	<p>Increase the speed rotation if possible.            Fit an impeller of greater diameter            Reduce the total head of the system if possible.            Increase the diameter of the discharge pipe.            Check that the discharge valve is fully open.            Replace the pump.            Ask for advice to your <i>M PUMPS</i> distributor.</p>
The pump rotate in the opposite direction.	<p>Check the direction of rotation.            Refer to section 3.5 of this manual</p>
Air or steam trapped in the suction.	<p>Check the presence of air or steam trapped. Refer to section 3.4 of this manual.</p>
The liquid contains air or steam. The liquid produces foam.	<p>Check the presence of vortices in the suction line. Enter some in the fuel tank to prevent the formation of vortices.            Install a tank of sufficient capacity in the suction line to allow gas to drag.</p>
Insufficient inlet pressure, with the generation of cavitation and efficiency loss.	<p>Reduce negative suction head, increase static suction height            Check that the intake is not blocked or are no bottlenecks.            Reduce liquid temperature.            Increase suction pipe diameter.            Reduce inlet pipe length.            Open the inlet valve fully.            Check the viscosity of the liquid, refer to "technical data" section of this manual.            Increase the temperature of the liquid if necessary.</p>
Wear on pump casing or impeller wear ring.	<p>Check the condition of rotating ring wear and collar. Replace if worn, refer to Chapter 10 of this manual.</p>
Liquid temperature close to boiling point	<p>Reduce liquid temperature.</p>
<b>NO FLOW</b>	
<b>Causes</b>	<b>Remedies / actions</b>
The pump is not primed	<p>Re-prime the pump. Refer to section 3.5.1 of this manual.            Check for air leaks in the suction line.</p>
Suction line blocked	<p>Ensure that there are no obstructions, blind pipes, or closed valves.</p>

The magnetic coupling decouples	<p>Reduce flow: partially close the discharge valve.          If possible reduce liquid specific gravity.          Reduce the pump head (check in advance with your distributor <i>M PUMPS</i>).          Make sure the pump turns freely, inspect the inside in case this does not happen.          Reduce installed motor power (check in advance with your distributor <i>M PUMPS</i>).          Adopt star-delta starting.</p>
Motor has stop	<p>Check power of the motor.          Check status of the motor.</p>

### EXCESSIVE FLOW

Causes	Remedies / actions
The head required is lower than that provided by the pump	<p>If possible, reduce rotation speed          reduce the impeller diameter; partially close the discharge valve .</p>

### OVERHEATING OR MOTOR STOP

Excessive liquid specific gravity.	Reduce flow by throttling discharge valve.
The pump has seized or is about to seize.	Check the free rotation of the impeller. Check for internal obstructions.
The motor and pump are misaligned.	Refer to section 3.8 of this manual.
The motor bearings are damaged or worn.	Replace the motor bearings, investigate the causes of breakage.
Motor under dimensioned.	Fit a powerful motor (check in advance with your distributor <i>M PUMPS</i> ).
Motor overload threshold set incorrectly.	Check motor safety settings.
The motor dry running (where present) has failed or has been set incorrectly.	Control flow decreases or lack of liquid in suction.

### FUNCTIONING WITH NOISE DEFECTS AND/OR VIBRATIONS

Causes	Remedies / actions
<p>Insufficient inlet pressure, consequent cavitation, insufficient lubrication of the bearings (with mechanical damages if the condition persists).</p>	<p>Refer to paragraphs 3.4, 3.5, 4.1, 4.2, 4.3 of this manual</p>
<p><b>STOP IMMEDIATELY THE PUMP!</b></p>	

Wear, erosion and immediate damage to the impeller and internal bearings.	Check inside the pump damages or obstructions.
Wear of the coupling motor-pump.	Replace the coupling and proceed to the realignment of pump and motor.
Ball bearings or motor failure.	Check and replace them if necessary.
Pump, motor or baseplate not anchored well..	<b>Make sure that the motor and baseplate are firmly anchored to foundations and do not produce any abnormal vibration.</b>
Misalignment or improper anchoring of the pipes.	Check correct alignment of pipes and supports, refer to section 3.2 of this manual.
The pump was started while still rotating in the opposite direction, for a previous start.	Stop immediately the pump and drain all the liquid from the discharge line before restarting.
<b>OVERHEATING OF EXTERNAL BEARINGS (bare shaft versions)</b>	
Lack of oil or wrong type of oil in the bearing frame.	<b>Check oil level: fill up or empty and replace it if necessary. Replace the bearings.</b>
Excessive oil temperature into the bearing frame.	Fill the bearing frame with oil as indicated in the paragraph to restore the correct working temperatures.

## 18. PERIODIC AND EXTRAORDINARY MAINTENANCE

Proper maintenance and correct use are essential factors to ensure performance and pump lifetime.

### 18.1. Cleaning components and magnet

To degrease and clean all surfaces of the couplings and centering surfaces, if possible use methyl alcohol. Preferably use paper towels. Do not use solvents and other corrosive liquids on magnet to avoid damaging it; any dirt can be removed from the magnets by using gummed paper. Do not hack or put pressure on the magnet during its handling, it would cause them damages because of their fragility.

### 18.2. Periodic preventive maintenance

Instructions relating to maintenance activities whose implementation does not require specific skills that can then be made by users of the pump, are given. These are programmed operations and inspections planned on issues considered important for technical, operational and staff safety purposes, based on *M PUMPS* experience and knowledge.

If the hydraulic pump is washed with pressure jet , prevent water entry into the motor terminal box

#### **DANGER**



Do not throw water on the pump hot components: components can explode in case of sudden cooling generating projection of metallic material and under pressure hot liquid leakage hazardous to health. Do not stroke and pressure on the bearings, you would cause the formation of micro-cracks which can cause serious damages.

N.	<u>Description control / intervention: implementation rules</u>	<b>Warnings and protective measures be taken to perform the maintenance properly and safely</b>	<b>Time</b>
1	Ball bearing frame	Fill up the oil until the middle of the level indicator plug	Weekly. Replace oil every 5,000 hours.
2	Internal bearings	Check the status of bushings, sleeve bearings and thrust bearings, replace them if worn	After 2500 hours, check any premature wear, then every 5,000hours or every year.
3	Wear rings	Check the status of the wear ring, consult the table of tolerances	After 2500 hours, check for premature wear, then every 5000 hours or every year.
4	Motor bearings	Unless other specifications, motor bearings are greased for life, so there is not a maintenance schedule, anyway it is recommended to check the condition of the bearings and replace them when worn	

In **Appendix A** is a list of periodic maintenance and inspections to be completed each time you perform such operations.

### **18.2.1. Emptying of the fluid contained in the pump**

Before disassembling, you must empty the liquid from the pump according to the following steps:

- Close the valves present in the inlet and outlet pipes, and in the cooling pipe;
- Unscrew the drain plug;
- When emptied, screw the drain plug again.

If hazardous to health liquids are pumped, wear suitable personal protective equipment before coming into contact with the liquid.

### **18.2.2. Emptying the oil contained in the pump**

If the pump is designed with oil lubricated bearing frame (bare shaft versions):

- Remove the oil drain plug;
- Drain the oil and collected it without dispersing into the environment;
- Replace the drain plug .

If there are fluids hazardous to health, wear personal protective equipment suitable before coming into contact with the liquid.

### **18.3. Extraordinary maintenance**

The extraordinary maintenance operations concern the activities that are beyond those typically programmable and executable; they require precise technical expertise by qualified personnel, and then is recommended to contact *M PUMPS*. Address is shown in the header of every page of this manual.

#### **DANGER**



If it becomes necessary to disassemble the pump, you must remember that the liquid should be collected and disposed in accordance to existing environmental laws. If the pump should be sent to *M PUMPS* it must be drained, cleaned and must not contain any traces of pumped liquid.

## 19. REPAIR AND PARTS REPLACEMENT

**The pump must always be kept in optimum operation conditions.**

Most of the spare parts have clear and comprehensive references for their identification. It is important that the pump components, in the case of repair, are replaced by original ones: to order original spare parts, contact *M PUMPS* referring to the model of the pump, serial number, description of the component and the quantity needed.

When you see elements with rust, cracks, etc, you must perform all replacements/repairs necessary to re-establish the safe operating conditions of the pump. In any case it is advisable to ask *M PUMPS* opinion before any intervention.

## 20. PERIODIC AND EXTRAORDINARY MAINTENANCE

The table below shows the information needed to determine the pump casing wear ring state of wear:

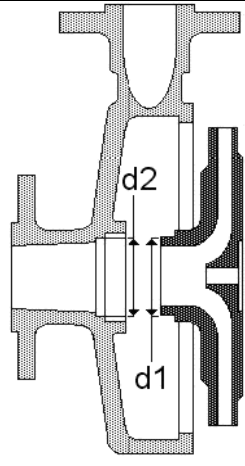
	PUMP MEASURES	DIAMETRICAL TOLERANCE ON STAINLESS STEEL	DIAMETRICAL TOLERANCE ON OTHER ALLOYS
	SUCTION NOMINAL DIAMETER [ mm ]	[ mm ]	[ mm ]
32, 40		0.45-0.55	0.25-0.35
50, 65, 80, 100		0.50-0.60	0.30-0.40
125, 150		0,55-0,65	0,35-0,45
200, 250, 300		0,75-0,90	0,65-0,80

	PUMP RANGE	SLEEVE BEARING MINIMUM SIZE - d4	STATIONARY BEARING MAXIMUM SIZE - d3	MAX ALLOWABLE CLEARANCE
			[ mm ]	[ mm ]
1^Range	/	/	/	/
2^Range	/	/	/	/
3^Range	/	/	/	/
4^Range	79,97-79,95	80,22-80,24	0,25-0,29	

### 20.1. Pump disassembling

If the pump has pumped hot liquids, make sure that it has been cooled before disassembly. The pump may have pumped liquid hazardous to health is therefore necessary to wear personal protective equipment.

Before to proceed with disassembling, follow carefully the decommissioning instructions, at paragraph 20.2.

The activities of disassembly and maintenance of the pump should be conducted in full compliance with current health and safety regulations. Some spare parts may have potential health risk to the operators:

**CAUTION**

*M PUMPS* disclaims any liability for damage to property and people and will invalidate the warranty if you install non original components.

**MAGNETIC**

The pumps built by *M PUMPS* contain extremely strong magnets. The use of tools and work surfaces not ferromagnetic is highly recommended. The department in which you perform maintenance must be clean and free of iron particles that may be attracted by magnets.

**Pay attention to the strong magnetic attraction** when you work in proximity of the internal or external magnets. Tools can be strongly attracted by magnets, or slip from the hands causing damages to fingers and hands, moreover, the magnets may be strongly attracted by ferromagnetic devices present in the area.

For dismantling and maintenance instructions, refer to specific documentation ( ISM0043).

**20.2. Pump reassembling**

To reassemble the pump, follow maintenance procedure (enclosed...) in reverse order. Clean each component before assembly, make sure that all parts are free from dirt, metallic particles, etc..

**21. DECOMMISSIONING, DISMANTLING AND DISPOSAL OF MATERIALS****21.1. Decommissioning**

For an eventual long time decommissioning, it is advisable to apply some simple precautions to preserve correctly the pump.

Make the pump run with clean water (or other suitable solvent compatible with the materials of the pump) for several minutes, in order to avoid the risk of liquid precipitation or deposits. Disconnect from the electric power / liquid supply and place it in a protected site.

During the commissioning after a long period of storing, carefully follow all recommendations for commissioning described at paragraph 3.5 of this manual.

**CAUTION**

A good storing procedure will guarantee against unpleasant incidents during the restarting of the pump. *M PUMPS* disclaims any responsibility for machines stored incorrectly. If you intend to stop using this pump it is recommended to make it inoperative.

**21.2. Demolition and dismantling**

The user must comply with the legislation on environmental conservation and will have to deal with the disposal and elimination of materials and harmful substances of the pump components. It is recommended to destroy the identification plates of the pump and any other document.

**22. EXPLODED VIEW PART LIST**

See attached documents.











M PUMPS s.r.l. Via dell'Artigianato, 120  
45015 - Corbola (RO) – Italy  
info@mpumps.it  
www.mpumps.it  
Tel. +39 0426 34 63 04  
Fax. +39 0426 34 91 26

