

pompetravaini

(Rev. 2.0_10-2010)

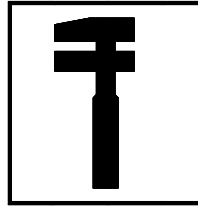

DISASSEMBLY AND ASSEMBLY INSTRUCTIONS FOR LIQUID RING COMPRESSORS

SA

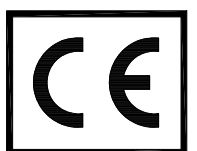
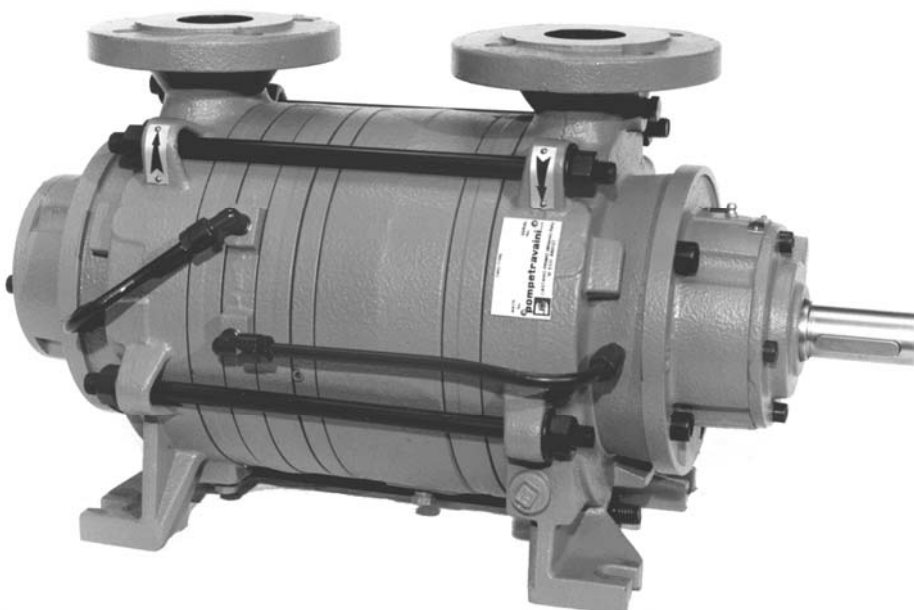

INTRODUCTION

These instructions are for the maintenance personnel for maintenance and repair of compressors series SA. Disassembly and assembly procedures should be carried out by qualified personnel. Prior to working on the compressors the maintenance person should be fully knowledgeable of the material outlined in this manual. Instructions relating to safety of operation, installation and maintenance will be found in the "OPERATING MANUAL FOR LIQUID RING VACUUM PUMPS AND COMPRESSORS" which is usually supplied with the compressor or it can be requested from your POMPETRAVAINI representative.

Proper attire is necessary prior to beginning any work on the compressors. Therefore, for your safety, always wear safety hat, eyeglasses, gloves, shoes etc. and be sure to have proper tools necessary for the work to be done.

Do not force or subject compressor or any of its components to sudden shocks or violent impact. Do not damage with markings or scratches the mechanical seal surface areas, the engagement surfaces and sealing areas. Do not damage gaskets, and O-Rings. Do not leave in the compressor foreign matter such as screws, nuts, bolts, washers, rags, etc.

When requesting spare parts or technical information for the pump, always quote the pump model number and serial number which is printed on the pump nameplate: therefore it is recommended not to remove the pump nameplate or, in case this action will be necessary, write the serial number on the pump (for example on the flange).

Should additional information be required, please do not hesitate to contact POMPETRAVAINI or the closest representative. Should there be any difficulties in repairing the pump, it is recommended to send the pump for repair to POMPETRAVAINI or the local authorised representative.

POMPETRAVAINI will not and cannot be responsible for work done on the compressor by the customer or non-authorised personnel.

NOTE: Compressor parts are identified by item numbers (VDMA). Item numbers can be found in the parts list under chapter 11 and cross-referenced with the sectional drawing under chapter 12.

All drawings given in these instructions are only schematics and not certified.

INDEX

- 1 - Preparation prior to compressor disassembly**
- 2 - Disassembly to replace bearings and/or mechanical seals**
- 3 - Mechanical seals assembly**
 - 3.1 - *Assembly of the stationary part in the bearing housing*
 - 3.2 - *Assembly of the rotating part on the shaft*
- 4 - Bearings assembly**
 - 4.1 - *Assembly of the bearing - non drive end*
 - 4.2 - *Assembly of the bearing - drive end*
- 5 - Bearings lubrication**
- 6 - Compressors total disassembly for cleaning purposes**
- 7 - Assembly of SA0E3U model compressor after cleaning**
 - 7.1 - *Assembly sequence of SA0E3U model compressor*
- 8 - Assembly of SA0G2D & SA0G2G model compressors after cleaning**
 - 8.1 - *Assembly sequence of SA0G2D & SA0G2G after cleaning*
- 9 - Compressors total disassembly for complete overhaul**
 - 9.1 - *Machining of SA0E3U model compressor*
 - 9.1.1 - *Preliminary assembly of SA0E3U model compressor*
 - 9.2 - *Machining of SA0G2D & SA0G2G model compressors*
 - 9.2.1 - *Preliminary assembly of SA0G2D & SA0G2G model compressors*
 - 9.3 - *Typical sketch for machining to restore planes*
- 10 - Spare parts**
- 11 - Compressors parts list**
- 12 - Compressors sectional drawings**



The liquids and the gases handled by the pumps and also their parts could be potentially dangerous for persons and environment: provide their eventual disposal in conformity with the laws into force and a proper environment management.



The present manual is not assigned for pumps subjected to the ATEX 94/9/CE directive. In case the pump is assigned in environments subjected to the application ATEX 99/92/CE directive or in case the pump is provided with a nameplate indicating the ATEX stamp, it is strictly forbidden proceed to start up the pumps but necessary to consult POMPETRAVAINI for clarifications.

For pumps subjected to the ATEX 94/9/CE directive it is available a dedicated integrative manual.

1 - PREPARATION PRIOR TO COMPRESSOR DISASSEMBLY

In the event compressor repair is necessary, it is important to be familiar with work to be carried out. See also the attached "Operating manual for liquid ring vacuum pumps and compressors".



FOLLOW THE SAFETY PRECAUTIONS LISTED IN CHAPTER 2 OF ABOVE MANUAL.

Prior to working on the compressor it is important to:

- procure and wear safety attire (hat, glasses, gloves, shoes, etc.)
- disconnect electrical power and, if required, disconnect electrical cable from motor terminal box
- close valves at compressor suction and discharge side
- allow compressor to cool down if it has been handling hot liquids
- follow safety precautions if hazardous fluids have been handled by the compressor
- drain compressor casing of any handled liquid through the draining connections and, if required, rinse the compressor with neutral liquid.

If it is necessary to remove compressor and motor from installation, proceed as follows:

- remove flange bolts from compressor suction and discharge connections
- remove the coupling guard
- remove the spacer coupling, if applicable
- if it is required to remove the motor, remove the anchor bolts from the motor feet or (in case of monoblock design) from the motor flange, then remove the motor
- remove the anchor bolts from the compressor feet
- remove the compressor from the baseplate.

2 - DISASSEMBLY TO REPLACE BEARINGS AND/OR MECHANICAL SEALS

The compressors are manufactured in such a manner as to make possible the replacement of the mechanical seals and of the bearings without disassembly the compressor completely, but only by acting on the bearing housings.

If it is possible, completely empty the compressor of the pumped liquid.

Disassembly is carried out by following the indications given on tab. 1 and 2, which show, on the line of the compressor concerned, the sequence and the numeric amount of the details to be disassembled.

In order to extract the bearing housings, use an adequate puller.

CAUTION: The greatest care is recommended when disassembly the mechanical seals in order to prevent damaging their most delicate parts.

Tab. 1 - DISASSEMBLY OF BEARING AND MECHANICAL SEAL - DRIVE END

COMPONENT VDMA N°	TUBING		CIRCLIP	SCREW	BEARING COVER		CIRCLIP	NUT	SCREW	BEARING HOUSING		BEARING	SHOULDER RING		GASKET	MECHANICAL SEAL
	701.2	701.4			932.3	914				365	360		932	923		
COMPRESSOR MODEL																
SA0E3U	1		1		1		1		4	1		1	1	1	1	1
SA0G2D SA0G2G		1		4		1		1	4		1	1	1	1	1	1

Tab. 2 - DISASSEMBLY OF BEARING AND MECHANICAL SEAL – NON DRIVE END

COMPONENT VDMA N°	TUBING		CIRCLIP	SCREW	BEARING COVER		NUT	SCREW	BEARING HOUSING	BEARING		SHOULDER RING	GASKET	MECHANICAL SEAL
	701.1	701.3	932.3	914	365.1	360.1	923	914.1	357.1	321	320	505	400.2	433.1
COMPRESSOR MODEL														
SA0E3U	1		1		1		1	4	1	1		1	1	1
SA0G2D		1		4		1	1	4	1		1	2	1	1
SA0G2G														

Check the conditions of disassembled components and procure all possible original spare parts (such as bearings, mechanical seals, gaskets, seal rings, etc.).

Any spare parts that are not original, shall be compatible with the sizes and performances of the original ones.

Carefully clean all details that are still in good conditions.

In order to disassemble the mechanical seal and the bearing, see instructions on chapters 3 and 4.

3 – MECHANICAL SEALS ASSEMBLY

NOTE: The mechanical seals mounted on the compressors are unified according to DIN 24960/K standard having short working length "L1".

On the disassembled details, please check the dimensions for the assembly of the mechanical seal VDMA 433.1 and/or 433.2: the dimensions "G" and "F" on the bearing housing VDMA 357 and/or 357.1 (or on the seal bush VDMA 542, when provided), the dimension "D" on the shaft VDMA 210, the dimension "L" on the casing VDMA 106 and/or 107 and the bush VDMA 485 (see drawing of control dimensions on fig. 1 and tab. 3).

Restore the correct working dimensions of the mechanical seal taking into account that, for any possible corrections on length "L1", it is possible to operate on bush VDMA 485.

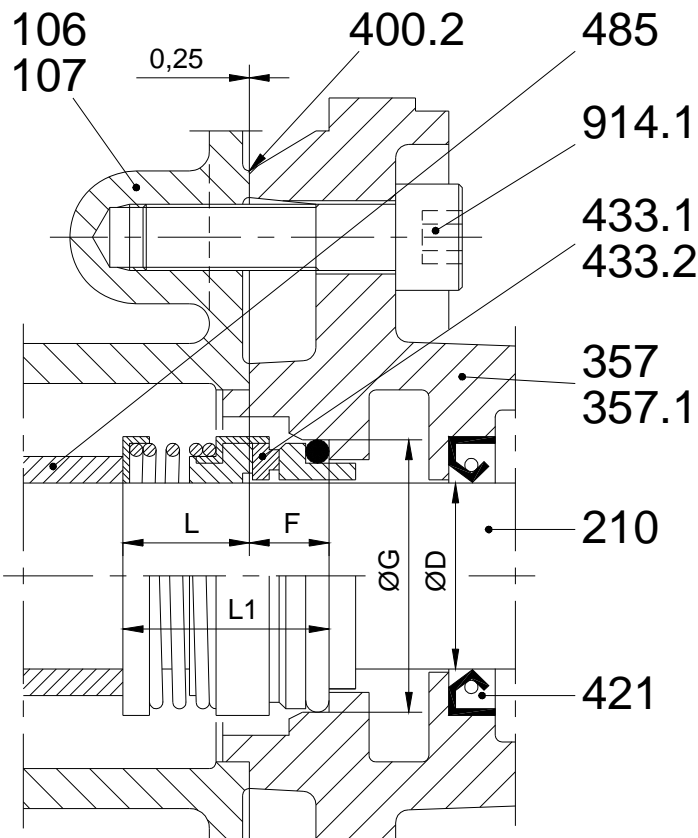

Fig. 1
Typical drawing of mechanical seal with dimensions valid for both sides

Tab. 3 - MECHANICAL SEALS DIMENSIONS

COMPRESSOR MODEL	Ø D h6	F	Ø G H8	L	L1 ±0,5
SA0E3U	28	18	43	24,5	42,5
SA0G2D SA0G2G	43	16	61	29	45

3.1 - ASSEMBLY OF THE STATIONARY PART IN THE BEARING HOUSING

The housing of the seal ring which is the stationary part of the mechanical seal in the bearing housing and the fitting shall be perfectly clean and shall not show any marks of machining.

Slightly wet (using water, liquid soap, etc., but avoiding the use of oils) the housing and the O-Ring of the stationary part of the mechanical seal. Push the stationary part of the mechanical seal into the housing using a buffer protected with plastic or similar material, which perfectly acts in the axis to the piece; to this purpose either a crank press or the spindle of a drill can be used (see fig. 2).

MECHANICAL SEAL - STATIONARY PART - WITH O-RING

MECHANICAL SEAL SEATING WITH SMOOTH AND CHAMFERED EDGES

3.2 - ASSEMBLY OF THE ROTATING PART ON THE SHAFT

The shaft VDMA 210 shall be smooth, clean, without sharp edges and slightly wet (using water, liquid soap etc: but avoiding the use of oils).

Even if the shaft has been ground, it shall be rectified again with very fine, "00" type abrasive paper or emery cloth.

Insert the bush VDMA 485 on the shaft, slide on the whole rotating part of the mechanical seal on the conic bush "A" or any similar tool (see fig. 3) with smooth and slightly wet surface (using water or liquid soap etc. but avoiding the use of oils).

Push the rotating part of the seal using the inserting device "B" or any other similar tool until it stops, taking the necessary care.

NOTE: The mechanical seals with one only sense of rotation have to be assembled on compressor side according to shaft sense of rotation.

Fig. 3

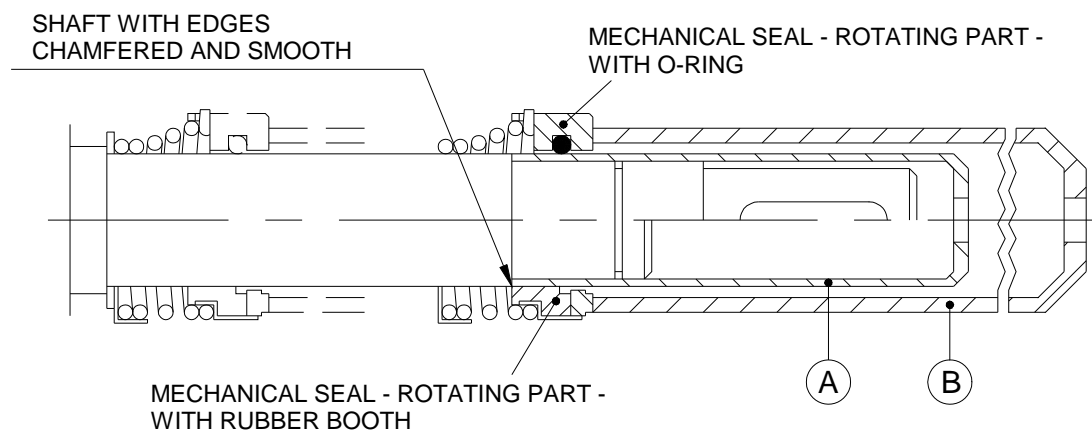
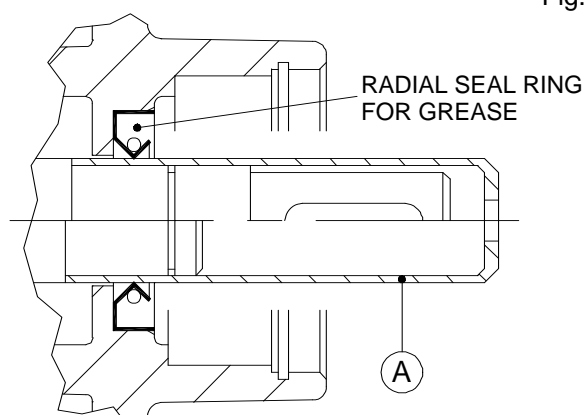

Fig. 4

Assemble the bearing housing VDMA 357 and/or 357.1 complete with seal ring VDMA 421 (see fig. 4), with seal bush VDMA 542 (when provided), with stationary part of the mechanical seal VDMA 433.1 or 433.2, with gasket VDMA 400.2.

CAUTION: The inspection slot in the bearing housing shall be directed downwards.

Then block the screws VDMA 914.1 in the casing VDMA 106 and/or VDMA 107.



In order to be able to start the assembly of the bearings you must be at the point of having already mounted the mechanical seal and the bearing housing as described on chapter 3.

4.1 - ASSEMBLY OF THE BEARING - NON DRIVE END

After having carried out the operations indicated above, mount the shoulder rings VDMA 505 (re-use the old ones, provided that they are in good conditions or place new ones paying attention that they are equal to the dimensions indicated on fig. 5 or 6 under the item of shoulder rings "A"), install the bearing VDMA 320 or 321 on the shaft with a proper tool and tighten the nut VDMA 923.

For the SA0E3U model compressor, insert the wave spring VDMA 935, the bearing cover VDMA 365.1 and the circlip VDMA 932.3.

For the SA0G2D and SA0G2G model compressors, mount the bearing cover VDMA 360.1 and tighten the screws VDMA 914.

Fig. 5 - Locking of bearings for SA0E3U model compressor

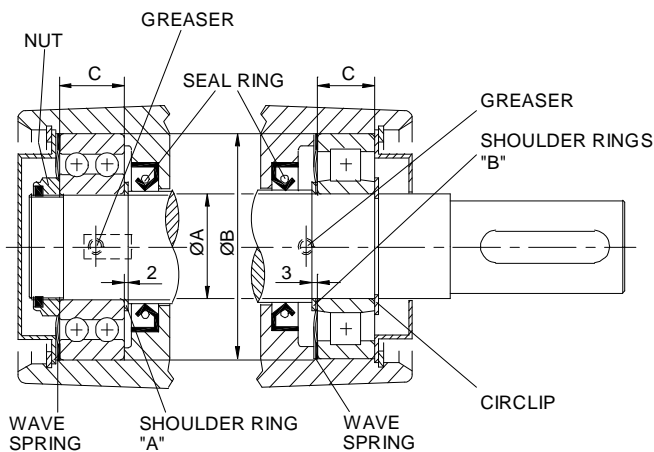
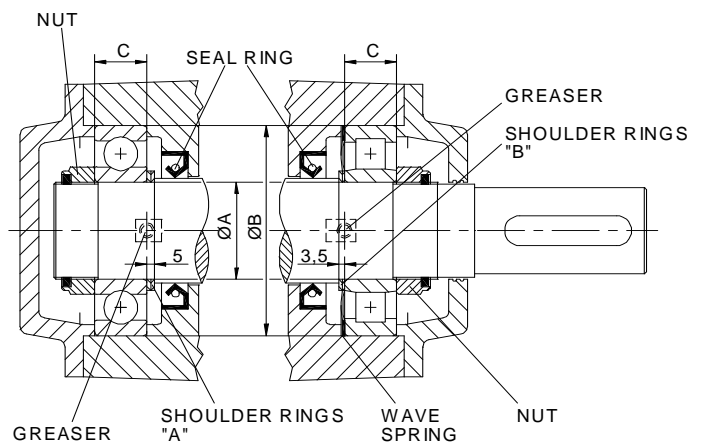

Fig. 6 - Locking of bearings for SA0G2D and SA0G2G model compressors



Tab. 4 - BEARING DIMENSIONS

COMPRESSOR MODEL	BEARINGS DIMENSIONS					QUANTITY OF GREASE FOR BEARING in g.
	Ø A	Ø B	C	NON DRIVE END TYPE	DRIVE END TYPE	
SA0E3U	25	62	17	-----	NU 305	15
			24	4305	-----	
SA0G2D SA0G2G	40	90	23	-----	NU 308	20
				6308	-----	

4.2 - ASSEMBLY OF THE BEARING - DRIVE END

Make sure that the dimensions assessed between the shaft shoulder and the shoulder of the bearing housing are those indicated on fig. 7 or 8 and, therefore, the dimensions of the shoulder rings are those indicated on fig. 5 or 6 under the item "B" shoulder rings.

If the dimensions are higher, adjust them by means of using shoulder rings of various sizes to get proper height.

Instead, if any machining previously carried out on the internal details of the compressor have caused the dimensions of the "B" shoulder rings to be lower than those indicated on fig. 7 or 8, restore them by carrying out proper machining on the shaft shoulder (this condition should have already been evaluated and solved, if a preliminary assembly has been carried out as indicated on chapter 9 and if the sum total of the material removed by machining from the spacers and from the elements of the compressor has been taken into account).

In order to complete the assembly of the bearing housing drive side, insert the wave spring VDMA 935 and push the bearing VDMA 323 using a proper tool.

For the SA0E3U model compressor, insert the circlip VDMA 932, the bearing cover VDMA 365 and the circlip VDMA 932.3.

For SA0G2D and SA0G2G model compressors, tighten the lock nut VDMA 923, assembly the bearing VDMA 360 and tighten the screws VDMA 914.

Fig. 7 - Dimension of bearing shoulders for SA0E3U model compressor

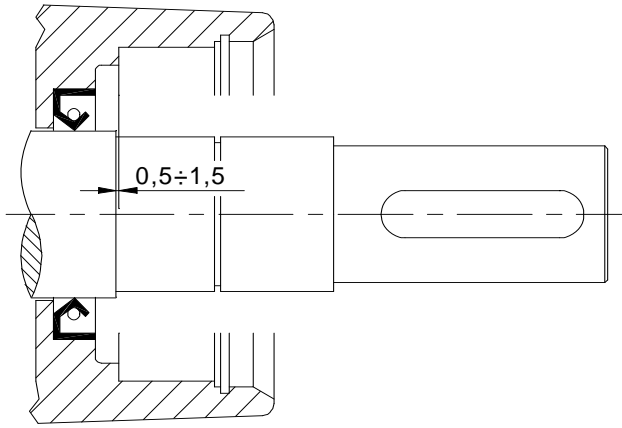
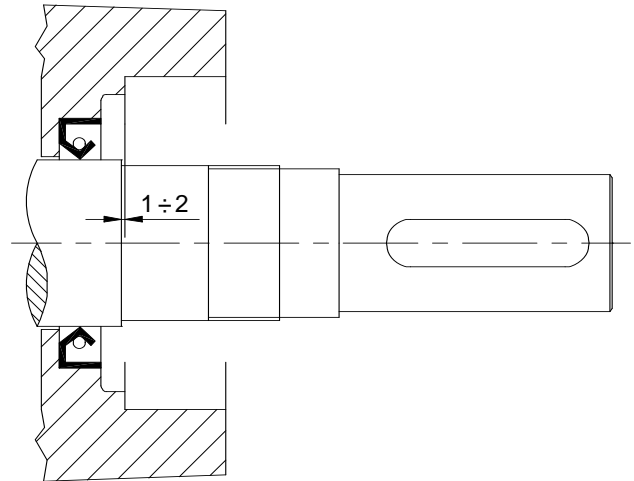

Fig. 8 - Dimension of bearing shoulders for SA0G2D and SA0G2G model compressors



5 - BEARINGS LUBRICATION

For the lubrication of the bearings, keep to the requirements of bearings suppliers.

For the normally running compressors, bearings greasing shall occur after maximum 1000 working hours.

In any case, always keep under control the running of bearings, checking their temperature and noise level.

For the maintenance of bearings that have been disassembled and can still be used, it is necessary to remove the old grease and dirt in the interstices (if possible, also from the seal rings), then fill with new lubricating grease.

The lubricant type used by us is type "EP 3", grease with temperature limits of use of -30°C to +140°C.

Equivalent greases or greases with greater performances can be used.

Before running, for safety reasons, it is better to carry out greasing by using a special grease gun.

When required, the maximum amount of lubricant is given on tab. 4.

When replacing the grease, it may be necessary to carry out the renewal of lubrication.

This depends mainly on the temperature and on the stress the bearing must stand.

We remind you that the amount of lubricant required for a correct operation is of about 50% of the total capacity of the bearing chamber (see tab. 4).

6 - COMPRESSORS TOTAL DISASSEMBLY FOR CLEANING PURPOSES

NOTE: If the person assigned to this work is not familiar with compressor design, it is a good practice to mark the housings positions and note (rotation and assembly sequence) of the various components among them; however, in the external upper part of all housings there is a reference mark applied during casting to make possible the correct position alignment of housings.

A wrong positioning can cause a partial or even total lack of performances by the compressor.

Before starting the disassembly, empty the compressor of all possible liquid, place it in vertical position on a bell similar to the one shown on fig. 12 and 13 and start to disassemble the bearing housing drive end (see chapter 2, tab. 1).

The following table shows the sequence and the numeric amount of the details to be disassembled on the line of the indicated compressor model.

Use proper tools and procedure in disassembly in order not to damage the compressor components.

Tab. 5 - COMPRESSOR TOTAL DISASSEMBLY

COMPONENT VDMA N°	TIE-BOLT	SUCTION CASING	PORT PLATE		GRUB SCREW	NUT	IMPELLER HOUSING	IMPELLER	PORT PLATE	PORT PLATE	IMPELLER HOUSING	IMPELLER	PORT PLATE	IMPELLER HOUSING	IMPELLER	PORT PLATE	DISCHARGE CASING
COMPRESSOR MODEL	905	106	109	137.1	904.1	922	110	230	137.2	137.3	110.1	230.1	137.2	110.1	230.1	137.4	107
SA0E3U	4	1	1			2	1	1	1		1	1	1	1	1	1	1
SA0G2D SA0G2G	5	1		1	1	1	1	1	1	1	1	1				1	1

Then continue disassembly the bearing housing non-drive end (see chapter 2, tab. 2).
 Inspect all components forming the compressor and make sure their in good condition.
 If they are in good re-usable condition, start cleaning the compressor and wash the port plates where the sealing gasket liquid has been applied, using proper thinner.

7 - ASSEMBLY OF SA0E3U MODEL COMPRESSOR AFTER CLEANING

Before actually starting to assemble, carefully read these instructions to prepare for the operations to be accomplished and arrange all compressor components and the necessary tools within reach.

Tighten the shaft VDMA 210 in horizontal position in a vice using the inserted key VDMA 940.1, slide on the impellers VDMA 230 and 230.1 on the shaft and make sure that they fit properly, otherwise arrange for it.

CAUTION: Before mounting the impellers on the shaft, pay attention that the direction of blades (angle) corresponds to the drawing of fig. 10.

Remove the impellers and start to assemble from the mechanical seal (see chapter 3), continue the operations accomplishing the assembly of the non drive end bearing (see chapter 4).

Remove the shaft from the vice with the complete bearing housing VDMA 357.1 mounted on it, place the gasket VDMA 400.2, the discharge casing VDMA 107, then lock the screws VDMA 914.1.

Place assembly in a vertical position with the bearing housing resting on a bell similar to the one shown on fig. 12.

Prepare the sealing gasket liquid for port plates to be used as gasket. The liquid commonly used and available in tubes from our spare parts is "LOCTITE 510 Superrapido" in 50 ml tubes, sufficient for the assembly of one compressor.

NOTE: For general practice, it is recommended to carry out a **preliminary assembly** of the compressor without using any sealing gasket liquid.

Mount the shoulder ring VDMA 504 and the port plate VDMA 137.4. The alignment pin VDMA 562 will align the impeller housing VDMA 110.1.

The drawing of fig. 9 shows the notches or assembly references on the external part of all housings to be used for alignment purposes.

Slide on the impeller VDMA 230.1 and the impeller housing VDMA 110.1 which will complete the third with the addition of the packing ring VDMA 462.

Then complete the first stage mounting the port plate VDMA 137.2, the impeller VDMA 230 and the impeller housing VDMA 110.

Lock all components on the shaft by means of the impeller nuts VDMA 922.

The housing of the first stage VDMA 109 shall be mounted with proper alignment of the other housings and then mount the suction casing VDMA 106.

Insert the 4 tie-bolts VDMA 905 and slightly tighten them, turn the compressor so that the 2 casings are aligned with their feet resting on a flat horizontal plane unloosening the tie-bolts (must be on flat level surface).

Then tighten the tie-bolts using a proper torque wrench (see tab. 6 for the force to apply).

Make sure that the compressor shaft turns freely by hand. If it is not so, disassemble the compressor and check all components until the cause has been found.

To re-due this, arrange for the restoration of the clearances required for this model of compressor (see chapter 9), then mount the compressor again as indicated above.

Assemble the mechanical seal (see chapter 3) and the drive end bearing (see chapter 4).

Finish by mounting the circulation tubing VDMA 701.1 and 701.2 with the corresponding fittings VDMA 731.3 and 731.6.

In order to check the correct assembly and the perfect hydraulic seal of the compressor, carry out a hydrostatic test under a pressure of 10 bar (140 PSIG maximum).

Tab. 6 - TIE-BOLTS (VDMA 905)
TORQUE RATING

COMPRESSOR MODEL	TORQUE RATING	
	Kgm	Nm
SA0E3U	6,5	63,8
SA0G2D SA0G2G	6	58,9

7.1 - ASSEMBLY SEQUENCE OF SA0E3U MODEL COMPRESSOR

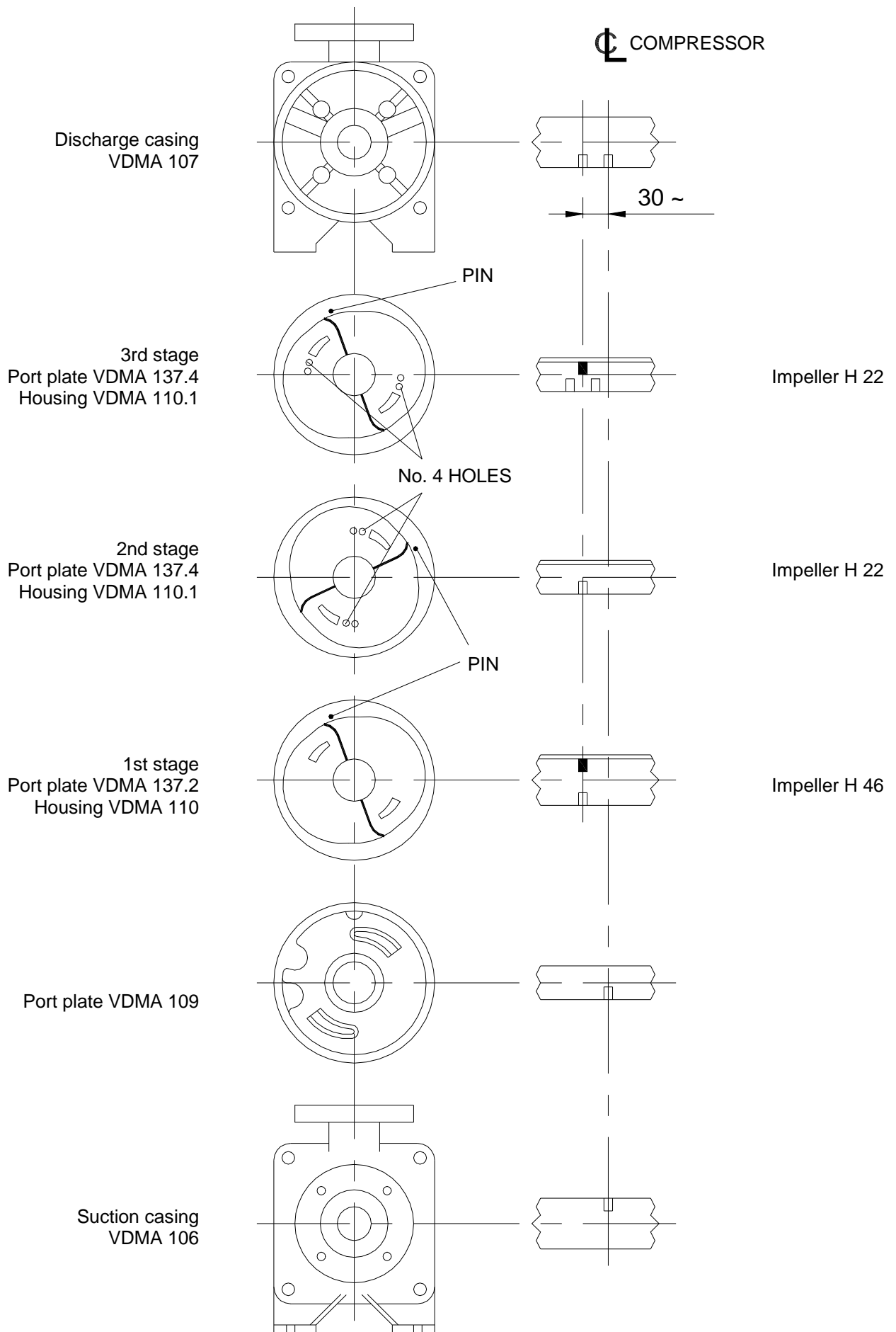

Fig. 9

Before actually starting the assembly, carefully read these instructions to prepare for the operations to be accomplished and arrange all compressor components and the necessary tools within reach.

Tighten the shaft VDMA 210 in horizontal position in a vice using the inserted key VDMA 940.1, slide on the impellers VDMA 230 and 230.1 on the shaft and make sure that they fit properly, otherwise arrange for it.

CAUTION: Before mounting the impellers on the shaft, pay attention that the direction of blades (angle) corresponds to the drawing of fig. 10.

Remove the impellers and start to assemble starting from the mechanical seal (see chapter 3), continue the operations accomplishing the assembly of the non drive end bearing (see chapter 4)

Remove the shaft from the vice with the complete bearing housing VDMA 357.1 mounted on it, place the gasket VDMA 400.2, the discharge casing VDMA 107, then lock the screws VDMA 914.1.

Place assembly in a vertical position with the bearing housing resting on a bell similar to the one shown on fig. 13.

Prepare the sealing gasket liquid for port plates to be used as gasket. The liquid commonly used and available in tubes from our spare parts is "LOCTITE 510 Superrapido" in 50 ml tubes sufficient for the assembly of one compressor.

NOTE: For general practice, it is recommended to carry out a **preliminary assembly** of the compressor without using any sealing gasket liquid.

Mount the port plate VDMA 137.4 with the external reference mark in line with that of the casing (the drawing of fig. 11 shows the notches or assembly references on the external part of all housings to be used for alignment purposes), and the shoulder ring VDMA 504. Slide on the impeller VDMA 230.1 and the impeller housing VDMA 110.1, then the port plate VDMA 137.3 and the corresponding radial seal ring VDMA 462, the port plate VDMA 137.2, the impeller VDMA 230, the impeller housing VDMA 110. Lock all components on the shaft by means of the impeller nut VDMA 922 (remember to tighten the 2 set screws VDMA 904.1), mount the port plate VDMA 137.1 and the suction casing VDMA 106.

Insert the 5 tie-bolts VDMA 905 and slightly tighten them, turn the compressor in such a way as to align the 2 casings with their feet resting on a flat horizontal plane unloosening the tie-bolts. (must be on flat level surface).

Then tighten the tie-bolts by means of a proper torque wrench (see tab. 6 for the force to apply).

Make sure that the compressor shaft turns freely by hand. If it is not so, disassemble the compressor and check all components until the cause has been found.

To re-do this, arrange for the restoration of the clearances required for these compressors model (see chapter 9), then mount the compressor again as indicated above.

Assemble the mechanical seal (see chapter 3) and the drive end bearing (see chapter 4).

Finish by mounting the circulation tubing VDMA 701.3 and 701.4 with the corresponding fittings VDMA 731.3.

In order to check the correct assembly and the perfect hydraulic seal of the compressor, carry out a hydrostatic test under a pressure of 10 bar (140 PSIG maximum).

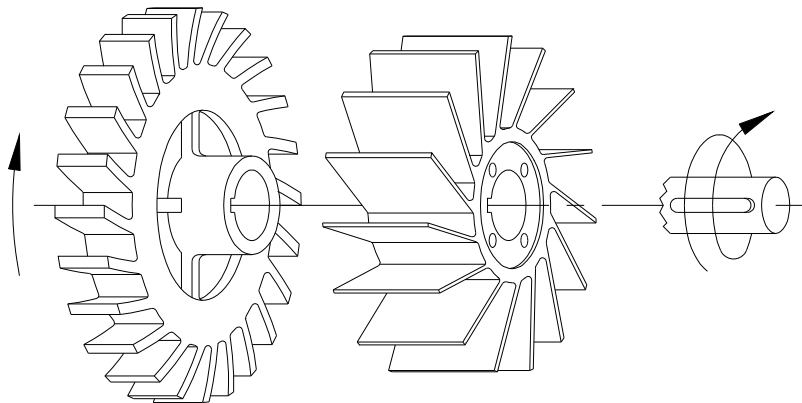

Fig. 10

8.1 - ASSEMBLY SEQUENCE OF SA0G2D & SA0G2G MODEL COMPRESSORS

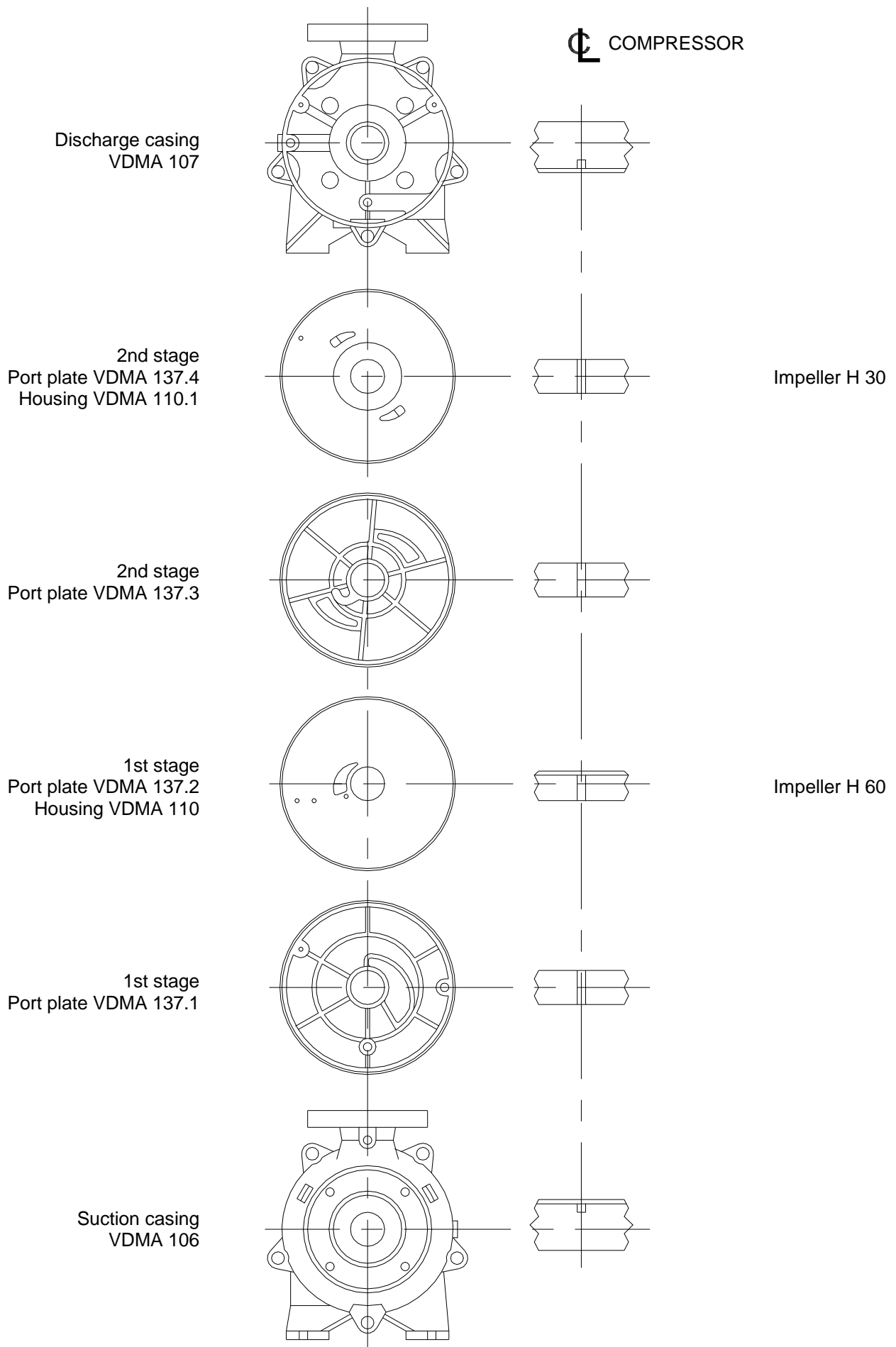

Fig. 11

For total overhaul of the compressor we refer to a compressor with worn impellers or port plates, so that it does not give the required performances, or with wear on the shaft, so that it is not possible to obtain the proper seal of liquid on the shaft. To disassemble the compressor proceed as already described on chapter 2. The machining described below is required for this compressor model if it is possible to reuse the old components again.

When original spare parts are used, check that they are compatible with the dimensions obtained by machining the reused components. For the recommended spare parts see chapter 11.

9.1 - MACHINING OF SA0E3U MODEL COMPRESSOR

After having carried out all the machining operations for port plates restoration, "H" dimension of impeller housings shall be higher than 0,25 mm for cast iron compressors and 0,5 mm for stainless steel compressors with respect to that of the impellers "H1".

The dimension "H2" of the impeller hubs shall be higher than 0,25 mm for cast iron compressors and 0,5 mm for stainless steel compressors with respect to the dimension "H3" of the port plates VDMA 137.2 and 137.4.

Therefore, the total final clearance between the impeller and its housings will be, taking into account also the thickness of the sealing gasket liquid (about 0,05 mm) which will be placed between impeller housings and the port plates, of min. 0,27 mm and max. 0,30 mm for cast iron compressors, of min. 0,52 mm and max. 0,55 mm for stainless steel compressors (see sketch on fig. 14).

After having completed the operations, before the final assembly of the compressor with sealing gasket liquid, carry out a **preliminary assembly** to check the correct position of the impellers between its own housings.

9.1.1 - PRELIMINARY ASSEMBLY OF SA0E3U MODEL COMPRESSOR

Mount the mechanical seal (see chapter 3) and the non drive end bearing (see chapter 4), then the gasket VDMA 400.2, the discharge casing VDMA 107, the port plate VDMA 137.4 and the shoulder ring VDMA 504.

This ring shall protrude from the port plate by 0,10 mm, namely about half the clearance existing between the impeller and the housing (see fig. 12). Continue the complete assembly up to the suction casing VDMA 106, proceeding as indicated on chapter 7. Slightly tighten the tie-bolts VDMA 905, then place the compressor resting with its own feet on a flat horizontal plane unloosening the tie-bolts, align everything and tighten the tie-bolts using a torque wrench (see tab. 6 for the force to apply).

At this point, the compressor must turn by hand. If everything is proper, start disassembly the impeller assembly, the port plates and impeller housings up to the discharge casing VDMA 107 and then start again the final assembly with sealing gasket liquid (see chapter 7).

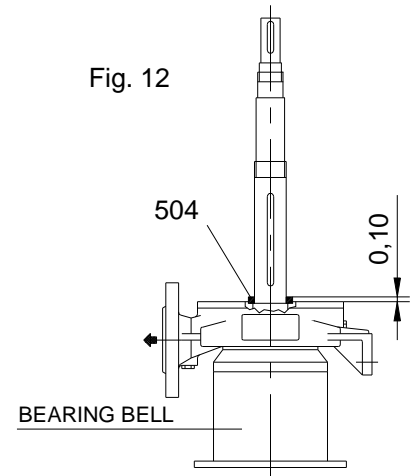

9.2 - MACHINING OF SA0G2D & SA0G2G MODEL COMPRESSORS

After having carried out the machining operations for port plates restoration, the "H" dimension of impeller housings shall be higher by 0,35 mm for cast iron compressors and 0,55 mm for stainless steel compressors with respect to that of the impellers "H1".

The dimension "H2" of the impeller hub shall be higher than 0,35 mm for cast iron compressors and 0,55 mm for stainless steel compressors with respect to the dimension "H3" of the port plates VDMA 137.2 and VDMA 137.3.

Therefore, the total final clearance between the impeller and its housing will be, taking into account also the thickness of the liquid gasket seal (about 0,05 mm) which will be placed between the impeller housings and the port plates, of min. 0,37 mm and max. 0,40 mm for cast iron compressors, of min. 0,52 mm and max. 0,55 mm for stainless steel compressors (see sketch on fig. 15).

After having completed the operations, before the final assembly of the compressor with sealing gasket liquid, carry out a **preliminary assembly** to check the correct position of the impellers between its own housings.

9.2.1 - PRELIMINARY ASSEMBLY OF SA0G2D & SA0G2G MODEL COMPRESSORS

Mount the mechanical seal (see chapter 3) and the non drive end bearing (see chapter 4), then the gasket VDMA 400.2, the discharge casing VDMA 107, the element VDMA 137.4 and the shoulder ring VDMA 504. This ring shall protrude from the port plate by 0,15 mm, namely about half the clearance existing between the impeller and the housing (see fig. 13).

Continue the complete assembly up to the suction casing VDMA 106, proceeding as indicated on chapter 8. Slightly tighten the tie-bolts VDMA 905, then place the compressor resting with its own feet on a flat horizontal plane unloosening the tie-bolts, align everything and tighten the tie-bolts using a torque wrench (see tab. 6 for the force to apply).

At this point the compressor must turn by hand, if everything is proper, start disassembly the impeller assembly, the port plates and impeller housings up to the discharge casing VDMA 107, and then start again the final assembly with sealing gasket liquid (see chapter 8).

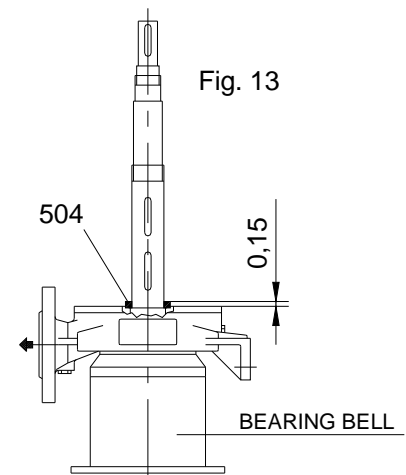

9.3 - TYPICAL SKETCH FOR MACHINING TO RESTORE PLANES

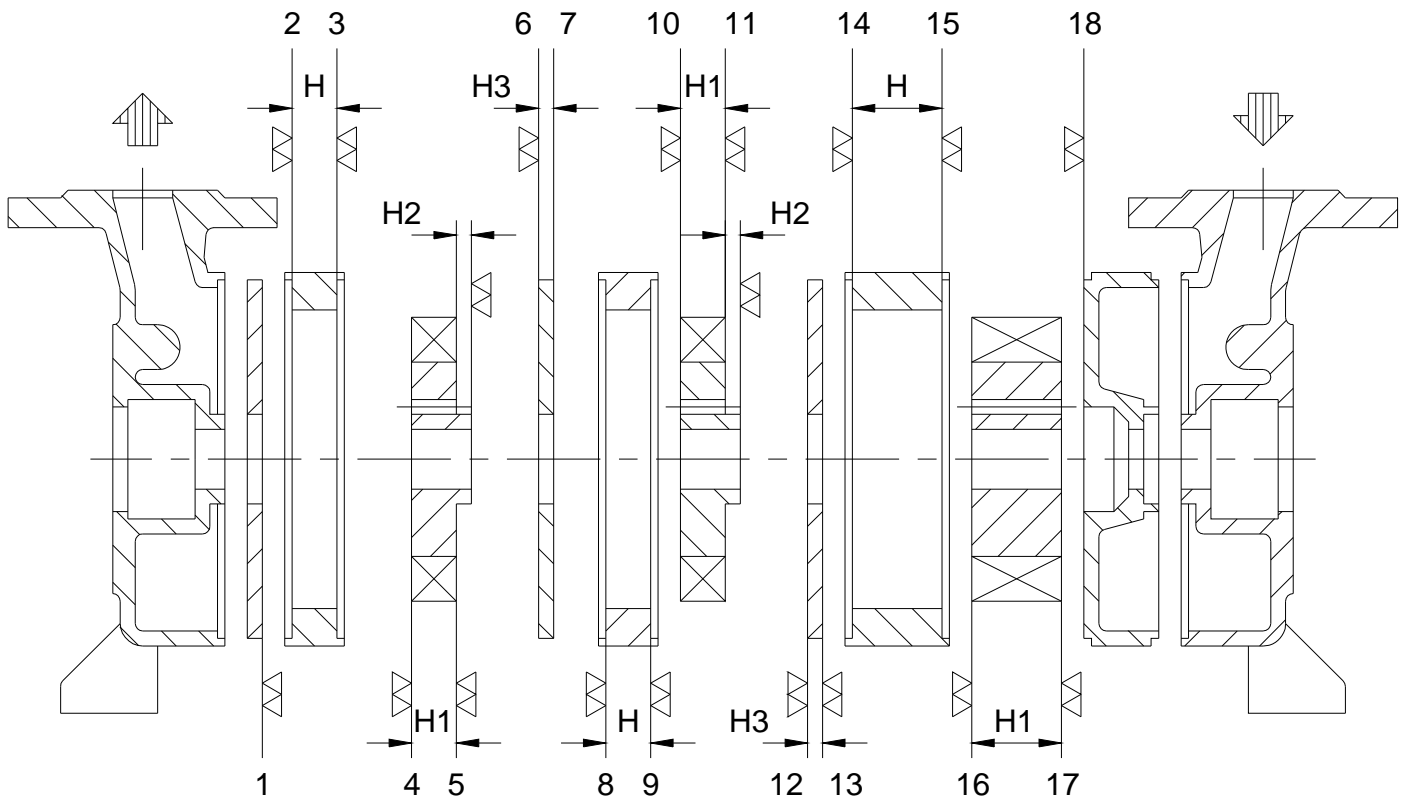

Fig. 14 - Compressor model SA0E3U

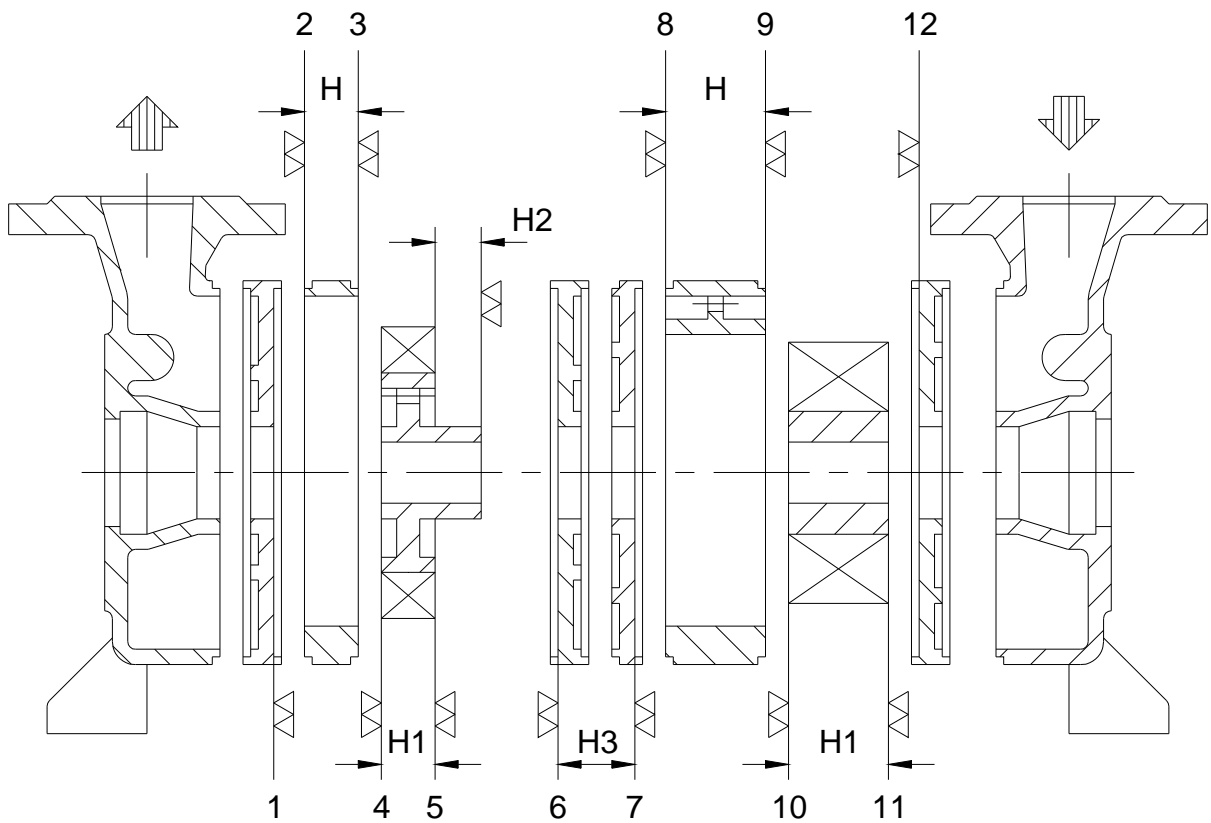

Fig. 15 - Compressors model SA0G2D & SA0G2G

10 - SPARE PARTS

When ordering the compressor it is good practice to also order the recommended spare parts, especially when there are no stand-by units in the installation. This will minimise unnecessary down times in the event of compressor failure.

Therefore, depending upon the compressor model and the number of compressors installed, the quantity of spare parts to be kept on hand should be determined.

Following are the minimum recommended spare parts:

- 1 Set of impellers
- 1 Set of port plates
- 1 Complete shaft
- 1 Set of bearings
- 1 Set of mechanical seals
- 1 Set of gaskets
- 1 Sealing gasket liquid for planes
- 1 Set of shoulder rings for bearings

When ordering spare parts always provide the information printed on the compressor nameplate: compressor model, serial number and year of manufacture.

Provide also the part item number, description and quantity required which is found on sectional drawings (chapter 12) and parts list (chapter 11).

We recommend the use of original spares: in case this is not respected, you lose the right of guarantee and POMPETRAVAINI declines any responsibility.

11 - COMPRESSORS PARTS LIST

VDMA No.	DESCRIPTION
106	Suction casing
107	Discharge casing
109	Port plate
110	Impeller housing
110.1	Impeller housing
137.1	Port plate
137.2	Port plate
137.3	Port plate
137.4	Port plate
210	Shaft
230	Impeller
230.1	Impeller
320	Single row ball bearing
321	Double row ball bearing
323	Roller bearing
357	Bearing housing
357.1	Bearing housing
360	Bearing cover
360.1	Bearing cover
365	Bearing cover
365.1	Bearing cover
400.2	Gasket
421	Seal ring
433.1	Mechanical seal
433.2	Mechanical seal
462	Packing ring
485	Mechanical seal bush

VDMA No.	DESCRIPTION
504	Shoulder ring
505	Shoulder ring
505.1	Shoulder ring
542	Seal bush (A3 construction only)
562	Pin
636	Greaser
701.1	Tubing
701.2	Tubing
701.3	Tubing
701.4	Tubing
731.3	Fitting
731.6	Fitting
734	Fitting
735	Fitting
903	Plug
904	Grub screw
904.1	Grub screw
905	Tie-bolt
914	Screw
914.1	Screw
922	Nut
923	Nut
932	Circlip
932.3	Circlip
935	Wave spring
940	Key
940.1	Key

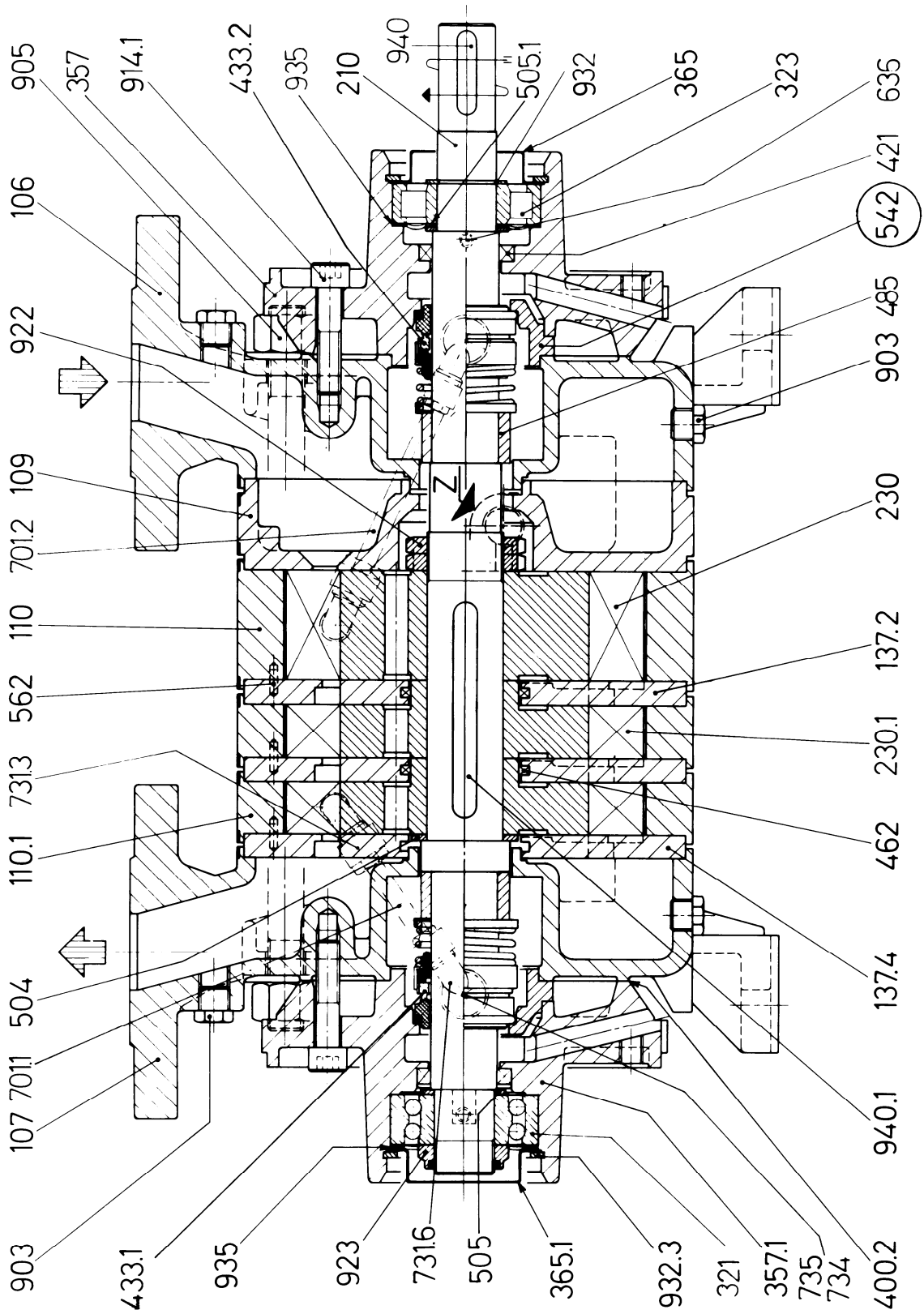

Compressor model SA0E3U

○ Applicable only for Stainless Steel

