

pompetravaini

(Rev. 2.1_04-2011)

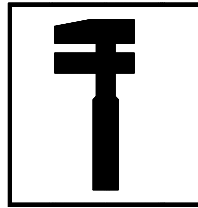

**DISASSEMBLY AND
ASSEMBLY INSTRUCTIONS
FOR
LIQUID RING VACUUM PUMPS
SINGLE STAGE
WITH MECHANICAL SEAL
TRMX 257 – TRVX 257**

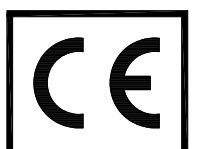

INTRODUCTION

These instructions are for the maintenance staff in case of repair for the following pumps:

TRMX 257 & TRVX 257

These instructions are supplied together with the manual of "INSTALLATION, OPERATION AND MAINTENANCE INSTRUCTIONS FOR LIQUID RING VACUUM PUMPS".

They provide a reference for safe operation, installation, maintenance and repairing of the pumps.

Prior to working on the pump it is recommended to follow the instructions of safety listed in chapters 2 and 15 of the above manual, as well is absolutely important to:

- wear safety clothing, hard hat, safety shoes, safety eye glasses
- disconnect the electrical power
- close suction valves and service liquid valves
- remove pump from installation without damaging other system components
- assume all safety measures if pump has been handling dangerous fluids
- drain pump casings through the draining connections and flush the pump with clean liquid, if required.

When requesting spare parts or technical information for the pump, always quote the pump model number and serial number which is printed on the pump nameplate: therefore it is recommended not to remove the pump nameplate or, in case this action will be necessary, write the serial number on the pump (for example on the flange).

Should additional information be required, please do not hesitate to contact POMPETRAVAINI or the closest representative. Should there be any difficulties in repairing the pump, it is recommended to send the pump for repair to POMPETRAVAINI or the local authorised representative.

Any pump repairs and/or system work carried out by others will not be guaranteed by POMPETRAVAINI.

NOTE: VDMA numbers identify all pump components.

Refer to parts list in chapter 4 and to the section drawings in chapter 5.

All drawings are schematic only and are not certified for construction.

For further information please consult POMPETRAVAINI or its closest representative.

Torque values for various bolt sizes and tie-bolts are listed on fig. 4.

INDEX

- 1 - Pump disassembly**
 - 1.1 - *Disassembly of pump type TRMX 257*
 - 1.2 - *Disassembly of pump type TRVX 257*
- 2 - Pump assembly**
 - 2.1 - *Common assembly of pumps type TRMX 257 and TRVX 257*
 - 2.2 - *Bearing frame and lantern assembly of pump type TRVX 257*
 - 2.3 - *E-motor assembly of pump type TRVX 257*
- 3 - Recommended spare parts**
- 4 - Parts list**
- 5 - Typical sectional drawings**



The liquids and the gases handled by the pumps and also their parts could be potentially dangerous for persons and environment: provide their eventual disposal in conformity with the laws into force and a proper environment management.



The present manual is not assigned for pumps subjected to the ATEX 94/9/CE directive. In case the pump is assigned in environments subjected to the application ATEX 99/92/CE directive or in case the pump is provided with a nameplate indicating the ATEX stamp, it is strictly forbidden proceed to start up the pumps but necessary to consult POMPETRAVAINI for clarifications.

For pumps subjected to the ATEX 94/9/CE directive it is available a dedicated integrative manual.

In preparing this manual, every possible effort has been made to help the customer and operator with the proper installation and operation of the pump and/or system. Should you find errors, misunderstandings or discrepancies please do not hesitate to bring them to our attention.

1.1 – DISASSEMBLY OF PUMP TYPE "TRMX 257"

After removing the pump/motor assembly from the installation, proceed with the disassembly.

Remove the screws T.C.E.I. VDMA 914 that hold the suction/discharge casing VDMA 101 which can be successively uncoupled from the rest of the pump.

Check that the components of the special valve VDMA 180.5 and Teflon flapper VDMA 400.9 are in good working conditions. Remove the suction/discharge plate VDMA 137.

Verify that the internals of suction/discharge casing VDMA 101 are free of defects (wear, corrosion, cracks, etc.).

Remove the locking nut VDMA 920, remove the safety washer VDMA 554.L and remove the impeller VDMA 230 from the shaft and verify that the impeller is also free from defects and wear.

Remove the shaft key VDMA 940.1 and then remove the impeller cover VDMA 235 from the electric motor VDMA 801 by removing the screws T.E.F. VDMA 906 (check if there is any adjustment shim between the impeller cover VDMA 235 and the electric motor VDMA 801).

Now the rotating part of the mechanical seal VDMA 433.2 can slide out of the shaft and the stationary part of the mechanical seal can be gently pushed out of the the impeller cover VDMA 235.

Proceed with the inspection of all components, replace bad and/or worn parts with POMPETRAVAINI's original parts.

It is good practice to replace, as a minimum, all wear parts such as mechanical seal, gaskets, etc.

1.2 – DISASSEMBLY OF PUMP TYPE "TRVX 257"

After removing the pump/motor assembly from the installation remove, if required, the electric motor from the pump.

In this case, remove the screws T.E.F. and remove the electric motor.

Remove the screws T.C.E.I. VDMA 914 that hold the suction/discharge casing VDMA 101 which can be successively uncoupled from the rest of the pump.

Check that the components of the special valve VDMA 180.5 and Teflon flapper VDMA 400.9 are in good working conditions. Remove the suction/discharge plate VDMA 137.

Verify that the internals of suction/discharge casing VDMA 101 are free of defects (wear, corrosion, cracks, etc.).

Remove the locking nut VDMA 920, remove the safety washer VDMA 554.L and remove the impeller VDMA 230 from the shaft and verify that the impeller is also free from defects and wear.

Remove the shaft key VDMA 940.1 and then remove the impeller cover VDMA 235 from the bearing frame VDMA 330 by removing the screws T.E.F. VDMA 906 (check if there is any shoulder ring between the impeller cover VDMA 235 the bearing frame VDMA 330).

To disassemble the lantern VDMA 341, loosen the screws T.E.F., and pool it back, therefore, after having loosen the grub screw, remove the half coupling VDMA 861.1 from the drive shaft VDMA 210 by means of a suitable extractor. Remove the driving key VDMA 940 located on shaft drive end side. Remove the support foot VDMA 183 and its fixing screw VDMA 902.1.

To disassemble the bearing frame VDMA 330, loosen the screws T.C.E.I. VDMA 914.2, remove the bearing cover VDMA 360.1 with the respective V.RING seal VDMA 411, remove the pump side circlip VDMA 932 and the motor side circlip VDMA 932.3 with the respective elastic ring VDMA 935.

Gently push the shaft VDMA 210 towards the motor side and slide it out from the bearing frame VDMA.

Remove the pump side bearing from the bearing frame VDMA 330 and remove the motor side bearing from the shaft VDMA 210.

Proceed with the inspection of all components, replace bad and/or worn parts with POMPETRAVAINI's original parts.

It is good practice to replace, as a minimum, all wear parts such as mechanical seal, gaskets, etc.

2.1 – COMMON ASSEMBLY OF PUMPS SERIES "TRMX 257 – TRVX 257"

(See fig. 1 for mechanical seal dimensions, see fig. 4 for torque values of bolts and nuts, where not specifically indicated).

- For TRMX 257 only: place the electric motor VDMA 801 on its fan cover and slip the thrower VDMA 507 on the motor shaft. Keep the motor feet facing the pump assembler.
- For TRVX 257 only: assemble the support VDAM 330 and the lantern VDMA 341 as describe at chapter 2.2, and place the lantern 341 on the side motor flange keeping the two extraction niches horizontally towards the pump assembler.

Thoroughly clean every pump part with suitable tools and liquids compatible with the pump and elastomers materials. Wash externally the ball bearings, in proper conditions, with a suitable degreaser, dry them and afterwards oil them.

Insert the 4 screws T.E.F. VDMA 906 on the motor flange VDMA 801 (for TRMX 257) or on the bearing frame flange VDMA 330 (for TRVX 257) keeping a room of about 13 mm between the screws and the flange.

Apply pressure and install the stationary part of mechanical seal VDMA 433.2 inside the impeller cover VDMA 235 after lubricating the O-Ring and its seat with compatible liquid. Centre the eventual locating pin in case of long tail mechanical seal.

Install the rear body VDMA 235 on the motor flange VDMA 801 (for TRMX 257) or on the bearing frame flange VDMA 330 (for TRVX 257) and position it 45° on the right to fit the two pins VDMA 562 by centering the below register.

Then rotate counterclockwise the rear body VDMA 235 until it fits in the screws T.E.F. VDMA 906. Straight afterwards tighten the screws to secure everything.

Lubricate the shaft VDMA 210 and the elastomer of the mechanical seal rotating part VDMA 433.2. Slide the seal on the shaft taking care not to damage the elastomer: a special Ø24 mm fitting tool may be used to help this procedure.

If the mechanical seal is not of the type turning both clockwise and counterclockwise it must have a clockwise rotation or in any case it must be a standardized one.

Insert the key VDMA 940.1 of the impeller VDMA 230 in the shaft. Then insert the impeller, the safety unlocking washer VDMA 554.L and tighten the nut VDMA 920.

Check that the top of the impeller VDMA 230 is 0.10 - 0.15 mm lower than the supporting base of the suction/discharge plate VDMA 137 (see fig. 2): if not, loosen the 4 screws T.E.F. VDMA 906 until their heads lift the impeller cover VDMA 235. Now put some shims (in order to recover the required height) beneath the impeller cover supports and tighten again the 4 screws T.E.F. VDMA 906 (see fig. 3).

Insert the pins VDMA 562 in their seats, lay a strip of glue type Superbond 529 on the cover border of the impeller cover VDMA 235 and, referring to the reference pins VDMA 562, lay over that the suction/discharge plate VDMA 137 with the Teflon flapper VDMA 400.9 upwards.

Lay a strip of glue type Superbond 529 on the cover border of the suction/discharge casing VDMA 101. The glue must be also placed inside the 2 pins diameter and on the inner shaped tops. Then, referring to the reference pins VDMA 562, lay the suction/discharge casing VDMA 101 over the suction/discharge plate VDMA 137.

Tighten the four screws T.C.E.I. VDMA 914 (and the respective washers VDMA 554.5) with a torque of 2 kgm.

Check the free rotation of the pump rotor by inserting a temporary screw on the motor shaft VDMA 801 (for TRMX 257) at fan side or, before assembly the pump with the motor, on the shaft VDMA 210 inside the bearing frame VDMA 330 (for TRVX 257).

To verify the correct assembly and the perfect pump hydraulic tightness, wait about 2 hours (to let the glue dry) and carry out a static test under a maximum pressure of 3 bar.

Fig. 1 - Typical mechanical seal drawing on pumps type TRMX 257 and TRVX 257

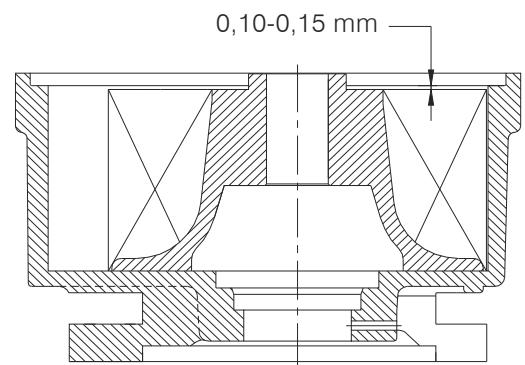
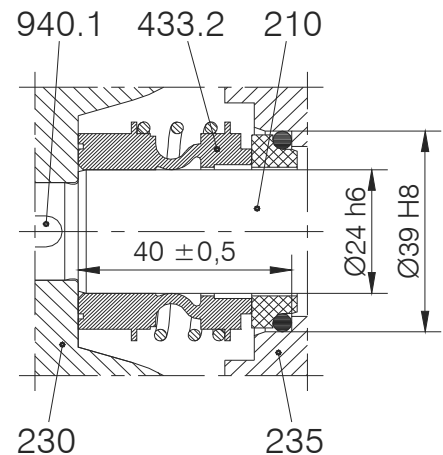

Fig. 2

2.2 – BEARING FRAME AND LANTERN ASSEMBLY OF PUMP TYPE "TRVX 257"

(See tab.1 for ball bearing dimensions).

Place in a vise the shaft VDMA 210 with the threaded part turned to the top and, after having heated up to approximately 80°C, place over the shaft 1 of the 2 ball bearing VDMA 320 and then lock it with its circlip VDMA 932. Insert the shaft with the ball bearing in the support VDMA 330 from pumps side, assemble the bearing cover VDMA 360.1 and lock with the three screws T.C.E.I VDMA 914.2 and locate the seal V-Ring VDMA 411 having care of the proper leap preload. Hold on the threaded shaft side the support VDMA 330 and. After having heated up to approximately 80°C, insert the second ball bearing VDMA 320 over the shaft, locate the wafer ring VDMA 935 and lock all parts pushing the circlip VDMA 932.3 in its seat. Insert the key VDMA 940 on shaft and, if foreseen for coupled pump, the half coupling VDMA 861.1 pump side over the shaft and lock the grub screw sealing it with SSuperbond 525. Assemble lantern VDMA 341 and lock it with the 4 screws T.E.F. VDMA 906, positioning the the draing hole on the same side of hole provided for the support foot. Insert the protection net VDMA 685 inside the lantern, locating it in way to live open one of the inspection openings to check the gap between the half couplings. Fix the support foot VDMA 183 by means of the T.E. screw VDMA 901.2 directed toward the motor.

Tab. 1 -Ball bearings type and size on pump type TRVX 257

BALL BEARINGS MODEL	
NON-DRIVE END	DRIVE END
N° 1 6007-2Z (35x62x14)	N° 1 6007-2Z (35x62x14)

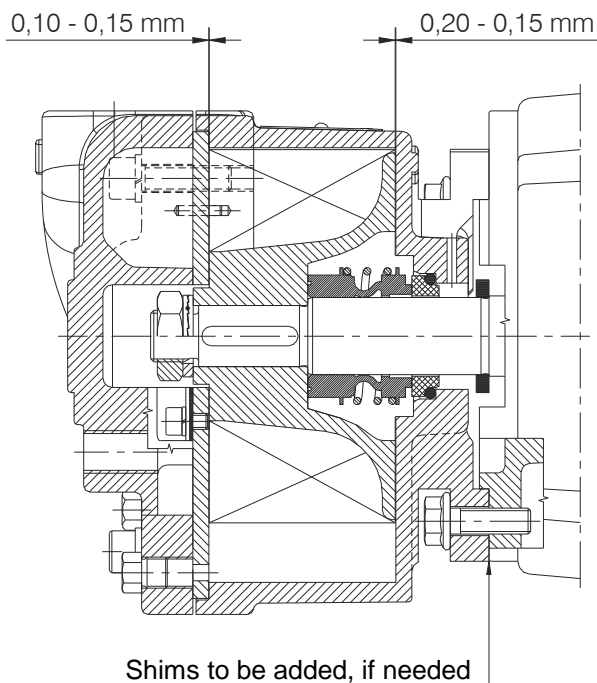

Fig. 3

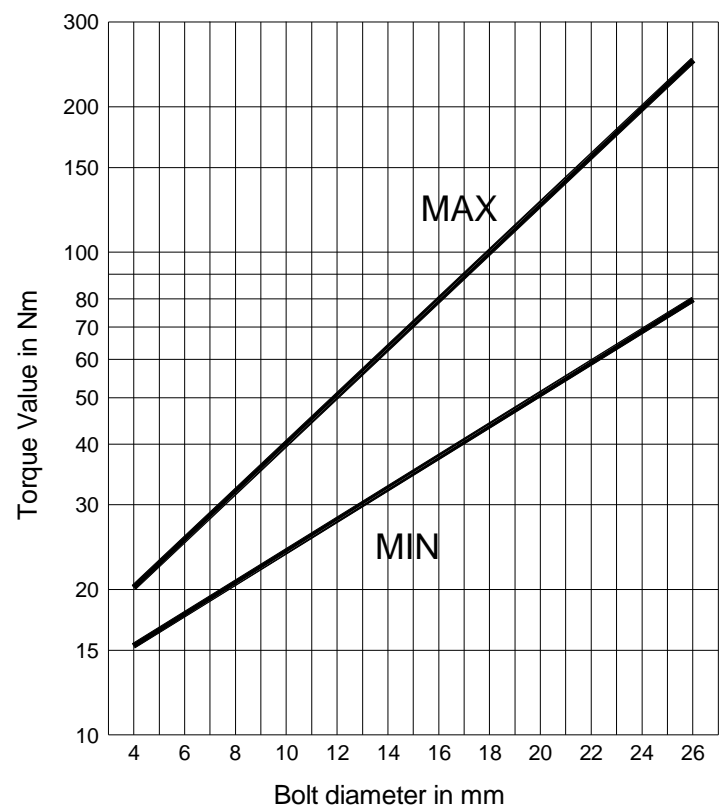

Fig. 4 - TORQUE VALUES FOR BOLTS AND NUTS OF VARIOUS DIAMETERS

2.3 – E-MOTOR ASSEMBLY OF PUMP TYPE "TRVX 257"

Assembly the half coupling VDMA 861.2 including the elastic dowel on the motor shaft, therefore couple the motor on lantern and lock it with the 4 screws T.E.F. VDMA 906, locating it in a way that the plane below the motor is the same as the plane of the support foot.

Check, trough one of the inspection openings, that the gap between the half couplings is 2 mm and then lock the grub screw of the motor side half coupling VDMA 861.2 and seal it with liquid sealant Superbond 525. Compress manually and simultaneously rotate the protection net VDMA 685, locating it in a way to close the lantern inspection openings.

3 - RECOMMENDED SPARE PARTS

When ordering the pump it is good practice to also order the necessary spare parts, especially when there are no stand-by pumps in the installation.

This will minimize unnecessary down times in the event of pump failures or routine maintenance.

It is therefore, recommended to stock the following spare parts for each pump size:

Pump series "TRMX 257"

- 1 Impeller
- 1 Mechanical seal
- 1 Electric motor
- 1 Gasket compound

Pump series "TRVX 257"

- 1 Impeller
- 1 Shaft assembly
- 2 Ball bearings
- 1 Mechanical seal
- 1 Seal V-Ring
- 1 Gasket compound
- 1 Set of coupling elastic dowels

For better parts management, the VDMA 24296 standards suggest to stock the number of parts as a function of the number of pumps being used in the plant.

On the pump nameplate are printed the pump model, year of manufacture and pump serial number. When ordering spare parts always refer to this information.

Pump type, parts item number (VDMA) and description, as per the parts list on chapter 4 and pump sectional drawings on chapter 5, are useful information that helps to supply and ensure correct spare parts for your pump.

We recommend the use of original parts: in case of deviation, POMPETRAVAINI declines any responsibility for damages that may be derived from the use of non original spare parts.

4 - PARTS LIST

VDMA NO	DESCRIPTION
101	Suction/discharge casing
137	Suction/discharge plate
180.5	Valve plate
183	Support foot
210	Shaft
230	Impeller
235	Impeller cover
320	Single row ball bearing
330	Bearing frame
341	Lantern
360.1	Bearing cover
400.9	Flapper
411	Seal V-Ring
433.2	Mechanical seal
507	Thrower

VDMA NO	DESCRIPTION
554...	Elastic washer
554.L	Lock washer
562	Locating pin
685	Protection net
801	Electric motor
861...	Half coupling
901...	Screw T.E.
903...	Plug
906	Screw
914...	Screw
920	Impeller nut
932...	Circlip
935	Elastic ring
940.1	Key
Z	Liquid supply inlet

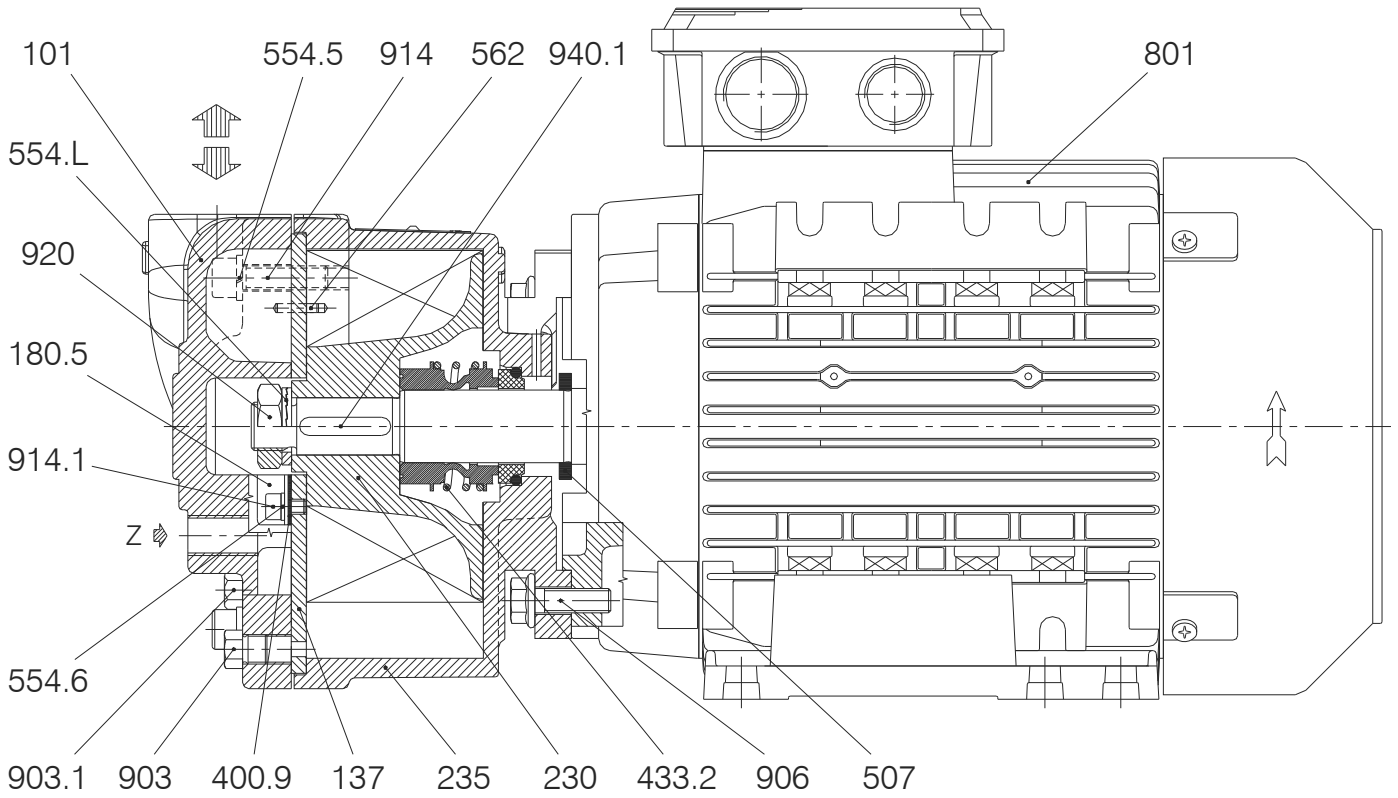

TRMX 257 (Motor frame: 90)

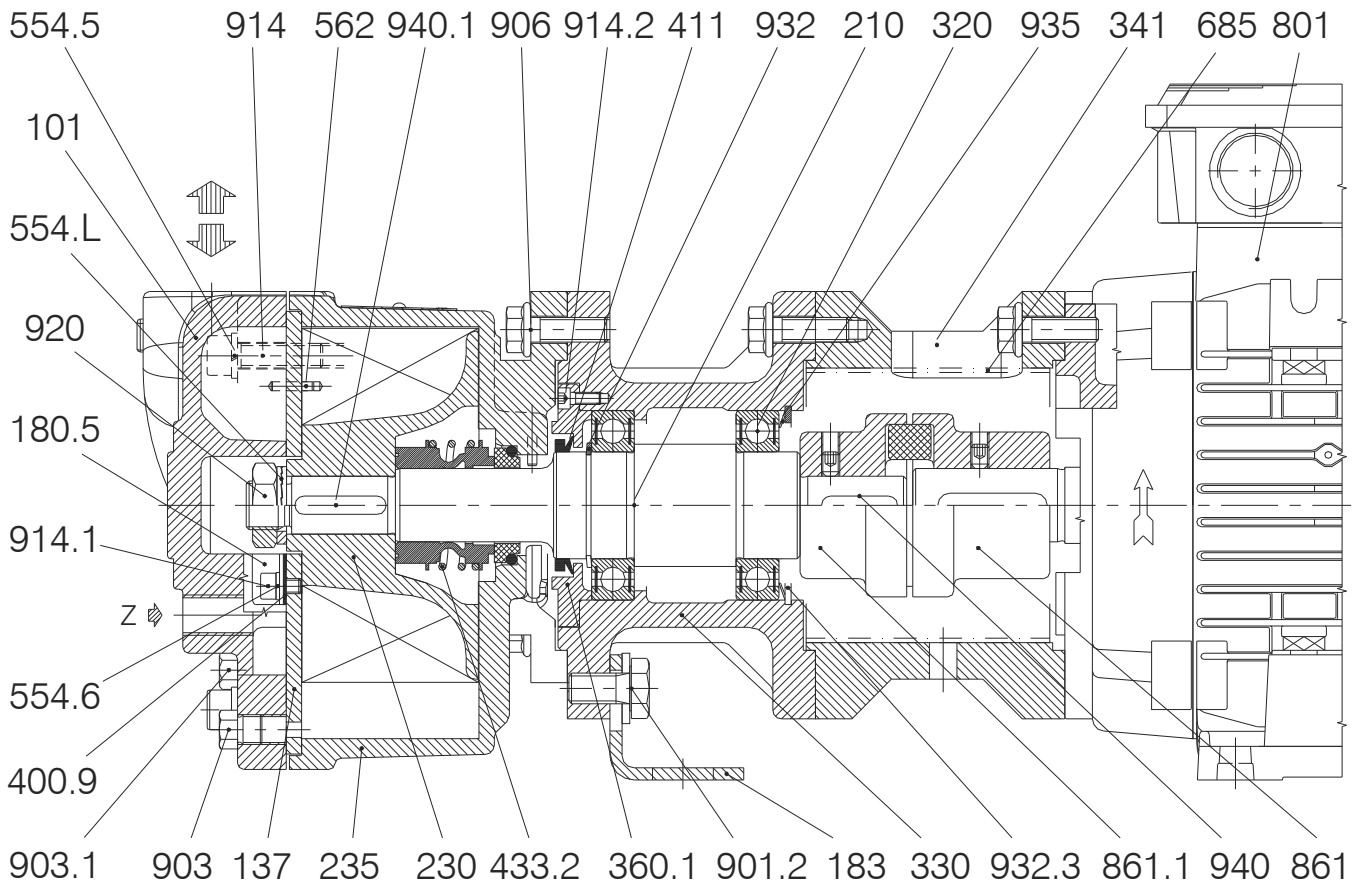

TRVX 257 (Motor frame: 90)

NOTES

PUMP model	Serial Number	Computer Number	Year of manuf.
---------------------	------------------------	--------------------------	-------------------------

GAS handled	Capacitym ³ /h	Suction Pressurembar	Discharge Press.mbar	Temperature°C
<input type="checkbox"/> Lethal <input type="checkbox"/> Toxic <input type="checkbox"/> Noxious <input type="checkbox"/> Corrosive <input type="checkbox"/> Malodorous <input type="checkbox"/>				

Service LIQUID	Capacitym ³ /h	Temperature°C
-------------------------	------------------------------------	------------------------

TOTAL WEIGHTKGS.

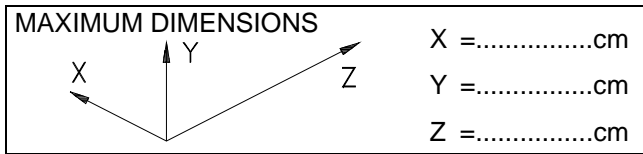

NOISE (measured at 1 m)
Pressure =.....dB(A)
Power =.....dB(A)

INSTALLATION

Inside Outside

Explosive area

SERVICE

Continuous Intermittent

.....

MOTOR type / Frame	No Poles	No RevolutionsRPM	Absorbed powerAmp	Installed powerkW /HP
FrequencyHz	SupplyVolt	Enclosure IP.....	Insulation class	Absorbed powerkW /HP

COMMENTS

NA5.SM.MVX2.GB00 / PRINTED IN ITALY
Smontaggio TRMX-TRVX 257 Inglese

Continuing research of POMPETRAVAINI results in product improvements: therefore any specifications may be subject to change without notice.

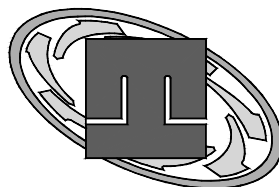
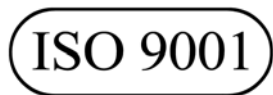

pompetravaini S.p.A.
20022 CASTANO PRIMO (Milano) ITALY
Via per Turbigo, 44 – Zona Industriale
Tel. 0331 889000 – Fax 0331 889090
www.pompetravaini.it