

Pump construction

Vertical construction adopts V1 IEC motor standard.
Base flange designed on customer specification.

Connections:

Threaded BSP (GAS) & NPT.

Flange rating per DIN Norms Class PN16 - 40

Flange rating per ANSI B16.5 Class 150 and 300 lbs

Performance curves

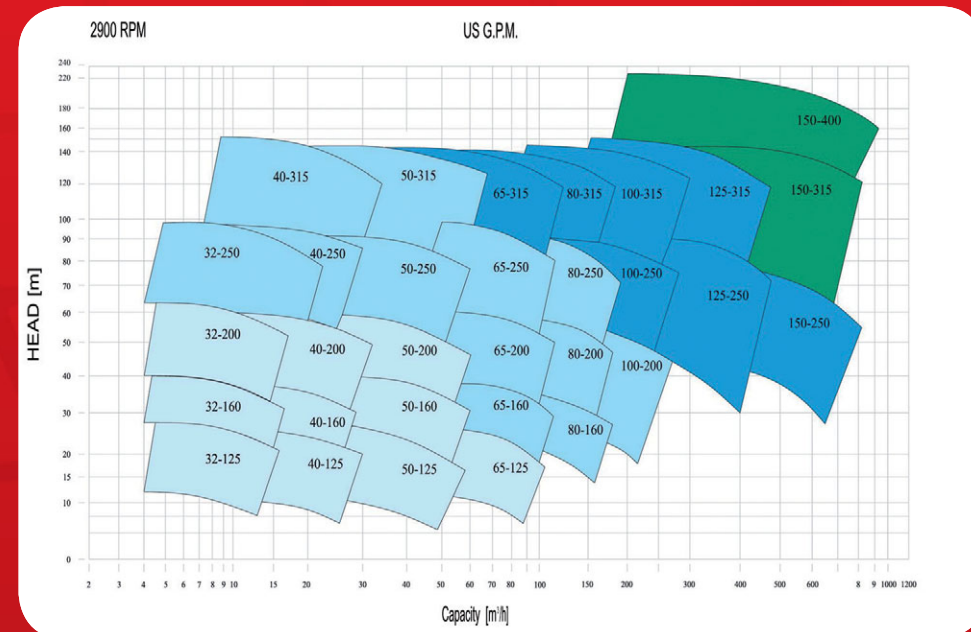

Operating Limits

- Max viscosity: 200 cSt
- Max system pressure: 16bar (standard)
150bar (HP Version)
Higher pressure version available on request.
- Flow up: to 500 mc/h
- Head up: to 120m
- Temperature range: from -185 °F (-120 °C)
to +482 °F (+250 °C)
- Electric motors: from 1,5kW
up to 500kW
- Maximum lenght: 7 meters

VERTICAL, SEALLESS CENTRIFUGAL PUMP WITH PERMANENT MAGNET DRIVE SYSTEM NO MECHANICAL SEAL



CNV MAG-M

Manufactured by:



A unit of
Mischiatti
GROUP

M PUMPS s.r.l. - Via dell'Artigianato, 120
45015 Corbola (Ro) - Italy - www.mpumps.it
Tel. +39 0426 346304 - Fax +39 0426 349126

For more information please contact:



CNV MAG-M Series

The separation of liquid chamber/atmosphere by means of an isolation shell is the best solution to pump aggressive, explosive and toxic liquids, hydrocarbons, heat transfer liquids and liquids difficult to seal.

The hermetic sealless is the best solution for the chemical, pharmaceutical and petrochemical industry.

A wide range of pumps covers the different performances.
Modular construction allows lenghts up to 7 meters.



PUMP DETAILS

Epoxy primer and polyacrylic enamel water-based painting for the best quality resistance linked to the environmental respect.

RWP QUICK CHANGE CARTRIDGE KIT to guarantee an easy and fast maintenance.



Particular design of the hydraulic, with self balancing impeller to improve the the wear ring life.



CF8M or WCB Pump Casing & Impeller High quality casting components.

Other materials:
 - Hastelloy® C276
 - Incoloy® 825
 - Duplex
 - Others available on request.

The sealing system with flat gaskets prevents product from leaking in the atmosphere – different materials available:

- Asbestos free (standard)
- PTFE
- Graphoil
- VITON®
- GYLON®

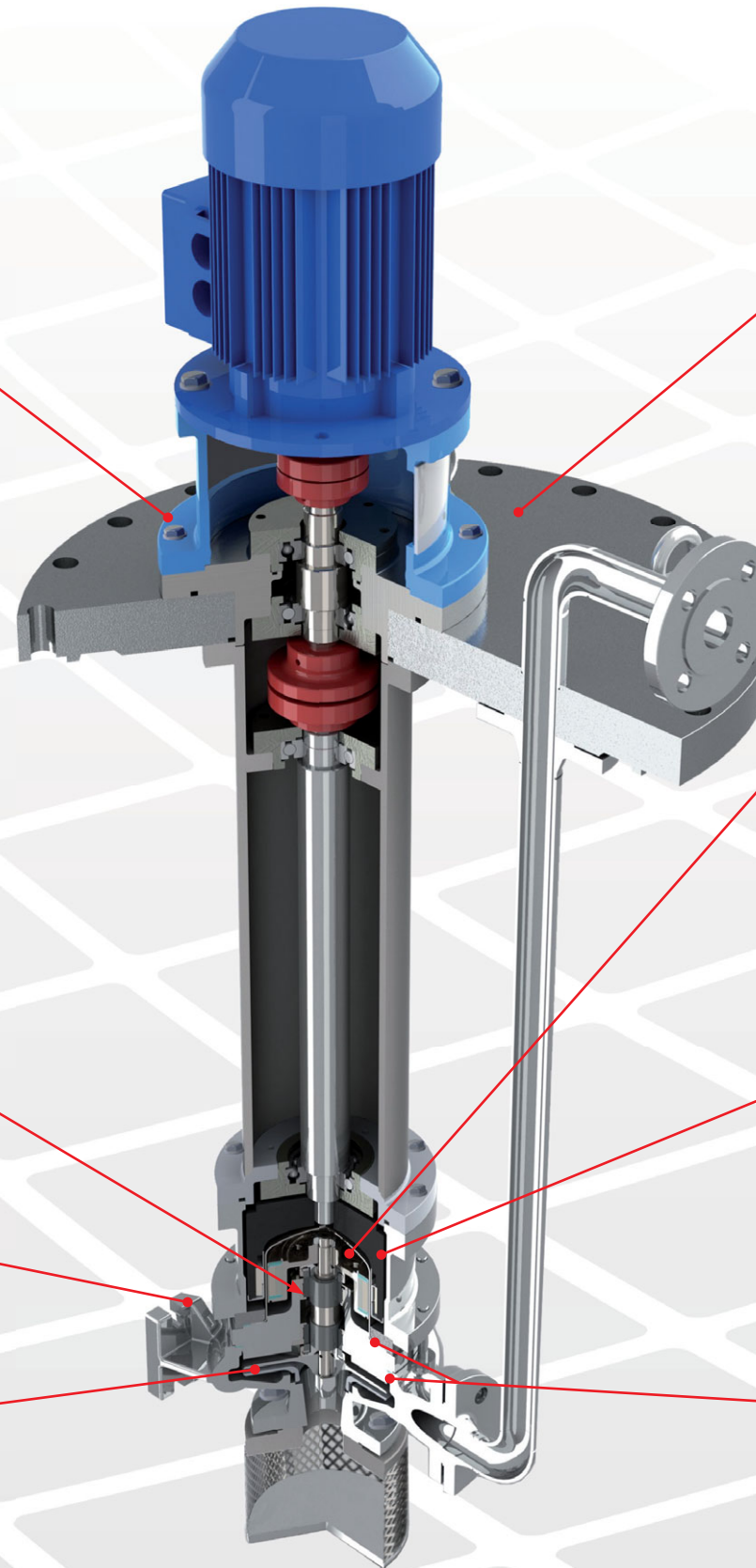

Custom design base plate, stainless steel.

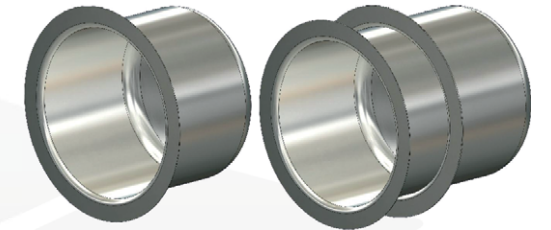

The rear shell is made of one single piece, no welding, ellipsoidal profile that has been studied to withstand higher pressures than the traditional one.

Available two versions, AISI 316 the standard construction, and Hastelloy® C276 for high pressure version - providing a safe and efficient solution – system pressure max 150bar.

Titanium Alloy is an upgrade when higher pressure ratings and increased efficiency are required.

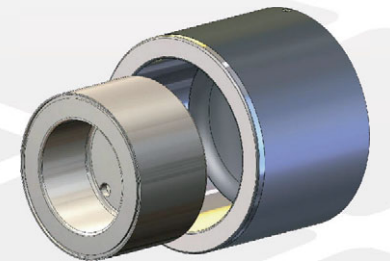

High power synchronous magnetic coupling designed by our Technical Office and with rare earth magnetic elements mechanically locked.

The high performance magnets can operate at liquid temperature of up to 662 °F (350 °C) without external cooling.

Field assembling of the product lubricated bearing arrangement does not require special tools.

Bearing materials are available in four different types to provide the best solution for each application: Silicon Carbide (SSIC), Tungsten Carbide (WC), Special Carbon to allow a dry running situation and PTFEC/G for any applications where the Special Carbon cannot be used.

The adoption of elastic rings reduces the sleeve bearing loads and the thrust bearing loads to the minimum, to guarantee many years of maintenance-free operation.